



Montana Field Guide - Manufactured Housing



Standard Work Specifications

Field Guide for

Manufactured Housing

created by

State of Montana - DPHHS



2 Health and Safety

2.01 Safe Work Practices

2.0100 Safe Work Practices

2.0100.2 Global Worker Safety

2.0100.2a	Prevention through design	22
2.0100.2b	Hand protection	23
2.0100.2c	Respiratory protection	25
2.0100.2d	Personal protective equipment (PPE)	27
2.0100.2e	Confined space safety	29
2.0100.2f	Power tool safety	32
2.0100.2g	Chemical safety	34
2.0100.2h	Ergonomic safety	35
2.0100.2i	Hand tool safety	36
2.0100.2j	Slips, trips, and falls	37
2.0100.2k	Heat and thermal stress	38
2.0100.2l	Fire safety	39
2.0100.2m	Crawl space safety	41

2.0103 Air Sealing

2.0103.1 Air Sealing Worker Safety

2.0103.1a	Worker safety	42
-----------	---------------------	----

2.0104 Insulation

2.0104.1 Insulation Worker Safety

2.0104.1a	Worker safety	43
2.0104.1b	Vermiculite	44
2.0104.1c	Respiratory protection	46
2.0104.1d	Lead paint assessment	48

2.0105 Heating and Cooling Equipment

2.0105.3 Combustion Worker Safety

2.0105.3a	Worker safety	50
-----------	---------------------	----

2.0105.4 Heating and Cooling Worker Safety

2.0105.4a	Worker safety	51
2.0105.4b	Mercury	52
2.0105.4c	Asbestos	53
2.0105.4d	Personal protective equipment (PPE)	54
2.0105.4e	Combustible gas detection	56
2.0105.4f	Carbon monoxide (CO)	58
2.0105.4g	Sealant	60
2.0105.4h	Safety devices	61

2.0106 Ventilation Equipment

2.0106.1 Ventilation Worker Safety

2.0106.1a	Worker safety	62
-----------	---------------------	----

2.0110 Material Safety

2.0110.1 Material Selection, Labeling, and Material Safety Data Sheets (MSDSs)

2.0110.1a Material selection 63

2.0110.1b Material labels 64

2.0110.1c Material Safety Data Sheets (MSDSs) 65

2.0111 Basements and Crawl Spaces

2.0111.5 Prework Qualifications (Home Installation)

2.0111.5a Installation deficiencies 66

2.0111.5b Stabilization 68

2.02 Combustion Safety

2.0201 Combustion Safety Testing-General

2.0201.2 Combustion Safety

2.0201.2a Outside combustion makeup air 69

2.0201.2b New appliances 71

2.0201.2c CO detection and warning equipment 73

2.0201.2d Gas ovens 74

2.0201.2e Gas range burners 75

2.0201.2f Solid fuel-burning appliances 77

2.0201.3 Combustion Appliance Zone (CAZ) Testing

2.0201.3a Assessment 79

2.0201.3b Fuel leak detection 81

2.0201.3c Venting 83

2.0201.3d Base pressure test 85

2.0201.3e Depressurization test 86

2.0201.3f Spillage test 88

2.0201.3g Carbon monoxide (CO) test in appliance vent 89

2.0201.3h Final test out 91

2.0202 Unvented Space Heaters

2.0202.1 Unvented Space Heaters: Propane, Natural Gas, and Kerosene Heaters

2.0202.1a Removal 93

2.0202.1b Occupant education 95

2.0203 Vented Gas Appliances

2.0203.4 Combustion Air for Natural Draft Appliances

2.0203.4a Required combustion air 97

2.0203.4b Additional combustion air (if action is required) 100

2.0203.4c Spillage testing 103

2.0203.4d Occupant health and safety 105

2.0203.4e Occupant education 107

2.0203.5 Combustion Flue Gas—Orphaned Water Heaters

2.0203.5a Spillage testing 109

2.0203.5b Retesting spillage 110

2.0203.5c Required combustion air 112

2.0203.5d Additional combustion air (if action is required) 115

Table of Contents

2.0203.5e Occupant health and safety..... 117

2.0203.5f Occupant education 119

2.0203.6 Draft Regulation—Category I Appliance

2.0203.6a Assessment..... 121

2.0203.6b Installation (if action is required)..... 122

2.0203.6c Retesting spillage 123

2.0203.6d Occupant health and safety..... 124

2.0203.6e Occupant education 126

2.0204 Isolation

2.0204.1 Isolating Combustion Water Heater Closet

2.0204.1a Work assessment..... 128

2.0204.1b Air seal closet 129

2.0204.1c Materials 130

2.0204.1d Post-work testing/verification..... 131

2.0299 Additional Resources

2.0299.1 Combustion Appliance Depressurization Limits Table

2.0299.1a Atmospheric water heater only (Category I, natural draft), open-combustion
appliances 133

2.0299.1b Atmospheric water heater (Category I, natural draft) and atmospheric furnace (Category I,
natural draft), common-vented, open-combustion applianc 134

2.0299.1c Gas furnace or boiler, Category I or Category I fan-assisted, open-combustion
appliances 136

2.0299.1d Oil or gas unit with power burner, low- or high-static pressure burner, open combustion
appliances 138

2.0299.1e Closed, controlled wood-burning appliances..... 139

2.0299.1f Induced-draft appliances (fan at point of exit at wall), Category I with induced draft, open-
combustion appliances 140

2.0299.1g Pellet stoves with exhaust fan and sealed vent..... 141

2.0299.1h Gas appliances, Category III vented through the wall, forced draft, open-combustion
appliances 142

2.0299.1i Direct-vent, sealed combustion appliances with forced draft 144

2.03 Safety Devices

2.0301 Combustion Safety Devices

2.0301.1 Smoke Alarm

2.0301.1a Smoke alarm (hardwired) 146

2.0301.1b Smoke alarm (battery operated)..... 147

2.0301.2 Carbon Monoxide Alarm or Monitor

2.0301.2a CO detection and warning equipment (hardwired) 149

2.0301.2b CO detection and warning equipment (battery operated) 151

2.04 Moisture

2.0401 Air Sealing

2.0401.1 Air Sealing Moisture Precautions

2.0401.1a	Moisture precautions for attics	152
2.0401.1b	Moisture precautions for crawl spaces	153
2.0401.1c	Moisture precautions for the living space	154
2.0401.1d	Moisture precautions for exterior water	155

2.0402 Drainage

2.0402.2 Site Improvements/Conditions (e.g., Leveling, Drainage, Vegetation)

2.0402.2a	Work assessment	156
2.0402.2b	Corrective action	157
2.0402.2c	Occupant education	158

2.0403 Vapor Barriers

2.0403.4 Pier and Skirting Foundations—Ground Moisture Barriers

2.0403.4a	Coverage	159
2.0403.4b	Material specification	161
2.0403.4c	Overlap seams	163
2.0403.4d	Fastening	165

2.0404 Space Conditioning

2.0404.1 Stand-Alone Dehumidifiers

2.0404.1a	Selection	166
2.0404.1b	Installation	167
2.0404.1c	Decommissioning	169

2.0404.2 Crawl Spaces—Preliminary Dehumidification

2.0404.2a	Close vents	170
2.0404.2b	Drying	172
2.0404.2c	Drying time	173

2.0404.4 Basements—Dehumidification

2.0404.4a	Dehumidifier	174
2.0404.4b	Dehumidification for divided spaces	175
2.0404.4c	Relative humidity	176
2.0404.4d	Condensing surfaces (e.g., cold water pipes)	177
2.0404.4e	Dehumidification (option for dry climates and heating- dominated climates seasonally)	178
2.0404.4f	Occupant education	179

2.05 Radon

2.0501 Air Sealing

2.0501.4 Pier and Skirting Foundation—Venting

2.0501.4a	Venting	180
2.0501.4b	Occupant education	181

2.06 Electrical

2.0602 Electric Hazards

2.0602.1 Static Electric Shock

2.0602.1a Rigid fill tube 183

2.0602.1b Metal coupler grounding 185

2.0602.2 House Current Electric Hazard

2.0602.2a Metal skin and frame grounding 187

2.0602.2b Metal fill tube grounding 188

2.0602.2c Electrical tool safety 190

2.0602.2d Aluminum wiring 192

3 Air Sealing

3.10 Attics

3.1001 Penetrations and Chases

3.1001.4 General Penetrations (Electrical, HVAC, Plumbing, Vent Termination, Recessed Lighting)

3.1001.4a Work assessment 194

3.1001.4b Air sealing penetrations 195

3.1001.4c Sealant selection 197

3.1001.4d Ceiling hole repair 199

3.1001.4e Materials 202

3.1001.4f High temperature application 203

3.11 Walls

3.1101 Manufactured Housing Walls

3.1101.1 Exterior Holes and Penetrations

3.1101.1a Work assessment 205

3.1101.1b Materials 206

3.1101.1c Exterior wall air sealing 208

3.1101.2 Interior Holes and Penetrations

3.1101.2a Work assessment 211

3.1101.2b Interior wall air sealing 212

3.1101.2c Materials 214

3.1101.3 Holes, Penetrations, and Marriage Line

3.1101.3a Work assessment 215

3.1101.3b Marriage wall air sealing of holes and penetrations 216

3.1101.3c Marriage line air sealing 219

3.1101.3d Materials 222

3.12 Windows and Doors

3.1201 Maintenance, Repair, and Sealing

3.1201.5 Manufactured Housing Windows and Doors

3.1201.5a Work assessment 223

3.1201.5b Lead paint assessment 224

3.1201.5c Operable windows and doors 226

Table of Contents

3.1201.5d	Air infiltration.....	228
3.1201.5e	Water infiltration.....	230
3.1201.5f	Materials.....	231
3.1201.5g	Quality assurance.....	232
3.1201.5h	Occupant education and maintenance.....	233
3.1201.6	Interior Storm Windows	
3.1201.6a	Work assessment.....	234
3.1201.6b	Fixed storm window.....	235
3.1201.6c	Installing operable storm window.....	236
3.1201.6d	Health and safety.....	238
3.1201.6e	Occupant education.....	239
3.1202	Repairing/Replacing Cracked and Broken Glass	
3.1202.3	Replacing Damaged Window Glass in Manufactured Housing	
3.1202.3a	Work assessment.....	240
3.1202.3b	Lead paint assessment.....	241
3.1202.3c	Broken glass removal.....	243
3.1202.3d	Opening preparation.....	245
3.1202.3e	New glass installation.....	247
3.1203	Replacement	
3.1203.3	Replacement of Manufactured Housing Windows and Doors	
3.1203.3a	Work assessment.....	249
3.1203.3b	Lead paint assessment.....	250
3.1203.3c	Window or door selection.....	252
3.1203.3d	Rough opening preparation.....	253
3.1203.3e	Window and door installation.....	254
3.1203.3f	Safety.....	256
3.1203.3g	Maintenance and occupant education.....	257
3.13	Floors	
3.1301	Penetrations	
3.1301.1	Electrical, HVAC, Plumbing, Gas, Dryer Vent, and General Penetrations Through Bottom Board	
3.1301.1a	Work assessment.....	258
3.1301.1b	Soft bottom board repair.....	259
3.1301.1c	Hard bottom board repair.....	260
3.1301.1d	Bottom board penetrations.....	261
3.1301.1e	Materials.....	264
3.1301.2	Electrical, HVAC, Plumbing, Gas, Dryer Vent, and General Penetrations Through Flooring	
3.1301.2a	Work assessment.....	265
3.1301.2b	Floor air sealing (decking, subfloor, floor decking).....	266
3.1301.2c	Sealant selection.....	268
3.1301.2d	Floor repair.....	270
3.1301.2e	Structural materials.....	273
3.1301.2f	High temperature application.....	274

3.1302 Floor Framing

3.1302.1 Floor Framing—Bay Window

3.1302.1a Work assessment 276
 3.1302.1b Lead paint assessment 277
 3.1302.1c Air infiltration 279
 3.1302.1d Water infiltration 280
 3.1302.1e Materials 281

3.14 Basements and Crawl Spaces

3.1488 Special Considerations

3.1488.2 Skirting Manufactured Homes

3.1488.2a Work assessment 282
 3.1488.2b Repair and installation 283
 3.1488.2c Venting 284
 3.1488.2d Insulated skirting 285
 3.1488.2e Flashing 286
 3.1488.2f Materials 287
 3.1488.2g Fasteners 288
 3.1488.2h Structural 289
 3.1488.2i Skirting stiffener/high wind support 290
 3.1488.2j Occupant education 291

3.16 Ducts

3.1601 Duct Preparation

3.1601.2 Duct Preparation for SPF Application

3.1601.2a Inspection 292
 3.1601.2b Repair 293

3.1601.4 Support for Horizontal, Suspended Ducts

3.1601.4a Support (applies to all duct types) 294

3.1601.5 Preparation and Mechanical Fastening

3.1601.5a Preparation 295
 3.1601.5b Metal to metal 297
 3.1601.5c Flex to metal 299
 3.1601.5d Duct board to duct board 301
 3.1601.5e Duct board to flexible duct 302
 3.1601.5f Duct board plenum to air handler cabinet 305
 3.1601.5g Boot to wood 306
 3.1601.5h Boot to gypsum 308
 3.1601.5i Duct board to flex 311

3.1602 Duct Sealing

3.1602.2 Duct Spray Polyurethane Foam (SPF) Installation

3.1602.2a Installation 313

3.1602.3 Proprietary Spray Application

3.1602.3a Internal or external application 314

3.1602.8 Supply Plenum (Furnace to Trunk Duct Connection) in Both Upflow and Downflow Air Handler Configurations	
3.1602.8a Work assessment.....	315
3.1602.8b Preparation.....	316
3.1602.8c Plenum rebuild or repair.....	318
3.1602.8d Repair work access.....	320
3.1602.8e Safety testing.....	323
3.1602.8f Performance testing.....	325
3.1602.9 Crossover Ducts	
3.1602.9a Work assessment.....	327
3.1602.9b Flexible crossover duct connections.....	328
3.1602.9c Support.....	331
3.1602.9d Through-the-rim crossover duct.....	332
3.1602.9e Repair work access for through-the-rim crossover.....	333
3.1602.9f Attic crossover.....	334
3.1602.9g Combustion Appliance Zone (CAZ) testing.....	335
3.1602.9h Performance testing.....	336
3.1602.10 Hard and Flex Branch Ducts	
3.1602.10a Work assessment.....	338
3.1602.10b Reduce excess flex duct length.....	339
3.1602.10c Duct connection repairs.....	340
3.1602.10d Repair work access.....	342
3.1602.10e Combustion Appliance Zone (CAZ) testing.....	345
3.1602.10f Performance testing.....	346
3.1602.11 Air Sealing System	
3.1602.11a New component to new component sealant selection.....	348
3.1602.11b New component to existing component.....	351
3.1602.11c Existing component to existing component.....	354
3.1602.11d Performance testing.....	357
3.1602.12 Air Sealing System Components	
3.1602.12a Duct boot to interior surface.....	359
3.1602.12b Air handler cabinet outside conditioned space.....	361
3.1602.12c Performance testing.....	363
3.1602.13 Return—Framed Platform	
3.1602.13a Preparation.....	365
3.1602.13b Infill and backing.....	366
3.1602.13c Sealant selection.....	368
3.17 Additions	
3.1701 Attached Additions	
3.1701.1 Holes, Penetrations, and Connection Seam	
3.1701.1a Work assessment.....	369
3.1701.1b Hole, seam, line, and penetration sealing.....	370
3.1701.1c Materials.....	371
3.1701.1d Addition exterior wall air sealing.....	372
3.1701.1e Addition interior wall air sealing.....	373

3.1701.1f	Addition floor air sealing (decking, subfloor, floor decking)	374
3.1701.1g	Sealant selection	375
3.1701.1h	Floor repair	377
3.1701.1i	Structural materials	380
3.1701.1j	Ceiling hole repair	381
3.1701.1k	High temperature application	384

4 Insulation

4.10 Attics

4.1002 Above Roof Deck Insulation

4.1002.1 Above Roof Deck Insulation: Preparation

4.1002.1b	Roof covering replacement	386
-----------	---------------------------	-----

4.1002.2 Above Deck Roof Deck Insulation: Installation

4.1002.2a	Sealing	387
4.1002.2b	Installation	388
4.1002.2c	Occupant education	389

4.1003 Attic Ceilings

4.1003.8 Installing Fiberglass Blown Insulation for Flat, Bowed, or Vaulted Ceilings (via Roof Side Lift)

4.1003.8a	Attic, ceiling, and roof verification	390
4.1003.8b	Attic access	393
4.1003.8c	Blowing machine set up	396
4.1003.8d	Fiberglass blown insulation installation	398
4.1003.8e	Roof reattachment	401
4.1003.8f	Verification of details	403
4.1003.8g	Onsite documentation	404

4.1003.9 Installing Fiberglass Blown Insulation for Flat, Bowed, or Vaulted Ceilings (via Exterior Access from Top of Roof)

4.1003.9a	Attic, ceiling, and roof verification	405
4.1003.9b	Attic access	408
4.1003.9c	Blowing machine set up	411
4.1003.9d	Fiberglass blown insulation installation	413
4.1003.9e	Patching and sealing openings	416
4.1003.9f	Verification of details	419
4.1003.9g	Onsite documentation	420

4.1003.10 Installing Fiberglass Blown Insulation for Flat, Bowed, or Vaulted Ceilings (via Interior Access Through the Ceiling)

4.1003.10a	Attic, ceiling, and roof verification	421
4.1003.10b	Construction prep	424
4.1003.10c	Attic access	425
4.1003.10d	Blowing machine set up	427
4.1003.10e	Fiberglass blown insulation installation	429
4.1003.10f	Patching and sealing holes	432
4.1003.10g	Verification of details	433
4.1003.10h	Onsite Documentation	434

4.1003.11 Installing Fiberglass Blown Insulation in Roof-Over Constructions	
4.1003.11a Roof-over overview	435
4.1003.11b Onsite documentation	436
4.1088 Special Considerations	
4.1088.6 Installing Insulation at Flat and Cathedral Ceiling Transition Wall	
4.1088.6a Insulation installation verification	437
4.1088.6b Access attic	438
4.1088.6c Blowing	439
4.1088.6d Spray two-part foam	441
4.1088.6e Batt	442
4.1088.6f Patching and sealing access points	443
4.1088.6g Verification of details	444
4.1088.6h Onsite Documentation	445
4.11 Walls	
4.1101 Preparation	
4.1101.5 Exterior Wall Dense Packing	
4.1101.5a Preparation	446
4.1101.5b Exterior dense pack	447
4.1104 Manufactured Housing Wall Insulation	
4.1104.1 Stuffing Wall Cavities with Fiberglass Batts	
4.1104.1a Access wall cavities	448
4.1104.1b Exterior wall cavity inspection	450
4.1104.1c Fiberglass batt installation tool (stuffer)	453
4.1104.1d Fiberglass batt installation	455
4.1104.1e Sub-sheathing patch and repair	458
4.1104.1f Reattachment	459
4.1104.1g Onsite documentation	461
4.1104.2 Fiberglass Blown Insulation Installation (Lifting Siding)	
4.1104.2a Access wall cavities	462
4.1104.2b Exterior wall cavity inspection	463
4.1104.2c Blowing machine set up	464
4.1104.2d Fiberglass blown insulation installation	466
4.1104.2e Subsheathing patch and repair	467
4.1104.2f Reattachment	468
4.1104.2g Onsite documentation	469
4.1104.3 Fiberglass Blown Insulation Installation (via Penetrations Through or Behind the Siding)	
4.1104.3a Access wall cavities	470
4.1104.3b Exterior wall cavity inspection	471
4.1104.3c Blowing machine set up	472
4.1104.3d Fiberglass blown insulation installation	474
4.1104.3e Plug and seal holes	475
4.1104.3f Final wall assembly	476
4.1104.3g Onsite documentation	477

4.1104.4	Spray Foam Insulation Installation in Cavities above Doors and Windows	
4.1104.4a	Access wall cavities above doors and windows	478
4.1104.4b	Cavity inspection	479
4.1104.4c	Insulation installation	480
4.1104.4d	Final wall assembly	481
4.1104.4e	Onsite documentation	482
4.13	Floors	
4.1302	Manufactured Housing Belly Preparation	
4.1302.1	Prepare Belly Floor Cavity for Insulation	
4.1302.1a	Work assessment	483
4.1302.1b	Preparation	484
4.1303	Manufactured Housing Floor Cavity Insulation	
4.1303.1	Insulation of Floor Cavity with Blown Material	
4.1303.1a	R-value	485
4.1303.1b	Work assessment	486
4.1303.1c	Insulate floors	487
4.1303.1d	Materials	488
4.1303.1e	Occupant education	489
4.1303.2	Insulation of Floor Cavity with Batt Material	
4.1303.2a	R-value	491
4.1303.2b	Work assessment	492
4.1303.2c	Insulate floors	494
4.1303.2d	Materials	497
4.1303.2e	Occupant education	499
4.1303.3	Insulation of Floor Cavity with Spray Foam Material	
4.1303.3a	R-value	501
4.1303.3b	Work assessment	502
4.1303.3c	Preparation	503
4.1303.3d	Installation	504
4.1303.3e	Materials	505
4.1303.3f	Fire protection	506
4.1303.3g	Occupant education	507
4.14	Basements and Crawl Spaces	
4.1402	Basements and Crawl Space Walls	
4.1402.2	Basement Wall Insulation—No Groundwater Leakage	
4.1402.2a	R-value	509
4.1402.2b	Air barrier	510
4.1402.2c	Vapor permeability	512
4.1402.3	Basement Wall Insulation—Groundwater Leakage	
4.1402.3a	Drainage	515
4.1402.3b	Rough finish walls (e.g., rubble walls)	516
4.1402.3c	Thermal barrier, insulation	517
4.1402.3d	Location	518
4.1402.3e	Termite protection	519

Table of Contents

4.1402.3f	Insulation attachment	520
4.1402.3g	R-value	521
4.1402.3h	Sealing	522
4.1402.3i	Finish wall requirements.....	523
4.1402.3j	Onsite documentation	524
4.1488 Special Considerations		
4.1488.1 Climate Considerations for Insulating Water Lines Located Between Bottom Board and Ground		
4.1488.1a	Work assessment.....	525
4.1488.1b	Installation	526
4.1488.1c	Occupant education	529
4.16 Ducts		
4.1601 Insulating Ducts		
4.1601.3 Insulation and Vapor Barrier		
4.1601.3a	Ducts in unconditioned spaces (e.g., crawl space, attic, unconditioned basements).....	530
4.1601.3b	Ducts within floor assemblies	531
4.1601.3c	Exposed metal.....	532
4.1601.4 Insulating Flex Ducts		
4.1601.4a	Removal of existing flexible ducting	533
4.1601.4b	Selection of new flexible ducting	534
4.1601.4c	Sizing of new flex	535
4.1601.4d	Installation of flex.....	536
4.1601.4e	Interior liner attachment.....	538
4.1601.4f	Sealing of interior liner.....	539
4.1601.4g	Attachment of exterior liner	540
4.1601.4h	Sealing of all accessible ducts	542
4.1601.4i	Insulation of all fittings	543
4.1601.4j	Completeness of vapor barrier	544
4.1601.4k	Vermin proofing	545
4.1601.4l	CAZ testing.....	546
4.1601.5 Insulating Metal Ducts		
4.1601.5a	Selection of duct insulation material	547
4.1601.5b	Duct sealing.....	549
4.1601.5c	Attachment of duct insulation	551
4.1601.5d	Taping of the vapor barrier	552
4.1601.5e	Vermin proofing	553
4.99 Insulation—Additional Resources		
4.9901 Materials		
4.9901.1 General Information on Spray Polyurethane Foam (SPF)		
4.9901.1a	Low-Pressure SPF	555
4.9901.1b	High-Pressure SPF.....	556
4.9901.1c	Manufacturer Installation Instructions.....	557

5 Heating and Cooling

5.30 Forced Air

5.3001 Design

5.3001.3 Replace Return Air Systems that Incorporate Floor Cavity (Belly) and/or Attic as the Return Air Pathway

5.3001.3a	Close return air openings	558
5.3001.3b	Alternate return air system	559
5.3001.3c	Zone pressure test	560
5.3001.3d	Combustion Appliance Zone (CAZ) testing	561
5.3001.3e	Occupant education	562

5.3003 System Assessment and Maintenance

5.3003.1 Data Plate Verification

5.3003.1a	Data plate verification	563
-----------	-------------------------------	-----

5.3003.3 Evaluating Air Flow

5.3003.3a	Total air flow	564
5.3003.3b	External static pressure	565
5.3003.3c	Pressure	566
5.3003.3d	Pressure drop: filter	568
5.3003.3e	Balancing room flow: new ductwork	569
5.3003.3f	Supply wet bulb and dry bulb	570
5.3003.3g	Return wet bulb and dry bulb	571
5.3003.3h	Temperature rise: gas and oil furnaces only	572

5.3003.5 Refrigerant Line Inspection

5.3003.5a	Insulation	575
5.3003.5b	Ultraviolet (UV) protection of insulation	576
5.3003.5c	Sizing	577
5.3003.5d	Installation quality	578
5.3003.5e	Support	579

5.3003.6 Evaluating Sequence of Operation

5.3003.6a	Verification	580
-----------	--------------------	-----

5.3003.7 Occupant Education

5.3003.7a	Basic operation	581
5.3003.7b	System controls (e.g., thermostat, humidistat)	582
5.3003.7c	System disconnects	583
5.3003.7d	Combustion air inlets	584
5.3003.7e	Blocking air flow	585
5.3003.7f	Routine maintenance	586
5.3003.7g	Calling heating, ventilation, and air conditioning (HVAC) contractor	587
5.3003.7h	Carbon monoxide (CO)	588
5.3003.7i	Warranty and service	589

5.3003.11 Heating and Cooling Controls

5.3003.11a	Removal of mercury-based thermostats	590
5.3003.11b	Removal of existing controls	591
5.3003.11c	Penetrations	592

Table of Contents

5.3003.11d Thermostat location 593

5.3003.11e Blower speed 594

5.3003.11f Thermostat selection: heat pump 595

5.3003.11g Heat pump: supplementary heat 596

5.3003.11h Heat pump: low ambient compressor lockout 597

5.3003.11i Heat pump: outside temperature sensor 598

5.3003.11j Heat pump: supplementary heat wiring 599

5.3003.11k Thermostat: installer programming 600

5.3003.11l Time delay settings 601

5.3003.11m Humidistat: location 602

5.3003.11n Ventilation control 603

5.3003.11o Occupant education 604

5.3003.12 Package Units—Repair and Service

5.3003.12a Work assessment 605

5.3003.12b Remove existing system components 606

5.3003.12c Repairs 607

5.3003.12d Service existing components 608

5.3003.12e Commissioning 609

5.3003.13 Refrigerant Charge Evaluation

5.3003.13a Prerequisite 610

5.3003.13b Qualified contractor 611

5.3003.13c Documentation 612

5.3003.13d Quality assurance 613

5.3003.14 Combustion Analysis of Gas-Fired Appliances (LP and Natural Gas)

5.3003.14a Place appliance in operation 614

5.3003.14b Gas pressure 616

5.3003.14c Carbon dioxide (CO₂) and oxygen (O₂) 618

5.3003.14d Excess combustion air 619

5.3003.14e Carbon monoxide (CO) in flue gas 620

5.3003.14f Testing/inspection holes 622

5.3003.15 Combustion Analysis of Oil-Fired Appliances

5.3003.15a Oil system: smoke test 624

5.3003.15b Oil system: nozzle 626

5.3003.15c Oil filter 627

5.3003.15d Fuel pressure 628

5.3003.15e Oil system: steady state efficiency (SSE) 629

5.3003.15f Net stack temperature 630

5.3003.15g Carbon dioxide (CO₂) and oxygen (O₂) 631

5.3003.15h Excess combustion air 632

5.3003.15i CO in flue gas 633

5.3003.15j Testing/inspection holes 634

5.3003.16 Evaluating Electrical Service

5.3003.16a Service entrance 636

5.3003.16b Polarity 637

5.3003.16c Voltage: incoming power 638

5.3003.16d Voltage: contactor 639

5.3003.16e Grounding..... 640
 5.3003.16f Blower amperage 641
 5.3003.16g Compressor amperage..... 642
 5.3003.16h Door switch operation..... 643
 5.3003.16i Heat pump: emergency heat..... 644

5.32 Shading

5.3202 Reflective Roofs

5.3202.1 Reflective Coatings on Metal Roofs

5.3202.1a Assessment..... 645
 5.3202.1b Preparation..... 646
 5.3202.1c Materials selection..... 647
 5.3202.1d Application..... 648
 5.3202.1e Occupant education 649

6 Ventilation

6.60 Exhaust

6.6002 Components

6.6002.3 Exhaust-Only Ventilation—Fan Intake Grille Location

6.6002.3a Primary whole house ventilation..... 650
 6.6002.3b Local ventilation..... 651

6.6002.4 Ducts (Exhaust Fans)

6.6002.4a Duct design and configuration..... 652
 6.6002.4b Duct insulation..... 653
 6.6002.4c Duct support..... 654
 6.6002.4d Duct connections..... 655
 6.6002.4e Duct materials..... 657
 6.6002.4f Total exhaust airflow 659

6.6003 Fans

6.6003.1 Surface-Mounted Ducted

6.6003.1a Hole through interior surface..... 660
 6.6003.1b Wiring 662
 6.6003.1c Fan mounting 663
 6.6003.1d Backdraft damper 664
 6.6003.1e Duct-to-fan connection 665
 6.6003.1f Fan housing seal..... 667
 6.6003.1g Fan to interior surface seal..... 668
 6.6003.1h Air flow..... 669
 6.6003.1i Preventing air leakage caused by exhaust fans..... 671
 6.6003.1j Combustion safety..... 672

6.6003.2 Inline

6.6003.2a Wiring 674
 6.6003.2b Access..... 675
 6.6003.2c Fan mounting 676
 6.6003.2d Backdraft damper 677

Table of Contents

6.6003.2e	Duct connections	678
6.6003.2f	Boot to interior surface seal	679
6.6003.2g	Air flow	680
6.6003.2h	Preventing air leakage caused by exhaust fans	682
6.6003.2i	Combustion safety	683
6.6003.5	Garage Exhaust Fan	
6.6003.5a	System selection	685
6.6003.5b	Air leakage	686
6.6003.5c	Combustion safety	688
6.6003.6	Fan Placement (Whole House/Common Space Exhaust Only)	
6.6003.6a	Clearance	690
6.6003.6b	Power source	691
6.6003.6c	Location	692
6.6003.6d	Duct/vent	693
6.6003.6e	Attachment	694
6.6003.6f	Total exhaust airflow	695
6.6005	Appliance Exhaust Vents	
6.6005.1	Clothes Dryer	
6.6005.1a	Clothes dryer ducting	697
6.6005.1b	Termination fitting	700
6.6005.1c	Makeup air	702
6.6005.1d	Combustion safety	703
6.6005.1e	Occupant education	705
6.6005.2	Kitchen Range	
6.6005.2a	Wiring	707
6.6005.2b	Fan venting	708
6.6005.2c	Fan ducting	709
6.6005.2d	Termination fitting	712
6.6005.2e	Makeup air	713
6.6005.2f	Combustion safety	714
6.6005.2g	Occupant education	716
6.61	Supply	
6.6102	Components	
6.6102.4	Intake for Ventilation Air to Forced Air System Used for Heating or Cooling	
6.6102.4a	Forced air system requirements	717
6.6102.4b	Wiring	718
6.6102.4c	Access	719
6.6102.4d	Mounting intake duct	720
6.6102.4e	Motorized damper	721
6.6102.4f	Intake filter	722
6.6102.4g	Occupant education	723
6.6102.4h	Intake ventilation airflow	724

6.6188 Special Considerations**6.6188.2 Removing Supply Vents from Garages**

6.6188.2a	Removal of supply/return in garage	725
6.6188.2b	Patching of the hole in the duct system created by removal	726
6.6188.2c	Sealing of the patch.....	727
6.6188.2d	Removal of discarded ducts	728
6.6188.2e	Patching of the register hole in garage.....	729
6.6188.2f	External static pressure testing	730
6.6188.2g	CAZ testing.....	731

6.62 Whole Building Ventilation**6.6204 Equipment Evaluation****6.6204.1 Commissioning Existing Exhaust or Supply Ventilation Systems**

6.6204.1a	Systems check	732
6.6204.1b	Verify flow rate.....	733
6.6204.1c	Work order.....	734
6.6204.1d	Total ventilation airflow	735

6.6205 Exhaust-Only System**6.6205.1 Manufactured Housing Exhaust-Only Strategies**

6.6205.1a	Assessment.....	736
6.6205.1b	Selection.....	738
6.6205.1c	Location.....	739
6.6205.1d	Climate considerations	741
6.6205.1e	Combustion Appliance Zone (CAZ) testing	742
6.6205.1f	Occupant education	743
6.6205.1g	Total exhaust airflow	744

6.6206 Equipment Removal**6.6206.1 Decommissioning Existing Exhaust or Supply Ventilation Systems**

6.6206.1a	Power supply	746
6.6206.1b	Removal	747
6.6206.1c	Repair.....	748
6.6206.1d	Combustion Appliance Zone (CAZ) testing	749

6.6288 Special Considerations**6.6288.2 Sound Ratings—New Fan Installation**

6.6288.2a	Primary ventilation system/continuously operating fan	750
6.6288.2b	Intermittent spot ventilation system	751

6.99 Additional Resources**6.9901 Codes and Standards Resources****6.9901.1 Supplemental Ventilation Information—ASHRAE 62.2**

6.9901.1a	Ventilation fan flow rate	752
-----------	---------------------------------	-----

7 Baseload

7.80 Plug Load

7.8001 Refrigerators/Freezers

7.8001.1 Refrigerator and Freezer Replacement

7.8001.1a Selection	753
7.8001.1b Installation	754
7.8001.1c Decommissioning	755
7.8001.2 Cleaning and Tuning Existing Refrigerators and Freezers	
7.8001.2a Clean and tune	756

7.8002 Electronics

7.8002.1 Entertainment and Computer Systems and Components Replacement

7.8002.1a Selection	757
7.8002.1b Installation	758
7.8002.1c Decommissioning	759

7.8003 Lighting

7.8003.1 Lighting Upgrade

7.8003.1a Daylighting	760
7.8003.1b Selection	761

7.8004 Laundry

7.8004.1 Washing Machine

7.8004.1a Selection	763
7.8004.1b Installation	764
7.8004.1c Decommissioning	765

7.8004.2 Clothes Dryer Replacement

7.8004.2a Selection	766
7.8004.2b Installation	767
7.8004.2c Decommissioning	769

7.81 Water Heating

7.8101 Water Use Reduction

7.8101.1 Shower Head and Faucet Aerator

7.8101.1a Work assessment	770
7.8101.1b Selection	771
7.8101.1c Installation	772
7.8101.1d Decommissioning	775

7.8102 Installation and Replacement

7.8102.1 Water Heater Selection

7.8102.1a Selection parameters	776
7.8102.1b Product selection	778

7.8102.2 Storage-Type Appliance

7.8102.2a Hazardous material removal	779
7.8102.2b Equipment removal	780
7.8102.2c New equipment installation	781

Table of Contents

7.8102.2d	Emergency drain pan	782
7.8102.2e	Expansion tank	783
7.8102.2f	Temperature and pressure relief valve.....	784
7.8102.2g	Dielectric unions	786
7.8102.2h	Backflow prevention	787
7.8102.2i	Thermal efficiency	788
7.8102.2j	Fuel supply	791
7.8102.2k	Discharge temperature.....	792
7.8102.2l	Commissioning of system.....	794
7.8102.2m	Occupant safety	795
7.8102.2n	Occupant education	796
7.8102.3	On-Demand Appliance	
7.8102.3a	Hazardous material removal	797
7.8102.3b	Equipment removal	798
7.8102.3c	New equipment installation	799
7.8102.3d	Emergency drain pan	800
7.8102.3e	Temperature and pressure relief valve.....	801
7.8102.3f	Dielectric unions	803
7.8102.3g	Backflow prevention and pressure regulator	804
7.8102.3h	Thermal efficiency	805
7.8102.3i	Required combustion air	806
7.8102.3j	Venting of flue gases	809
7.8102.3k	Flue gas testing	811
7.8102.3l	Electric and fossil fuel supply	813
7.8102.3m	Cold water supply	814
7.8102.3n	Discharge temperature.....	815
7.8102.3o	Commissioning of system.....	816
7.8102.3p	Ambient CO	817
7.8102.3q	Occupant education	818
7.8103	Maintenance/Inspection	
7.8103.1	Storage-Type Appliance	
7.8103.1a	Health and safety	819
7.8103.1b	Visual inspection	820
7.8103.1c	Thermal efficiency	822
7.8103.1d	Potable water expansion tank	825
7.8103.1e	Temperature and pressure relief valve.....	827
7.8103.1f	Maintenance records	829
7.8103.1g	Occupant safety	830
7.8103.1h	Occupant education	831
7.8103.2	On-Demand Appliance	
7.8103.2a	Health and safety	832
7.8103.2b	Visual inspection	833
7.8103.2c	Temperature and pressure relief valve.....	835
7.8103.2d	Flue gas testing	838
7.8103.2e	Required combustion air	840

Table of Contents

7.8103.2f	Venting of flue gases	843
7.8103.2g	Fuel supply	845
7.8103.2h	Cold water supply	847
7.8103.2i	Discharge temperature	848
7.8103.2j	Test the system safety and operation	850
7.8103.2k	Maintenance records	851
7.8103.2l	Occupant health and safety	852
7.8103.2m	Occupant education	853

2.0100.2a

Desired Outcome:

Work completed safely without injury or hazardous exposure

Specification(s):

Design will be incorporated to eliminate or minimize hazards (e.g., material selection, access to equipment for installation and maintenance, placement of equipment, ductwork and condensate lines)

Objective(s):

Prevent worker injury

Reduce risk of exposure to toxic substances and physical hazards

2.0100.2b

Desired Outcome:

Work completed safely without injury or hazardous exposure

Specification(s):

Durable and wrist-protecting gloves will be worn that can withstand work activity

Objective(s):

Minimize skin contact with contaminants

Protect hands from sharp objects



Unsafe

Recognize potential risks



Safe

Wear appropriate hand protection

2.0100.2b - Hand protection



GOOD: Wear nitrile gloves when handling mastic



Inspect gloves for holes and damage to minimize risk

2.0100.2c

Desired Outcome:

Work completed safely without injury or hazardous exposure

Specification(s):

If the risk of airborne contaminants cannot be prevented, proper respiratory protection will be provided and worn (e.g., N-95 or equivalent face mask)

When applying low pressure 2-component spray polyurethane foam, air purifying masks with an organic vapor cartridge and P-100 particulate filter will be used

Objective(s):

Minimize exposure to airborne contaminants (e.g., insulation materials, mold spores, feces, bacteria, chemicals)



Unsafe

Workers need to properly protect their airways when retrofitting



Best Practice

Retrofits can have multiple different respiratory protection requirements

2.0100.2c - Respiratory protection



Whenever airborne contaminants are a possibility, wear an N-95 mask



For two-component spray insulation, P-100 respirators should be used



All P-100s should be fitted to the individual worker



When working with high-pressure spray foam, use a Supplied Air Respirator



When unsure what level of protection is necessary, check the SDS

2.0100.2d

Desired Outcome:

Work completed safely without injury or hazardous exposure

Specification(s):

If contaminants are present (e.g., insulation materials), removable protective clothing will be worn

Eye protection will always be worn (e.g., safety glasses, goggles if not using full-face respirator)

Objective(s):

Protect worker from skin contact with contaminants

Minimize spread of contaminants

Provide eye protection



This worker has donned some PPE, but is not fully protected.



The worker has donned proper PPE, and is fully protected.

Tools:

1. Safety Glasses or Goggles
2. Disposable Coverall
3. Gloves
4. Shoe Covers
5. Ear Plugs (situation-dependent)

2.0100.2d - Personal protective equipment (PPE)



Select the proper PPE according to the task to be performed. More volatile substances require more protection.

2.0100.2e

Desired Outcome:

Work completed safely without injury or hazardous exposure

Specification(s):

Spaces with limited ingress and egress and restricted work area will be considered confined space

Access and egress points will be located before beginning work

Inspection will be conducted for hazards, such as damaged or exposed electrical conductors, mold, sewage effluent, friable asbestos or fiberglass, pests, and other potential hazards

Adequate ventilation will be provided

Use of toxic material will be reduced

Objective(s):

Provide adequate access and egress points

Reduce risk to the workers in the confined space

Prevent buildup of toxic or flammable contaminants

Prevent electrical shock



Unsafe

Inspect confined spaces for safety concerns and hazards before work begins

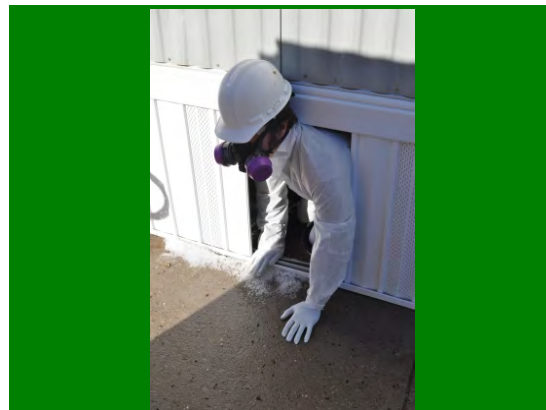

Best Practice

Ensure proper personal protective equipment is worn and that workers are aware of ingress and egress points

Tools:

1. Flashlight
2. Ventilator

From OSHA.gov: "Many workplaces contain areas that are considered "confined spaces" because while they are not necessarily designed for people, they are large enough for workers to enter and perform certain jobs. A confined space also has limited or restricted means for entry or exit and is not designed for continuous occupancy."

<https://www.osha.gov/SLTC/confinedspaces/index.html>

2.0100.2e - Confined space safety



Spaces with limited ingress and egress will be considered confined



Locate all ingress and egress points before work begins



Inspect work space for hazards and safety concerns before work begins



Provide adequate ventilation

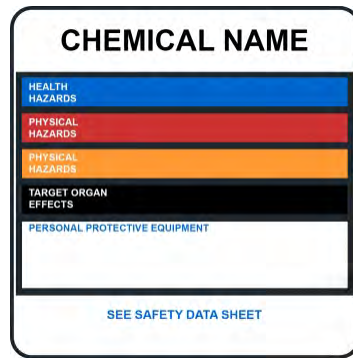

Check safety labels and avoid the use of toxic materials



Do NOT use hazardous materials in confined spaces -- particularly those carrying these GHS warnings

2.0100.2f

Desired Outcome:

Work completed safely without injury or hazardous exposure

Specification(s):

Power tools will be inspected and used in accordance with manufacturer specifications to eliminate hazards associated with missing ground prongs, ungrounded circuits, misuse of power tools, noise, and improper or defective cords or extension cords

All devices used will be verified as GFCI protected or double insulated

Exhaust gases from compressors and generators will be prevented from entering interior space

Objective(s):

Prevent power tool injuries

Prevent buildup of toxic or flammable contaminants



Bad Practice

Worker is using a circular saw with no eye or ear protection, and is not properly supporting the material to be cut.

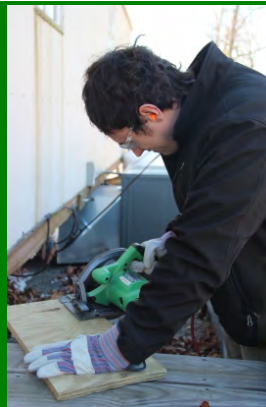

Best Practice

Worker is cutting off of a stable surface, with appropriate eye and ear protection.

2.0100.2f - Power tool safety



Inspect power and extension cords closely for damage. Follow manufacturer's instructions for repair or replacement.



Generator has been moved off the trailer to ensure no buildup of harmful exhaust gases.



Make sure tools are GFCI-protected or double insulated

2.0100.2g

Desired Outcome:

Work completed safely without injury or hazardous exposure

Specification(s):

The least toxic suitable material will be chosen

Hazardous materials will be handled in accordance with manufacturer specifications or MSDS standards to eliminate hazards associated with volatile organic compounds (VOCs), sealants, insulation, contaminated drywall, dust, foams, asbestos, lead, mercury, and fibers

Appropriate personal protective equipment (PPE) will be provided

Workers will be trained on how to use PPE

Workers will be expected to always use appropriate PPE during work

Objective(s):

Prevent worker exposure to toxic substances

2.0100.2h

Desired Outcome:

Work completed safely without injury or hazardous exposure

Specification(s):

Appropriate PPE will be used (e.g., knee pads, bump caps, additional padding)

Proper equipment will be used for work

Proper lifting techniques will be used

Objective(s):

Prevent injuries from awkward postures, repetitive motions, and improper lifting



Unsafe

Workers will take precautions to protect themselves on the job site



Best Practice

Hard hats, knee pads, bump caps, and team lifts help to prevent injury

Visit <https://www.osha.gov/SLTC/ergonomics/controlhazards.html> for additional guidance.

2.0100.2i

Desired Outcome:

Work completed safely without injury or hazardous exposure

Specification(s):

Hand tools will be used for intended purpose

Objective(s):

Prevent injuries



Using tools for other than their intended purpose is dangerous

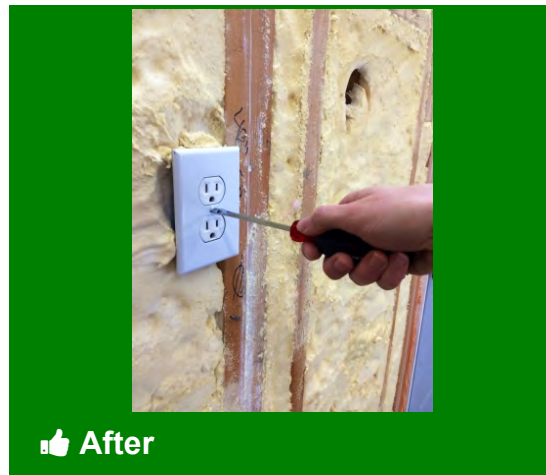

Use tools in a manner consistent with their intended purpose

Using hand tools only in a manner consistent with their intended purpose. Doing otherwise can cause serious injuries, damage to the tools, damage to materials and equipment. Besides being unsafe, the practice represents poor workmanship and leads to low quality results.

2.0100.2j

Desired Outcome:

Work completed safely without injury or hazardous exposure

Specification(s):

Caution will be used around power cords, hoses, tarps, and plastic sheeting

Precautions will be taken when ladders are used, when working at heights, or when balancing on joists

Walk boards will be used when practical

When scaffolding is used, manufacturer set-up procedures will be followed

Appropriate footwear and clothing will be worn

Objective(s):

Prevent injuries due to slips, trips, and falls

2.0100.2k

Desired Outcome:

Work completed safely without injury or hazardous exposure

Specification(s):

Ensure staff is aware of risks during summer months, including the symptoms of heat stroke and heat exhaustion

Appropriate ventilation, hydration, rest breaks, and cooling equipment will be provided

911 will be dialed when necessary

Objective(s):

Prevent heat stroke, heat stress, and cold stress related injuries



Attics and crawl spaces can be dangerous work places in the heat



Keep workers comfortable with hydration and cool vests

2.0100.21

Desired Outcome:

Work completed safely without injury or hazardous exposure

Specification(s):

Ignition sources will be identified and eliminated (e.g., turn off pilot lights, space heaters, and fuel supply)

Use of flammable material will be reduced and fire-rated materials will be used

Objective(s):

Prevent a fire hazard



Unsafe

Fire hazards like this should be removed from the work area with the permission and/or assistance of the homeowner.



After

After potentially dangerous items have been removed, set combustion appliances to off or pilot to minimize risk of fire.

2.0100.2I - Fire safety



Remove items in close proximity to flue pipes with homeowner permission and/or assistance.



Turn wall mounted heaters off.



Sometimes it may even be necessary to turn the fuel supply off to service an appliance.



When sealing around heat sources like flue pipes, code approved fire rated materials should always be used.

2.0100.2m

Desired Outcome:

Work completed safely without injury or hazardous exposure

Specification(s):

The source of all contaminants (e.g., sewage, dead animals, needles) will be corrected, repaired, or removed before performing inspections that require complete access to the crawl space

If appropriate, the contaminant will be neutralized and/or a protective barrier will be installed in the area

Objective(s):

Ensure worker safety

Prevent worker exposure to hazards

2.0103.1a

Desired Outcome:

Work completed safely without injury or hazardous exposure

Specification(s):

All worker safety specifications in Global Worker Safety section will be followed

Objective(s):

Prevent injury

Minimize exposure to health and safety hazards

2.0104.1a

Desired Outcome:

Work is completed safely without injury or hazardous exposure

Specification(s):

Follow all worker safety specifications in Global Worker Safety section

Objective(s):

Prevent injury

Minimize exposure to health and safety hazards

2.0104.1b

Desired Outcome:

Work is completed safely without injury or hazardous exposure

Specification(s):

OSHA asbestos abatement protocol 29 CFR 1926.1101 will be followed if vermiculite insulation is present

If unsure whether material contains asbestos, a qualified asbestos professional will be contacted to assess the material and to sample and test as needed

When working around asbestos-containing material (ACM), the following will not be done:

- Dust, sweep, or vacuum debris
- Saw, sand, scrape, or drill holes in the material
- Use abrasive pads or brushes to strip materials

Attic insulation that looks like vermiculite (as opposed to fiberglass, cellulose, or urethane foams) will not be removed or disturbed

Objective(s):

Protect workers from toxic exposure

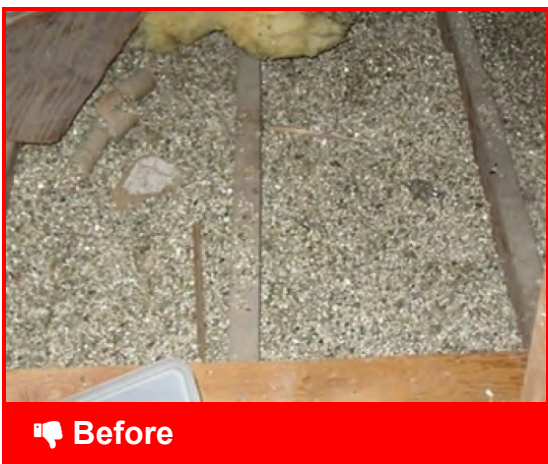

Material identified as vermiculite may contain asbestos



If asbestos is suspected, call an EPA-accredited professional

Observe OSHA 29CFR 1926.1101 abatement protocol when asbestos is suspected.

2.0104.1b - Vermiculite



Do not disturb vermiculite by vacuuming, dusting, or sweeping



Do not disturb vermiculite by drilling, sanding, scraping, sawing, etc.

2.0104.1c

Desired Outcome:

Work is completed safely without injury or hazardous exposure

Specification(s):

All materials will be handled in accordance with manufacturer specifications or Material Safety Data Sheet (MSDS) standards to eliminate hazards associated with incorrect, defective, or improperly used respirator and personal protective equipment (PPE)

Objective(s):

Protect workers from toxic exposure

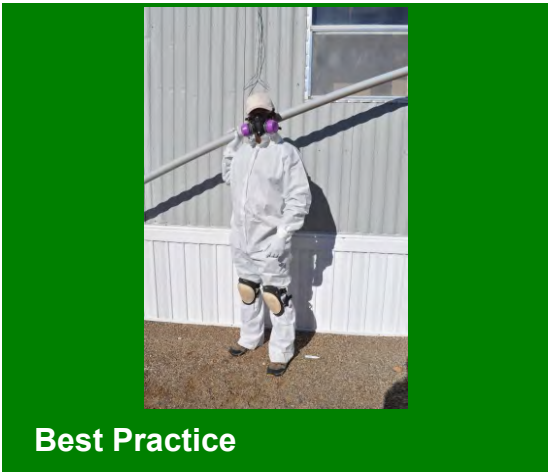

Best Practice

Ensure workers wear appropriate masks or respirators for the material with which they are working

The new Global Harmonization System now calls MSDS simply SDS. The two terms may be used interchangeably for a period, but SDS is now the proper term.

2.0104.1c - Respiratory protection



Check SDS for materials to be used during retrofit to determine what PPE is necessary

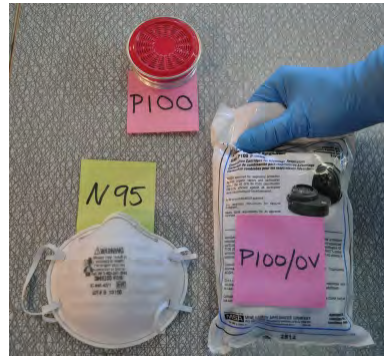

Wear respirator or mask appropriate to the materials being used

2.0104.1d

Desired Outcome:

Work is completed safely without injury or hazardous exposure

Specification(s):

Presence of lead based paint in pre-1978 homes will be assumed unless testing confirms otherwise

The Environmental Protection Agency (EPA) Renovation, Repair, and Painting (RRP) Program Rule (40 CFR Part 745) in pre-1978 homes and proposed changes to this rule (Federal Register/Vol. 75, No. 87/May 6, 2010) will be complied with, to be superseded by any subsequent final rulemaking or any more stringent state or federal standards

Objective(s):

Protect workers and occupants from potential lead hazards



In homes built before 1978, test paint before beginning renovation

Tools:

1. Note: Mask must be worn during testing
2. LeadCheck test kit
3. Utility knife
4. Camera

EPA RRP certification required to conduct Lead Paint assessment.

2.0104.1d - Lead paint assessment



1
Clean tools and sample site to prevent contamination



2
Cut sample site at an angle to expose all older paint layers



3
Break capsules and shake to mix reagents. Swab sample site for 30 seconds



4
Check swab for reaction



5
Red indicates lead positive. White indicates lead negative



6
If negative, verify validity of test with provided calibration card



7
Lead in calibration card should test positive and turn red

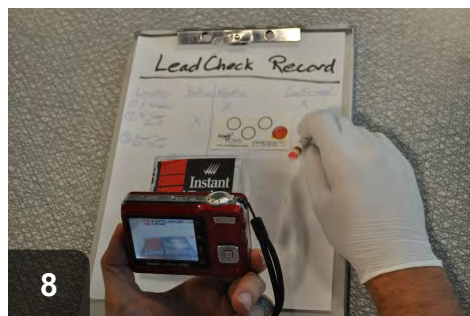

8
Record test results to maintain documentation

2.0105.3a

Desired Outcome:

Work completed safely without injury or hazardous exposure

Specification(s):

All worker safety specifications in Global Worker Safety section will be followed

Objective(s):

Prevent injury

Minimize exposure to health and safety hazards

2.0105.4a

Desired Outcome:

Work completed safely without injury or hazardous exposure

Specification(s):

Follow all worker safety specifications in Global Worker Safety section

Objective(s):

Prevent injury

Minimize exposure to health and safety hazards

2.0105.4b

Desired Outcome:

Work completed safely without injury or hazardous exposure

Specification(s):

Identify and dispose of any mercury-containing thermostats in accordance with Environmental Protection Agency (EPA) guidance

Objective(s):

Protect worker and occupant from mercury exposure



Unsafe

Mercury thermostats should be replaced and disposed of properly



Unsafe

Do NOT dispose of mercury thermostats in the trash--find local recycling

Paraphrased from 40 CFR 273.14: A universal waste mercury-containing thermostat or container containing only universal waste mercury-containing thermostats should be labeled or marked clearly with any of the following phrases: "Universal Waste-Mercury Thermostat(s)," "Waste Mercury Thermostat(s)," or "Used Mercury Thermostat(s)." **Contact thermostat-recycle.org or earth911.org for recycling options.

2.0105.4c

Desired Outcome:

Work completed safely without injury or hazardous exposure

Specification(s):

Suspected asbestos hazards will be identified in furnaces (e.g., gaskets), wood stoves, zonal heating devices, electrical wiring insulation, boilers, and pipe insulation and corrected in accordance with EPA guidance

Workers will take precautionary measures to avoid exposure

Objective(s):

Protect worker and occupant from asbestos exposure



Unsafe

Have an AHERA-certified professional test all areas with suspected asbestos. Remediate in accordance with EPA rules.

2.0105.4d

Desired Outcome:

Work completed safely without injury or hazardous exposure

Specification(s):

Gloves will be worn when working with metal ducts

Workers will wear personal protective equipment (PPE) as needed to protect themselves against exposure to hazards (e.g., pests, sewage, flooded duct work, mold, chemicals, scat, viruses)

Long sleeves and long pants should be worn as additional protection from liquid nitrogen and other hazardous materials

Objective(s):

Protect worker from exposure to hazards

Protect worker from skin contact with liquid nitrogen



Unsafe

When working with refrigerants, short sleeves are inappropriate



Safe

When working with refrigerants, workers should dress appropriately

2.0105.4d - Personal protective equipment (PPE)



Wear work gloves when working with metal ducts



Assess the site and situation to determine proper PPE to minimize risks

2.0105.4e

Desired Outcome:

Work completed safely without injury or hazardous exposure

Specification(s):

Worker will check for presence of combustible gas leaks before work begins

Leaks will be repaired before work is performed

Objective(s):

Protect worker and occupant from exposure to hazards



Unsafe

Fuel leaks need to be repaired



Safe

Repairs need to be tested and verified to no longer leak

Tools:

1. Combustion gas detector
2. Spray bottle

Materials:

1. Noncorrosive leak detection fluid

Paraphrased from 2012 IRC G2417: Leakage will be located using an *approved* combustible gas detector, a noncorrosive leak detection fluid or an equivalent nonflammable solution. Matches, candles, open flames or other methods that could provide a source of ignition cannot be used. Where leakage or other defects are located, the affected portion of the *pipng system* will be repaired or replaced and retested.

2.0105.4e - Combustible gas detection

Measures

Measure 12 Repair - Gas Leak in Crawlspace (flagged)

Comment

#	Material / Labor	Description /Comment	Units
1	Unspecified	Misc Material	Each

Fuel leaks discovered during initial audit should be flagged



Use approved combustion gas sniffer to see if repaired line still leaks



Repeatedly test repair site for leakage over a 10min period



Allow testing solution to sit on newly repaired pipe joint for 10min



Confirm repair and remove flag

2.0105.4f

Desired Outcome:

Work completed safely without injury or hazardous exposure

Specification(s):

Workers will check for presence of ambient CO before and during work

CO issues will be addressed before work is performed or continued

Objective(s):

Protect worker and occupant from exposure to hazards



STOP WORK if CO levels are higher than 35ppm!!



If excessive level of CO are found, remediate problems before work continues

Tools:

1. CO meter

2.0105.4f - Carbon monoxide (CO)



1 Test for CO in entire home, particularly around combustion appliances



2 If CO issues are found, clean and tune appliances to remediate issues



3 All workers should wear personal ambient CO monitors and halt work if levels exceed 35ppm

2.0105.4g

Desired Outcome:

Work completed safely without injury or hazardous exposure

Specification(s):

Pipes will be sealed by a certified professional with an approved fastening process and sealant in accordance with manufacturer specifications (International Fuel Gas Code)

Gas lines will be leak free when tested with an electronic combustible gas leak detector and verified with bubble solution

OR

Gas lines will be leak free when tested by a standing pressure test that meets the approval of the local code

Objective(s):

Install gas lines with no leaks

2.0105.4h

Desired Outcome:

Work completed safely without injury or hazardous exposure

Specification(s):

A secondary LP safety detector system (valve, exhaust fan, alarm light) will be installed by a certified professional for propane piping installed below grade

Shut off valves will be installed by a certified professional at each gas appliance (ANSI Z21.15)

Objective(s):

Detect accumulation of dangerous levels of propane in below-grade areas

Isolate appliances from the rest of the system for emergencies, removal, or repairs

2.0106.1a

Desired Outcome:

Work completed safely without injury or hazardous exposure

Specification(s):

Follow all worker safety specifications in Global Worker Safety section

Objective(s):

Prevent injury

Minimize exposure to health and safety hazards

2.0110.1a

Desired Outcome:

Occupant and worker risk from hazardous materials minimized

Specification(s):

Materials that do not create long-term health risks for occupants and workers will be used

Objective(s):

Improve indoor air quality in the living space

2.0110.1b

Desired Outcome:

Occupant and worker risk from hazardous materials minimized

Specification(s):

Manufacturer specifications will be followed

Objective(s):

Reduce risk of exposure to harmful substances

Follow safety procedures

2.0110.1c

Desired Outcome:

Occupant and worker risk from hazardous materials minimized

Specification(s):

MSDSs will be provided onsite and available during all work

Objective(s):

Assess exposure risk

Prepare a response in case of emergency

2.0111.5a

Desired Outcome:

Manufactured home is properly installed

Specification(s):

Any installation deficiencies that may affect worker safety or integrity or installed measures will be repaired before starting work

Objective(s):

Ensure site is safe and ready for upgrade



The concrete pad is not centered under the pier, rendering the pier susceptible to tilting or collapse



Approved, properly installed piers, anchors, and tie downs

Tools:

1. Level
2. Cordless driver drill
3. Flashlight

Inspect homes for safety before work. Look for stuck doors and windows, buckled siding, and loose tie-downs as evidence of settling. Inspect piers to ensure that they are solid and level. Check for loose or missing wooden shims and wedges. Inspect anchors and straps for tightness and proper installation per manufacturer's recommendations.

2.0111.5a - Installation deficiencies



Carefully inspect the foundation piers. Look for loose or missing shims and wedges

2.0111.5b

Desired Outcome:

Manufactured home is properly installed

Specification(s):

Home must be stabilized in accordance with manufacturer specifications or local authority having jurisdiction

Objective(s):

Ensure the home is secured properly

Prevent injury

Minimize exposure to health and safety hazards



Unsafe
Unstable mobile homes are unsafe work environments. Do not crawl under mobiles that are not stabilized



Safe
Properly stabilized homes have a solid foundation and have anchored straps, unless otherwise indicated by manufacturer

2.0201.2a

Desired Outcome:

Buildup of dangerous combustion byproducts in the living space prevented

Specification(s):

Combustion air will be provided from the outside and, where applicable, in accordance with the 2012 IRC for the type of appliance installed

Objective(s):

Prevent combustion byproducts from entering the house

Image 1: For homes with one permanent opening, see 2012 IRC: G2407.6.2 (304.6.2): a minimum free area of 1 in² per 3,000 Btu/h (734 mm²/kW) of total input rating of all appliances

Image 2: For homes with two permanent vertical duct openings, see 2012 IRC G2407.6.1 (304.6.1): a minimum free area of 1 in² per 4,000 Btu/h (550 mm²/kW) of total input rating of all appliances

Image 3: For homes with two permanent horizontal duct openings, see 2012 IRC G2407.6.1 (304.6.1): a minimum free area of 1 in² per 2,000 Btu/h (1,100 mm²/kW) of total input rating of all appliances

2.0201.2a - Outside combustion makeup air

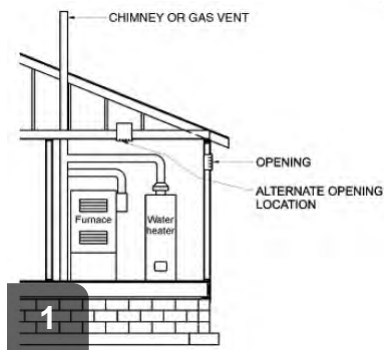

min free area of 1 sqin per 3,000 Btu/h
(734 mm²/kW) of total input rating

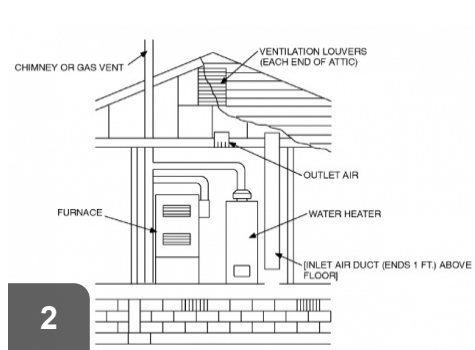

min free area of 1 sqin per 4,000 Btu/h
(550 mm²/kW) of total input rating

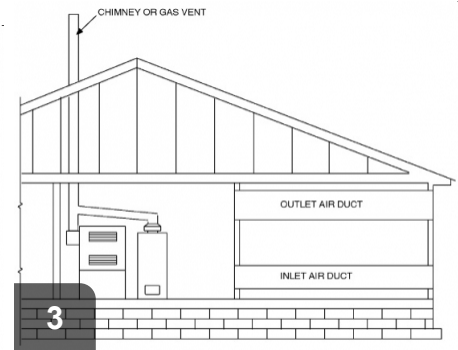

min free area of 1 sqin per 2,000 Btu/h
(1100 mm²/kW) of total input rating

2.0201.2b

Desired Outcome:

Buildup of dangerous combustion byproducts in the living space prevented

Specification(s):

If replacing appliances, a sealed-combustion, direct-vent appliance will be installed in accordance with manufacturer specifications, 2012 IRC G2427.8, and additional applicable codes

Replacement equipment venting will be assessed to ensure other existing equipment is not adversely affected

Objective(s):

Prevent combustion byproducts from entering the house



 Before

Damaged combustion appliances beyond repair should be replaced



 After

Sealed-combustion, direct-vent appliances should replace unsafe appliances

Tools:

1. Digital manometer and air line tubing
2. Personal carbon monoxide detector
3. Combustion analyzer
4. Combustible gas leak detector

Always perform combustion safety testing on newly installed equipment to ensure it is performing properly.

2.0201.2b - New appliances



Two-pipe 90% efficiency furnaces are viable replacement appliances



Direct vent combustion appliances are also viable replacements

2.0201.2c

Desired Outcome:

Buildup of dangerous combustion byproducts in the living space prevented

Specification(s):

CO detection or warning equipment will be installed outside of each separate sleeping area in the immediate vicinity of the bedrooms in accordance with ASHRAE 62.2 and authority having local jurisdiction

Installation will be accomplished by a licensed electrician when required by local code

Objective(s):

Alert occupant to CO exposure



Best Practice

Carbon Monoxide alarms should be installed according to local codes

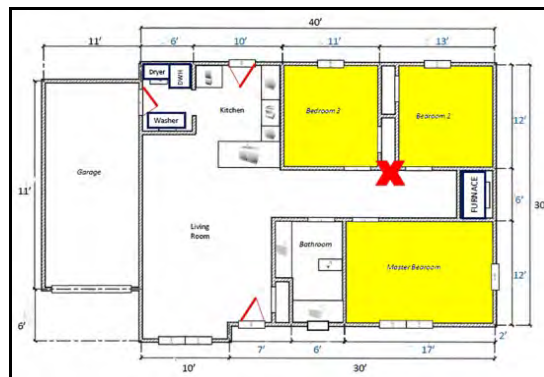

Best Practice

Alarms should be mounted near sleeping areas--such as the one marked in red

2.0201.2d

Desired Outcome:

Buildup of dangerous combustion byproducts in the living space prevented

Specification(s):

Gas ovens will be tested for CO

A clean and tune will be conducted if measured CO in the undiluted flue gases of the oven vent at steady state exceeds 200 ppm or 800 ppm by air-free measurement

Objective(s):

Ensure clean burn of gas ovens

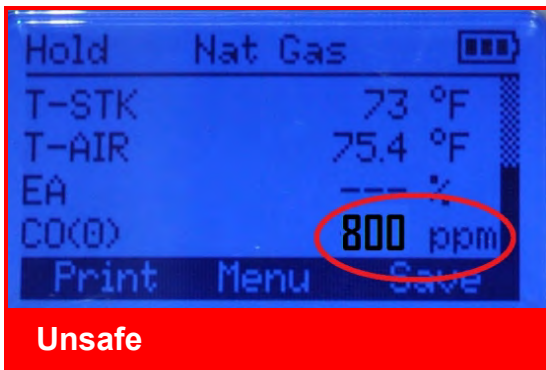

If air-free CO reading exceeds 800ppm, order a clean and tune



Test gas oven for carbon monoxide using a combustion gas analyzer

Tools:

1. Combustion analyzer with probe

2.0201.2e

Desired Outcome:

Buildup of dangerous combustion byproducts in the living space prevented

Specification(s):

Specify clean and tune if the flame has any discoloration, flame impingement, an irregular pattern, or if burners are visibly dirty, corroded, or bent

Objective(s):

Ensure clean burn and operation of gas range burners



Discoloration is a clear sign that a gas range needs a clean and tune



A properly operating gas range burner should have an even blue flame

2.0201.2e - Gas range burners



Yellow, uncontrolled flames indicate the need for a clean and tune



Gas ranges should be cleaned and tuned if improper operation is evident



Blue, even flames indicate burners are working properly

2.0201.2f

Desired Outcome:

Buildup of dangerous combustion byproducts in the living space prevented

Specification(s):

Replacement of solid fuel-burning appliance with UL-listed and EPA- certified appliances if the existing appliance is not UL-listed or has signs of structural failure

Objective(s):

Ensure safe operations of solid fuel-burning appliances



Unsafe solid fuel burning appliances should be replaced



New appliances should be UL-listed and EPA-certified

Since 1988, the EPA has regulated particulate emissions from wood heaters. The limit is 7.5 grams per hour for non-catalytic appliances, and 4.1 grams per hour for catalytic appliances.

Follow all manufacturer's installation specifications, especially regarding venting, mounting surfaces, and distance to surrounding surfaces.

2.0201.2f - Solid fuel-burning appliances



Locate data plate to find out appliance ratings

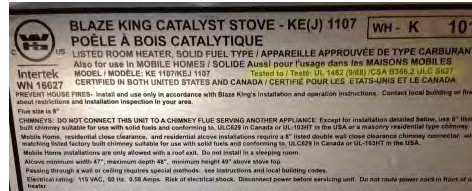

Check appliance rating plates for EPA and UL markings
(or CSA, ETL, or WH markings)

2.0201.3a

Desired Outcome:

Accurate information about appliance safe operation is gathered

Specification(s):

Emergency problems (e.g., gas leak, ambient CO levels that exceed 35 ppm) will be communicated clearly and immediately to the customer and appropriate solutions will be suggested

Objective(s):

Ensure system does not have fatal problems



 Before

Unsafe combustion appliances indicate need for repair or replacement



 After

In cases of replacement, ensure new appliance is safe and sized properly

2.0201.3a - Assessment



Assess existing combustion appliances for damage and replace when necessary



When a simple filter cleaning or replacement will help, make it happen



Ensure there is adequate make-up air -- combustion air inlet in closet

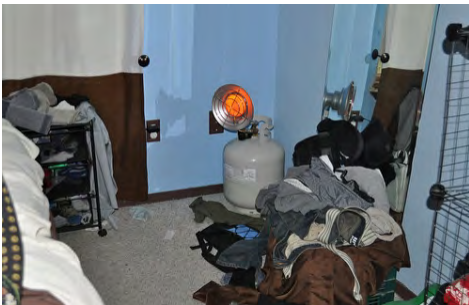

Stop the misuse of combustion appliances -- camp heater in bedroom



Keep occupant apprised of any health or safety concerns

2.0201.3b

Desired Outcome:

Accurate information about appliance safe operation is gathered

Specification(s):

Inspect and test for gas or oil leakage at connections of natural gas, propane piping, or oil systems

If leaks are found, immediate action will be taken to notify occupant to help ensure leaks are repaired

The report will specify repair for leaks and replacement for hazardous or damaged gas or oil connectors and pipes

Objective(s):

Detect fuel gas leaks

Determine and report need for repair



 Before

Fuel lines should be inspected for leakage



 After

If leaks are found, notify occupant immediately to facilitate repair

Tools:

1. Gas sniffer
2. Spray bottle

Materials:

1. Noncorrosive leak detection fluid

Paraphrased from 2012 IRC G2417: Leakage will be located using an *approved* combustible gas detector, a noncorrosive leak detection fluid or an equivalent nonflammable solution. Matches, candles, open flames or other methods that could provide a source of ignition cannot be used. Where leakage or other defects are located, the affected portion of the *piping system* will be repaired or replaced and retested.

2.0201.3b - Fuel leak detection



Inspect exterior gas and oil lines for leaks and damage



Inspect flex lines for damage, and check date on ring for pre-1973 hardware

2.0201.3c

Desired Outcome:

Accurate information about appliance safe operation is gathered

Specification(s):

The presence and operability of a draft regulator will be verified and tested

Combustion venting systems will be inspected for damage, leaks, disconnections, inadequate slope, and other safety hazards

Objective(s):

Determine if a regulator is present and working

Determine whether vent system is in good condition and installed properly



Unsafe

If ventilation system puts occupants at risk, it needs immediate attention

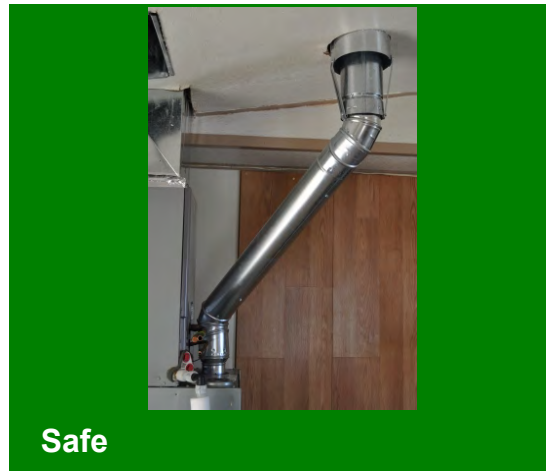

Safe

Properly vented appliances make a house healthier and more efficient

2.0201.3c - Venting



Determine if a draft regulator is installed and working



Inspect ventilation systems for damage



Inspect ventilation systems for disconnected pipes



Inspect ventilation systems for inadequate slope



Inspect for missing draft diverter

2.0201.3d

Desired Outcome:

Accurate information about appliance safe operation is gathered

Specification(s):

Baseline pressure will be measured in Combustion Appliance Zone (CAZ) with reference to outdoors

Objective(s):

Measure pressure difference between combustion zone and the outside under natural conditions



Natural conditions: wintertime set-up, air handler and exhaust fans off, all interior doors open

Tools:

1. Manometer

2.0201.3e

Desired Outcome:

Accurate information about appliance safe operation is gathered

Specification(s):

CAZ depressurization testing will be administered on all natural draft equipment

Objective(s):

Measure combined effect of mechanical system fans on combustion zone



Exhaust fans on, Check interior doors, Air handler on?

2.0201.3e - Depressurization test

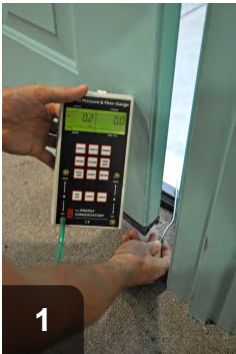

1 Place manometer reference hose to exterior of house



2 Attach test hose to be used in the interior of the house



3 Place test hose by combustion appliance

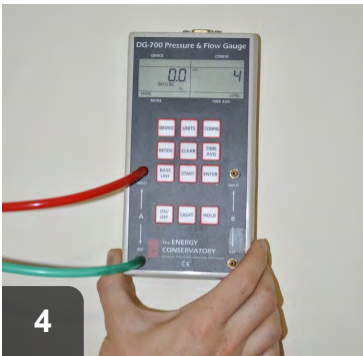

4 Take baseline reading

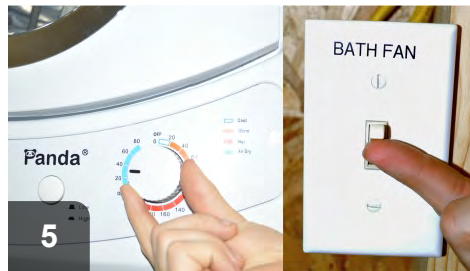

5 Turn on interior exhaust fans, including any clothes dryers

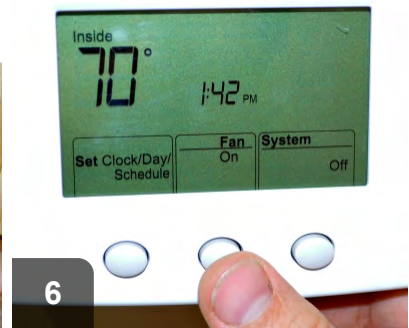

6 Is the air handler on?

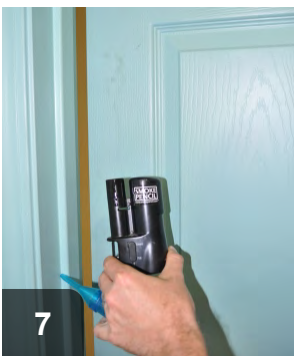

7 Check interior doors for pressure differential either using smoke pencil or hand



8 Manometer reading should be within allowable limit (See 2.0299.1a-i)



9 If reading is within allowable limit, all is well

2.0201.3f

Desired Outcome:

Accurate information about appliance safe operation is gathered

Specification(s):

Appliance spillage testing will be administered on natural draft appliances and shall not exceed 2 minutes

Objective(s):

Detect excessive spillage of combustion gases



Test natural draft furnace or water heater for spillage in excess of 2min

Tools:

1. Smoke pencil
2. Timer
3. Mirror



Test all sides of natural draft flues since draft may not be uniform

2.0201.3g

Desired Outcome:

Accurate information about appliance safe operation is gathered

Specification(s):

CO will be tested for in undiluted flue gases of combustion appliances

For CO levels exceeding 100 ppm as measured or 200 ppm air-free measurement, service will be provided to reduce CO to below these levels (unless CO measurement is within manufacturer specifications)

If the outlet of the exhaust is accessible, include a CO test on all sealed- combustion and power-vented appliances (without atmospheric chimneys)

Objective(s):

Measure CO and report excessive levels



Unsafe

CO levels cannot exceed 100ppm as measured, unless to manufacturer specs



Best Practice

Test CO levels in undiluted flue gases and exhaust outlets, when accessible

Tools:

1. Combustion analyzer with probe
2. Drill

2.0201.3g - Carbon monoxide (CO) test in appliance vent



CO levels cannot exceed 100ppm, or 200ppm air-free CO



Test undiluted flue gases in induced-draft furnaces



Test undiluted flue gases in natural draft water heaters



Test accessible exhaust outlets for power-vented appliances



Test accessible exhaust outlets for direct-vent appliances

2.0201.3h

Desired Outcome:

Accurate information about appliance safe operation is gathered

Specification(s):

Final combustion testing will be conducted at project completion to ensure compliance with the above specifications

Objective(s):

Ensure safe operation of combustion appliance within the whole house system after any repair project



 Before

Damaged and unsafe combustion appliances should be replaced



 After

Before leaving retrofit, test new combustion appliances to verify they are working safely

2.0201.3h - Final test out



Complete spillage test using chemical smoke pencil



Complete carbon monoxide testing using a CO detector



Complete draft test using a manometer

2.0202.1a

Desired Outcome:

Elimination of combustion byproducts

Specification(s):

With the occupant's permission, unvented heaters will be removed, except when used as a secondary heat source and when it can be confirmed that the unit is listed to ANSI Z21.11.2

Units that are not being operated in compliance with ANSI Z21.11.2 should be removed before the retrofit but may remain until a replacement heating system is in place

Failure to remove unvented space heaters serving as primary heat sources has the potential to create hazardous conditions, and thus any further weatherization services will be reevaluated in the context of potential indoor air quality risks

Objective(s):

Eliminate sources of combustion byproduct within a living space



Before

Unvented space heaters should be removed with the occupants' permission



After

Unvented space heaters can be replaced with properly vented space heaters

2.0202.1a - Removal



Secure permission to remove unvented space heaters from occupants



Ensure new combustion appliances are vented properly

2.0202.1b

Desired Outcome:

Elimination of combustion byproducts

Specification(s):

Occupant will be educated on potential hazards of unvented combustion appliances (primary or secondary) within a living space

Objective(s):

Inform occupant about possible hazards associated with combustion byproducts and moisture



Unsafe

Unvented space heaters in homes are hazardous to occupants



Best Practice

Clearly communicate the hazards to the occupant in order to inform their decision to remove the appliance

2.0202.1b - Occupant education



Unvented space heaters significantly increase the risk of house fires



Unvented combustion gases cause a hazard to all occupants



Unvented space heaters can create moisture issues in homes, leading to black mold

2.0203.4a

Desired Outcome:

Sufficient air provided in the Combustion Appliance Zone (CAZ)

Specification(s):

The required volume of indoor air will be determined in accordance with Section G2407.5.1 or G2407.5.2 and authority having jurisdiction, except where the air infiltration rate is known to be less than 0.40 air changes per hour (ACH), at which time Section G2407.5.2 will be used

Objective(s):

Determine if existing conditions meet the combustion air calculation

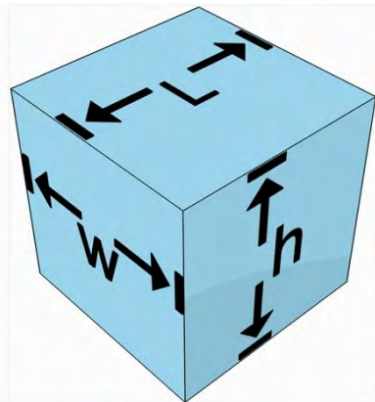

Best Practice

G2407.5.1 (304.5.1) Standard method. The minimum required volume shall be 50 cubic feet per 1,000 *Btu/h* (4.8 m³/kW).

G2407.5.2 (304.5.2) Known air-infiltration-rate method. Where the air infiltration rate of a structure is known, the minimum required volume shall be determined as follows: For purposes of this calculation, an infiltration rate greater than 0.60 ACH shall not be used in Equations 24-1.

For *appliances* other than fan assisted, calculate volume using Equation 24-1.

Required Volume(natural draft) ≥ (21ft³/ACHn)(Input(other)/1,000BTU/hr)*

Input(other) = All appliances other than fan assisted (input in Btu/h).

ACHn = Air change per hour under natural conditions

Standard: 100,000 BTUH Furnace Input 100,000 x .05 = 5,000ft³ or 100,000/1000 = 100. 100 x 50 = 5,000ft³

Known infiltration rate method(assuming ACHn is .50 in this example): $((21\text{ft}^3/.50) * (100,000 / 1,000\text{BTU/hr})) = 4,200\text{ft}^3$

2.0203.4a - Required combustion air



Measure the CAZ width.



Measure the CAZ length.



Measure the CAZ height.

2.0203.4b

Desired Outcome:

Sufficient air provided in the Combustion Appliance Zone (CAZ)

Specification(s):

Additional combustion air will be provided in accordance with 2012 IRC G2407 and authority having jurisdiction

Objective(s):

Ensure adequate combustion air for operation of the appliance



Combustion appliances in a confined space

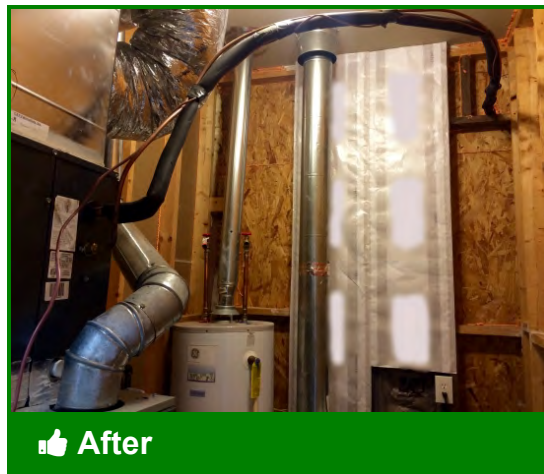

Additional combustion air supplied from high/low vents

Tools:

1. Drywall saw
2. Drill
3. Tin snips
4. Tape measure
5. Wire cutters

Materials:

1. Metal ducts
2. 1/4" galvanized hardware cloth mesh
3. Galvanized straps or L-brackets to secure high/low vents
4. Screws
5. Louvered grilles (optional)
6. Louvered doors (optional)

Combustion appliances require 50 cubic feet of volume for every 1,000 Btuh input. If this is not available, provide makeup air in accordance with the IRC G.2407 or local code.

When high/low vents are used, use two metal ducts each having 1 in² of cross-sectional area for every 4,000 Btuh input. Extend each into the attic above the insulation level, and use 1/4" galvanized hardware cloth mesh on top to screen out insects and vermin. Terminate one vent within 12" of the ceiling, and one vent within 12" of the floor. The vents may be concentric (one inside the other) to

save space, so long as the difference between the area of the larger and smaller vents is equal to or greater than the 1 in²/4,000 Btuh requirement.

If using a single large opening in the ceiling, make the opening total 1 in² per 3,000 Btuh input.

If high/low vents extend horizontally through a CAZ wall, use vents with 1 in² of area per 2,000 Btuh of input.

Louvered grilles or doors may be used to connect the CAZ to larger sections of the home to achieve the required volume, but be aware that using this approach has higher potential for creating a carbon monoxide pathway into the home than does creating a sealed CAZ with high/low vents.

2.0203.4b - Additional combustion air (if action is required)



1
Select vent sizes based on the total input Btus in the CAZ. Concentric vents are shown

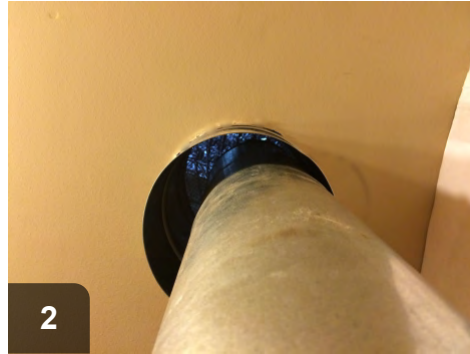

2
Cut hole in ceiling and mount high/low vents to framing



3
Fasten 1/4" galvanized hardware cloth over high/low vent openings



4
Complete installation by adding supports and fasteners as required for stability and durability



5
Terminate the low vent within 12" of the floor. This one is mounted inside a section of larger diameter metal duct

2.0203.4c

Desired Outcome:

Sufficient air provided in the Combustion Appliance Zone (CAZ)

Specification(s):

If a combustion appliance spillage exceeds 2 minutes during pressure testing, specify measures to mitigate

Objective(s):

Ensure appliance is not spilling longer than 2 minutes



Natural draft appliances should be tested for spillage



Spillage should not exceed 2 minutes, if present

Tools:

1. Smoke pencil
2. Stopwatch or timer

2.0203.4c - Spillage testing



Inspect appliance for evidence of damage or unsafe operation before testing



Fire up appliance in order to test



Test for spillage--should not exceed 2min. If 2min are exceeded, mitigate.

2.0203.4d

Desired Outcome:

Sufficient air provided in the Combustion Appliance Zone (CAZ)

Specification(s):

All homes will have a functioning CO alarm

If CO levels in interior living spaces exceed outdoor levels, investigate potential sources and take appropriate action to reduce them (e.g., have a qualified professional tune, repair, or replace improperly operating combustion appliances; apply weatherstripping; or conduct air sealing between the garage or crawl space and the home)

Objective(s):

Ensure occupant health and safety

Ensure indoor CO levels do not exceed outdoor CO levels



Best Practice

If CO levels are elevated, locate source of CO and mitigate leakage



Best Practice

Carbon monoxide alarms should be installed in all homes

Tools:

1. Combustion analyzer with probe
2. Personal CO monitor
3. Drill or hammer

Materials:

1. CO alarm, for installation if necessary
2. Mounting hardware

2.0203.4d - Occupant health and safety



1

Check CO levels both inside and outside home



2

All homes should have CO monitors installed. If levels are elevated, look for the source



3

Test combustion appliances to ensure proper operation



4

When cause of elevated CO levels has been located, take steps to correct



5

Appliance maintenance and air sealing are two ways to remediate CO leakage

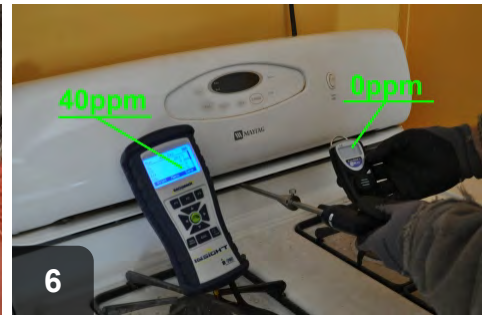

6

After mitigation, verify that CO has returned to safe levels



7

Verify safe levels on more than one instrument and in more than one location

2.0203.4e

Desired Outcome:

Sufficient air provided in the Combustion Appliance Zone (CAZ)

Specification(s):

Occupants will be educated on the operation and maintenance of the CO alarm

Completed work on combustion appliances and recommended maintenance will be reviewed with occupant

Occupant will be provided information regarding the health effects and risks of high CO concentrations

Objective(s):

Ensure occupant can operate and maintain installations

Inform occupant regarding possible CO hazards



 Before

Occupants may be unfamiliar with CO alarms and proper operation and maintenance



 After

Clear and effective communication with occupants can ensure the proper operation of CO alarms

2.0203.4e - Occupant education



All homes should have CO alarms installed, whether hardwired or battery-operated



Discuss CO risks and proper operation of alarm with occupant



Explain routine maintenance of alarm

2.0203.5a

Desired Outcome:

Flue gasses successfully removed from the house

Specification(s):

If a combustion appliance spillage exceeds 2 minutes during pressure testing, specify measures to mitigate

Objective(s):

Ensure appliance is not spilling longer than 2 minutes



Orphaned water heaters have oversized flues after a furnace is removed

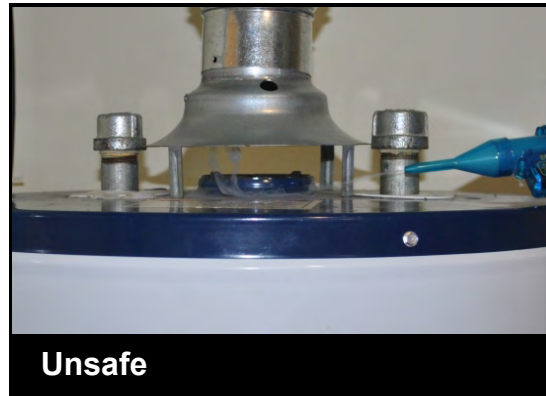

Spillage should not exceed 2 minutes, if present

Tools:

1. Smoke pencil
2. Mirror
3. Stopwatch, timer, or watch with second hand

2.0203.5b

Desired Outcome:

Flue gasses successfully removed from the house

Specification(s):

If a combustion appliance spillage exceeds 2 minutes during pressure testing, specify measures to mitigate

Objective(s):

Ensure appliance is not spilling longer than 2 minutes



Before

If spillage continues to exceed 2 min, additional repairs are required



After

The elimination of the oversized chimney should prevent spillage

Tools:

1. Smoke pencil

2.0203.5b - Retesting spillage

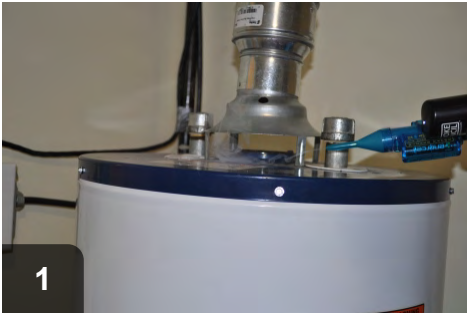

Retest for spillage. If spillage remains, more repair is needed.



Repipe the flue to eliminate the oversized chimney

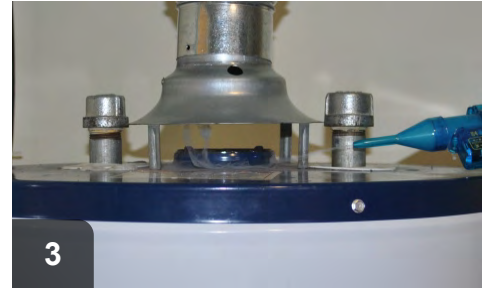

When repairs have been completed, no spillage should occur

2.0203.5c

Desired Outcome:

Flue gasses successfully removed from the house

Specification(s):

The minimum required volume will be 50 cubic feet per 1,000 Btu/h in accordance with 2012 IRC G2407.5.1 or local authority having jurisdiction

Objective(s):

Determine if existing conditions meet the combustion air calculation

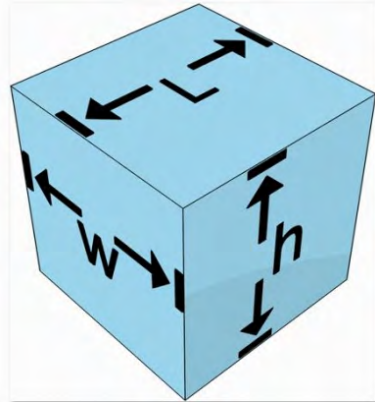

Best Practice

Compare measured volume with required volume. If measured volume is lower than required, combustion air is needed.

G2407.5.1 (304.5.1) Standard method. The minimum required volume shall be 50 cubic feet per 1,000 *Btu/h* (4.8 m³/kW).

G2407.5.2 (304.5.2) Known air-infiltration-rate method. Where the air infiltration rate of a structure is known, the minimum required volume shall be determined as follows: For purposes of this calculation, an infiltration rate greater than 0.60 ACH shall not be used in Equations 24-1.

For *appliances* other than fan assisted, calculate volume using Equation 24-1.

Required Volume(natural draft) $\geq (21\text{ft}^3/\text{ACHn}) * (\text{Input}(\text{other})/1,000\text{BTU/hr})$

Input(other) = All appliances other than fan assisted (input in Btu/h).

ACHn = Air change per hour under natural conditions

Standard: 100,000 BTUH Furnace Input $100,000 \times .05 = 5,000\text{ft}^3$ or $100,000/1000 = 100$. $100 \times 50 = 5,000\text{ft}^3$

Known infiltration rate method (assuming ACHn is .50 in this example): $((21\text{ft}^3/.50) \times (100,000/1,000\text{BTU/hr})) = 4,200\text{ft}^3$

2.0203.5c - Required combustion air



1 Measure the CAZ width.



2 Measure the CAZ length.



3 Measure the CAZ height.

2.0203.5d

Desired Outcome:

Flue gasses successfully removed from the house

Specification(s):

Additional combustion air will be provided in accordance with 2012 IRC G2407 or local authority having jurisdiction

Objective(s):

Ensure adequate combustion air for operation of the appliance



Combustion appliances in a confined space



Additional combustion air supplied from high/low vents

Tools:

1. Drywall saw
2. Drill
3. Tin snips
4. Tape measure

Materials:

1. Metal ducts
2. 1/4" galvanized hardware cloth mesh
3. Galvanized straps or L-brackets to secure high/low vents
4. Screws
5. Louvered grilles
6. Louvered doors

Combustion appliances require 50 cubic feet of volume for every 1,000 Btuh input. If this is not available, provide makeup air in accordance with the IRC G.2407 or local code

2.0203.5d - Additional combustion air (if action is required)



1
Select vent sizes based on the total input Btus in the CAZ. Concentric vents are shown



2
Cut hole in ceiling and mount high/low vents to framing



3
Fasten 1/4" galvanized hardware cloth over high/low vent openings



4
Complete installation by adding supports and fasteners as required for stability and durability



5
Terminate low vent within 12" of the floor. This one is fastened to a section of larger diameter duct for stability

2.0203.5e

Desired Outcome:

Flue gasses successfully removed from the house

Specification(s):

All homes will have a functioning CO alarm (EPA offers expanded actions)

If CO levels in interior living spaces exceed outdoor levels, investigate potential sources and take appropriate action to reduce them (e.g., have a qualified professional tune, repair, or replace improperly operating combustion appliances; apply weatherstripping; or conduct air sealing between the garage or crawl space and the home)

Objective(s):

Ensure occupant health and safety

Ensure indoor CO levels do not exceed outdoor CO levels



Carbon monoxide alarms should be installed in all homes



If CO levels are elevated, locate source of CO and mitigate leakage

Tools:

1. Combustion analyzer with probe
2. Personal CO monitor
3. Drill or hammer

Materials:

1. CO alarm, for installation if necessary
2. Mounting hardware

2.0203.5e - Occupant health and safety

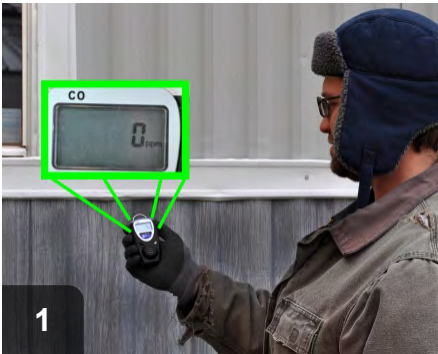

1 Check CO levels both inside and outside home



2 All homes should have CO monitors installed. If levels are elevated, look for the source



3 Test combustion appliances to ensure proper operation



4 In older mobile homes, the water heater closet may be accessed from the exterior



5 When cause of elevated CO levels has been located, take steps to correct



6 Appliance maintenance and air sealing are two ways to remediate CO leakage



7 After mitigation, verify that CO has returned to safe levels



8 Verify safe levels on more than one instrument and in more than one location

2.0203.5f

Desired Outcome:

Flue gasses successfully removed from the house

Specification(s):

Occupants will be educated on the operation and maintenance of the CO alarm

Completed work on combustion appliances and recommended maintenance will be reviewed with occupant

Occupant will be provided information regarding the health effects and risks of high CO concentrations

Objective(s):

Ensure occupant can operate and maintain installations

Inform occupant regarding possible CO hazards



Before

Occupants may be unfamiliar with CO alarms and proper operation and maintenance



After

Clear and effective communication with occupants can ensure the proper operation of CO alarms

2.0203.5f - Occupant education



All homes should have CO alarms installed, whether hardwired or battery-operated



Discuss CO risks and proper operation of alarm with occupant



Explain routine maintenance of alarm

2.0203.6a

Desired Outcome:

Buildup of flue gasses prevented with proper drafting

Specification(s):

The presence of an operable draft regulator will be verified

Combustion venting systems will be inspected for damage, leaks, disconnections, and other safety hazards

Objective(s):

Determine if a regulator is present and working and if vent system is in good condition and installed properly

2.0203.6b

Desired Outcome:

Buildup of flue gasses prevented with proper drafting

Specification(s):

A draft regulator will be installed if necessary

Manufacturer specifications for installation will be followed (e.g., size, type, location)

Objective(s):

Install regulator in accordance with manufacturer specifications

2.0203.6c

Desired Outcome:

Buildup of flue gasses prevented with proper drafting

Specification(s):

If a combustion appliance spillage exceeds 2 minutes during pressure testing, specify measures to mitigate

Objective(s):

Ensure appliance is not spilling longer than 2 minutes

2.0203.6d

Desired Outcome:

Buildup of flue gasses prevented with proper drafting

Specification(s):

All homes will have a functioning CO alarm; EPA offers expanded actions

If CO levels in interior living spaces exceed outdoor levels, potential sources will be investigated and appropriate action taken to reduce them (e.g., have a qualified professional tune, repair, or replace improperly operating combustion appliances; apply weatherstripping; conduct air sealing between the garage or crawl space and the home)

Objective(s):

Ensure occupant health and safety

Ensure indoor CO levels do not exceed outdoor CO levels



Best Practice

If CO levels are elevated, locate source of CO and mitigate leakage



Best Practice

Carbon monoxide alarms should be installed in all homes

Tools:

1. Combustion analyzer with probe
2. Personal CO monitor
3. Drill or hammer

Materials:

1. CO alarm, for installation if necessary
2. Mounting hardware

2.0203.6d - Occupant health and safety

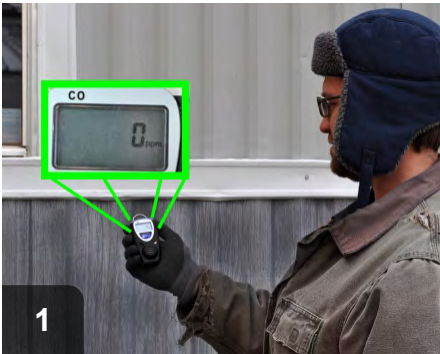

1 Check CO levels both inside and outside home



2 All homes should have CO monitors installed. If levels are elevated, look for the source



3 Test combustion appliances to ensure proper operation



4 When cause of elevated CO levels has been located, take steps to correct



5 Appliance maintenance and air sealing are two ways to remediate CO leakage



6 After mitigation, verify that CO has returned to safe levels



7 Verify safe levels on more than one instrument and in more than one location

2.0203.6e

Desired Outcome:

Buildup of flue gasses prevented with proper drafting

Specification(s):

Occupants will be educated on the operation and maintenance of the CO alarm

Completed work on combustion appliances and recommended maintenance will be reviewed with occupant

Occupant will be provided information regarding the health effects and risks of high CO concentrations

Objective(s):

Ensure occupant can operate and maintain installations

Inform occupant regarding possible CO hazards



 Before

Occupants may be unfamiliar with CO alarms and proper operation and maintenance



 After

Clear and effective communication with occupants can ensure the proper operation of CO alarms

2.0203.6e - Occupant education



All homes should have CO alarms installed, whether hardwired or battery-operated



Discuss CO risks and proper operation of alarm with occupant



Explain routine maintenance of alarm

2.0204.1a

Desired Outcome:

Isolate combustion water heater closet from conditioned space

Specification(s):

Installer prework assessment will be conducted to determine:

- Combustion safety
- Proper venting
- Structural integrity
- Roof leaks
- Insect infestation
- Accessibility
- Number, type, size, and location of penetrations

Objective(s):

Ensure combustion appliance is functioning safely

Ensure work space is safe and ready for air sealing

Verify scope of work

2.0204.1b

Desired Outcome:

Isolate combustion water heater closet from conditioned space

Specification(s):

When the water heater closet contains a heater that is not sealed combustion or power vented, the closet will be isolated/separated from the rest of the home through air sealing with fire-rated materials, if feasible

Avoiding frozen pipes must be considered without creating an additional utility burden (e.g., heat tape)

Objective(s):

Prevent combustion gases from entering living area and minimize extension of interior pressures caused by exhaust fan, dryers, and interior door closure into the water heater closet

2.0204.1c

Desired Outcome:

Isolate combustion water heater closet from conditioned space

Specification(s):

Only noncombustible materials will be used in contact with chimneys, vents, and flues

Objective(s):

Prevent a fire hazard



Best Practice

When sealing around combustion flue penetrations, use appropriate materials

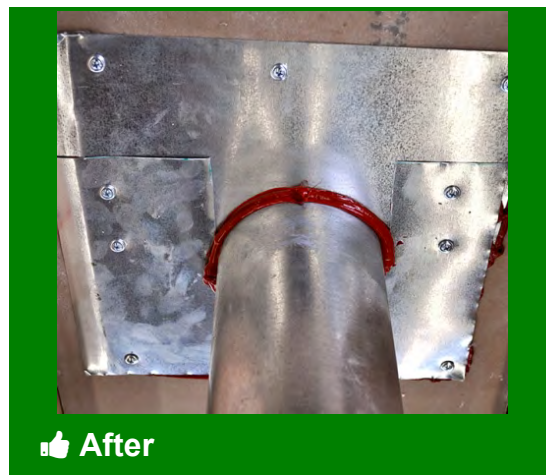

After

26-gauge steel sheeting and high temp caulk should be used to seal around flue

Tools:

1. Caulk gun
2. Metal snips
3. Drill

Materials:

1. High-temperature caulk
2. 26-gauge steel sheeting
3. Fasteners

2.0204.1d

Desired Outcome:

Isolate combustion water heater closet from conditioned space

Specification(s):

Blower door assisted zonal pressure diagnostics will be used to verify isolation has been achieved

Objective(s):

Prevent combustion gases from entering living area



 Before

The reading is closer to 0, indicating strong connection to the inside.



 After

The reading is closer to 50, indicating strong connection to the outside.

Tools:

1. blower door assembly
2. manometer
3. 1/4" hose
4. steel tube or probe
5. drill

2.0204.1d - Post-work testing/verification



Depressurize the house to 50 pascals.



Close the CAZ door or otherwise gain access to the CAZ.



Reading is closer to 50 pascals indicating combustion closet is connected to the outside.

2.0299.1a

Desired Outcome:

Ensure appliances meet manufacturer's certified negative pressure tolerance rating

Specification(s):

Manufacturer's certified negative pressure tolerance rating:

- Limit -2 pascals

Objective(s):

Ensure appliances meet manufacturer's certified negative pressure tolerance rating



A natural draft water heater with draft hood highlighted

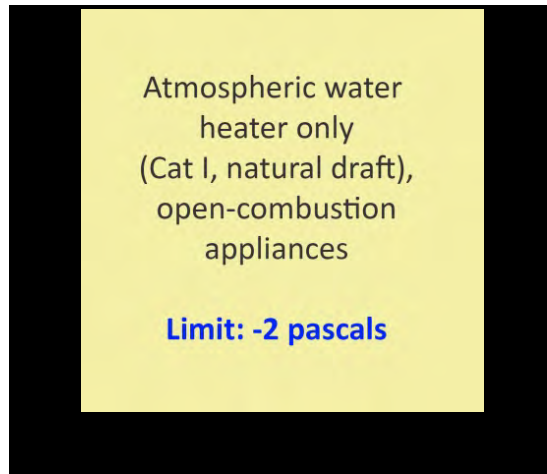

Tools:

1. Manometer

2.0299.1b

Desired Outcome:

Ensure appliances meet manufacturer's certified negative pressure tolerance rating

Specification(s):

Manufacturer's certified negative pressure tolerance rating:

- Limit -3 pascals

Objective(s):

Ensure appliances meet manufacturer's certified negative pressure tolerance rating

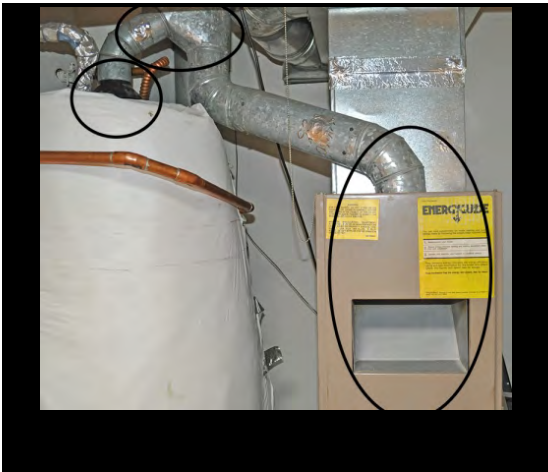

Natural draft water heater and natural draft furnace with common vent

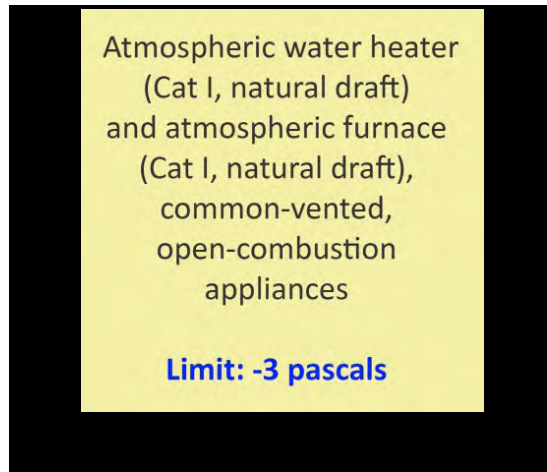

Tools:

1. Manometer

2.0299.1b - Atmospheric water heater (Category I, natural draft) and atmospheric furnace (Category I, natural draft), common-vented, open-combustion appliances



Common vent of natural draft appliances highlighted

2.0299.1c

Desired Outcome:

Ensure appliances meet manufacturer's certified negative pressure tolerance rating

Specification(s):

Manufacturer's certified negative pressure tolerance rating:

- Limit -5 pascals

Objective(s):

Ensure appliances meet manufacturer's certified negative pressure tolerance rating



Category I 70% efficiency gas furnace with draft hood highlighted

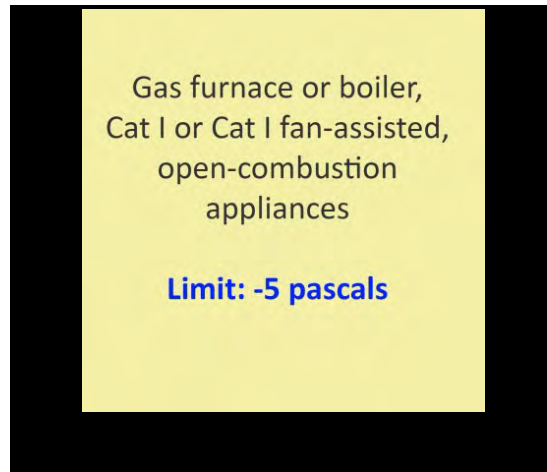

Tools:

1. Manometer

2.0299.1c - Gas furnace or boiler, Category I or Category I fan-assisted, open-combustion appliances



Cat I 80% efficiency furnace

2.0299.1d

Desired Outcome:

Ensure appliances meet manufacturer's certified negative pressure tolerance rating

Specification(s):

Manufacturer's certified negative pressure tolerance rating:

- Limit -5 pascals

Objective(s):

Ensure appliances meet manufacturer's certified negative pressure tolerance rating



Oil burner

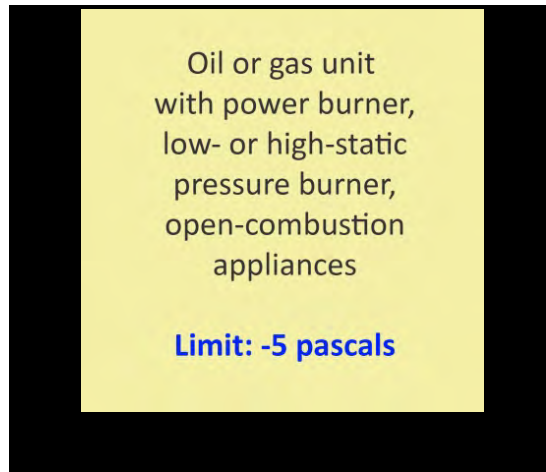

Tools:

1. Manometer

2.0299.1e

Desired Outcome:

Ensure appliances meet manufacturer's certified negative pressure tolerance rating

Specification(s):

Manufacturer's certified negative pressure tolerance rating:

- Limit -7 pascals

Objective(s):

Ensure appliances meet manufacturer's certified negative pressure tolerance rating



Wood-burning stove

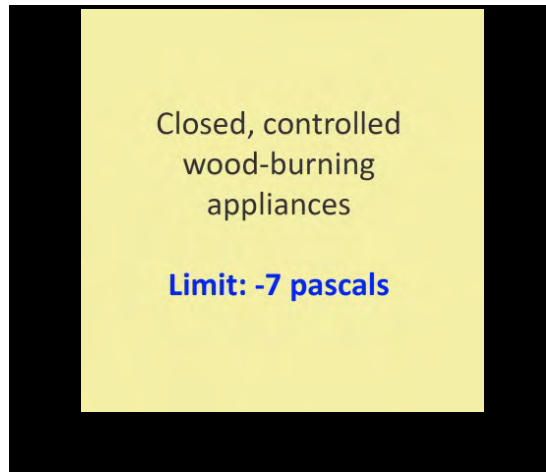

Tools:

1. Manometer

2.0299.1f

Desired Outcome:

Ensure appliances meet manufacturer's certified negative pressure tolerance rating

Specification(s):

Manufacturer's certified negative pressure tolerance rating:

- Limit -15 pascals

Objective(s):

Ensure appliances meet manufacturer's certified negative pressure tolerance rating



Induced draft furnace

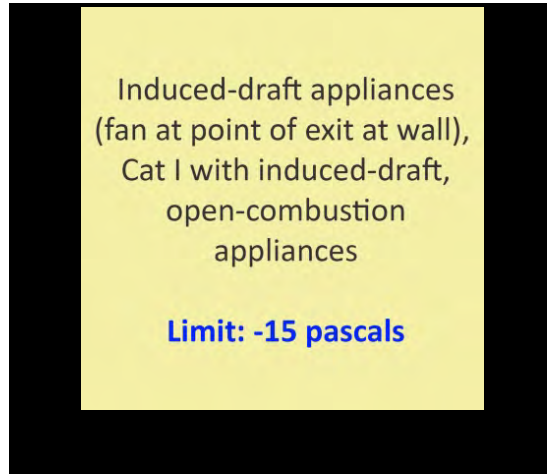

Tools:

1. Manometer

2.0299.1g

Desired Outcome:

Ensure appliances meet manufacturer's certified negative pressure tolerance rating

Specification(s):

Manufacturer's certified negative pressure tolerance rating:

- Limit -15 pascals

Objective(s):

Ensure appliances meet manufacturer's certified negative pressure tolerance rating



Pellet stove

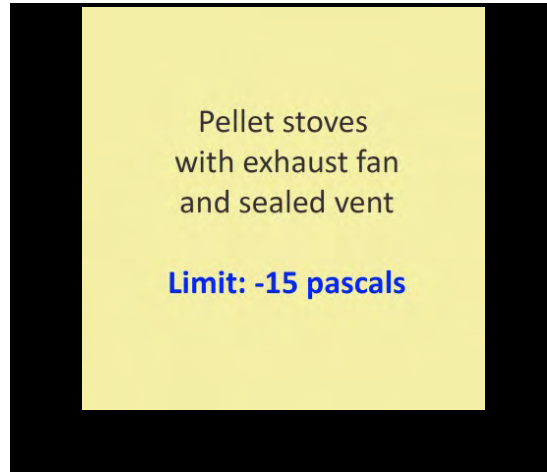

Tools:

1. Manometer

2.0299.1h

Desired Outcome:

Ensure appliances meet manufacturer's certified negative pressure tolerance rating

Specification(s):

Manufacturer's certified negative pressure tolerance rating:

- Limit -15 pascals

Objective(s):

Ensure appliances meet manufacturer's certified negative pressure tolerance rating

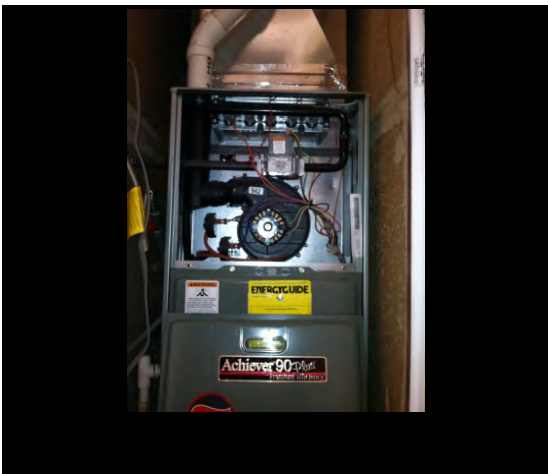

Single-pipe 90% efficiency furnace with forced draft

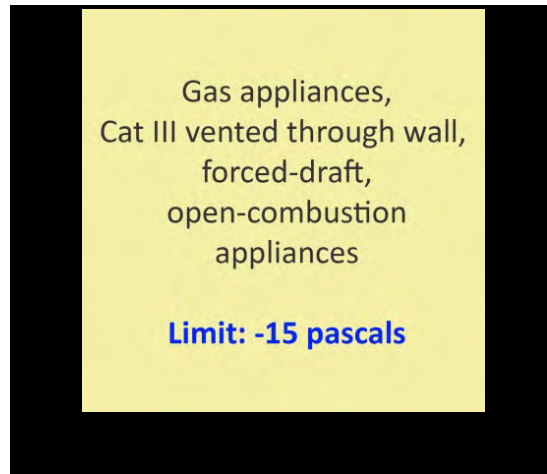

Tools:

1. Manometer

2.0299.1h - Gas appliances, Category III vented through the wall, forced draft, open-combustion appliances



Power-vented water heater

2.0299.1i

Desired Outcome:

Ensure appliances meet manufacturer's certified negative pressure tolerance rating

Specification(s):

Manufacturer's certified negative pressure tolerance rating:

- Limit -25 pascals

Objective(s):

Ensure appliances meet manufacturer's certified negative pressure tolerance rating



Forced draft appliance with sealed combustion

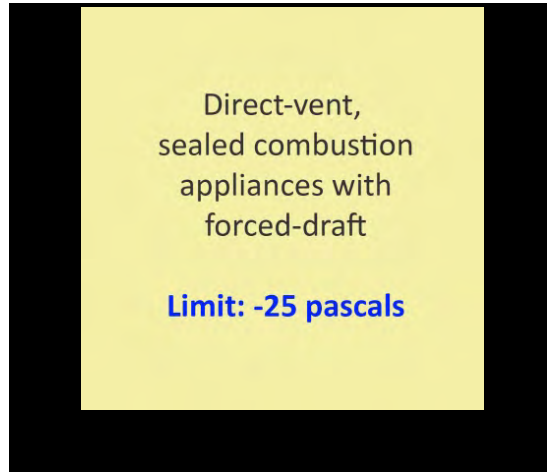

Tools:

1. Manometer

2.0299.1i - Direct-vent, sealed combustion appliances with forced draft



Two-pipe 90% efficiency furnace



Direct-vent Rinnai



Exterior vent for Rinnai

2.0301.1a

Desired Outcome:

Properly installed smoke alarms

Specification(s):

Smoke alarms will be listed and labeled in accordance with UL 217 and installed (hardwired) in accordance with the 2012 IRC or as required by the authority having jurisdiction

Installation will be accomplished by a licensed electrician when required by the authority having jurisdiction

Objective(s):

Ensure proper installation



Hard-wired smoke alarm mount with alarm missing



Hard-wired smoke alarm mount with alarm replaced

2.0301.1b

Desired Outcome:

Properly installed smoke alarms

Specification(s):

Battery-operated alarms will be installed in accordance with the 2012 IRC and manufacturer specifications

Objective(s):

Ensure proper installation



All homes should have UL-217 rated smoke alarms

Paraphrased from 2012 IRC R314: Smoke alarms will be permitted to be battery operated when installed in buildings without commercial power or when alterations or repairs do not result in the removal of interior wall or ceiling finishes exposing the structure to provide access for hard-wiring, unless there is an attic, crawl space, or basement available with could provide access.

2.0301.1b - Smoke alarm (battery operated)



Ceiling mounted smoke alarms can be battery-operated



Wall mounted smoke alarms must be mounted within 12 inches of the ceiling and per manufacturer's specifications

2.0301.2a

Desired Outcome:

Properly installed CO alarms or monitors

Specification(s):

Hardwired CO detection or warning equipment will be installed in accordance with the ASHRAE 62.2 or as required by the authority having jurisdiction

Installation will be accomplished by a licensed electrician when required by the authority having jurisdiction

Objective(s):

Ensure proper installation



All homes should have a carbon monoxide detector installed, whether hardwired or battery operated

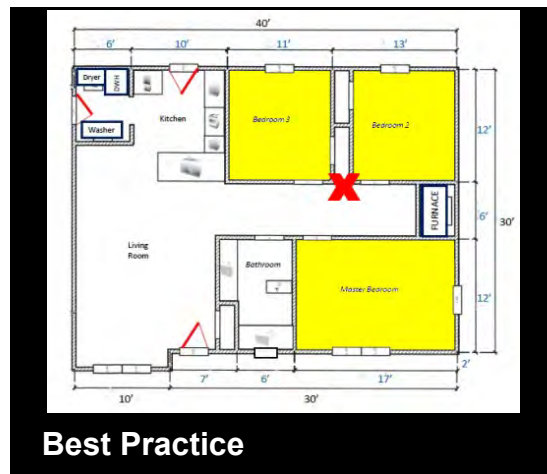

Alarms should be mounted in sleeping areas--such as the one marked in red

Tools:

1. Hammer

Materials:

1. Nails

Per WPN 14-01, full compliance with ASHRAE 62.2.2013 and NFPA 720 is required.

2.0301.2a - CO detection and warning equipment (hardwired)



Mount alarm to wall close to bedrooms

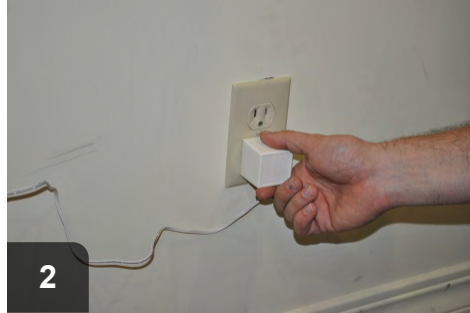

Plug alarm into outlet. In addition, cord can be stapled into place

2.0301.2b

Desired Outcome:

Properly installed CO alarms or monitors

Specification(s):

Battery-operated CO detection or warning equipment will be installed in accordance with the ASHRAE 62.2 and manufacturer specifications as required by the authority having jurisdiction

Objective(s):

Ensure proper installation



Houses should have carbon monoxide monitors installed near sleeping areas



Battery operated CO alarms should be UL-2075 or UL-2034 compliant

Paraphrased from 2012 IRC R315: An approved CO alarm will be installed outside of each separate sleeping area in the immediate vicinity of the bedrooms in all dwelling units. CO detectors will comply with UL 2075. Single-station CO alarms will comply with UL 2034 and will be installed in accordance with this code and the manufacturer's installation instructions. Per WPN 14-01, full compliance with ASHRAE 62.2.2013 and NFPA 720 is required.

2.0401.1a

Desired Outcome:

Ensure durability of repairs and reduce potential for occupant exposure to mold and other moisture-related hazards

Specification(s):

Roof leaks will be repaired before performing attic air sealing or insulation

Moisture sources in the house that can generate moisture into the attic will be identified and removed or reduced

Water-resistant sealants and/or closed cell foams (use a minimum of 2" to reach water barrier requirement) will be used in all attic sealing details in cold climates

Plastic, foil, or any other Class 1 vapor barrier will not be used in hot humid climates

In marine climates, vapor permeable materials will be used to block and seal penetrations in attic

Objective(s):

Ensure durability of repairs

Reduce potential for occupant exposure to mold and other moisture-related hazards

Prevent moisture from communicating from within the conditioned space into unconditioned attic space when economically feasible

Increase durability of seal

Avoid moisture-related damage to the home

2.0401.1b

Desired Outcome:

Ensure durability of repairs and reduce potential for occupant exposure to mold and other moisture-related hazards

Specification(s):

Exposed earth will be covered with a continuous, durable, sealed Class 1 vapor retarder a minimum of 6 mils in thickness

Plastic, foil, or any other Class 1 vapor barrier/retarder will not be used in hot-humid climates

All accessible penetrations between the crawl space or basement and outside will be sealed

Holes between the crawl space or basement and the living space will be sealed

Objective(s):

Ensure durability of repairs

Reduce potential for occupant exposure to mold and other moisture-related hazards

2.0401.1c

Desired Outcome:

Ensure durability of repairs and reduce potential for occupant exposure to mold and other moisture-related hazards

Specification(s):

Moisture sources in the home will be identified and removed or reduced

Local ventilation will be installed where appropriate (e.g., baths, kitchens) and vented to outside according to ASHRAE 62.2-2010

Unvented combustion appliances that are not listed to ANSI Z21.11.2 will be removed

Objective(s):

Ensure durability of repairs

Reduce potential for occupant exposure to mold and other moisture-related hazards

2.0401.1d

Desired Outcome:

Ensure durability of repairs and reduce potential for occupant exposure to mold and other moisture-related hazards

Specification(s):

Before air sealing basement or crawl space walls near wet areas, surface water pooling near the foundation will be addressed by:

- Repairing, modifying, or replacing gutters and downspouts
- Grading and subsurface drainage at critical locations (e.g., localized drain and grading beneath valleys) in accordance with EPA) Indoor airPLUS Construction Specifications Section 1.1
- Possible mitigation by waterproofing or installing draining plane with construction adhesive

Objective(s):

Reduce potential for occupant exposure to mold and other moisture-related hazards

2.0402.2a

Desired Outcome:

Move water away from home

Specification(s):

Installer prework assessment will be conducted to determine:

- Standing water
- Positive grade/drainage
- Conditions of gutter system
- Vegetation/shrubbery
- Settling of home
- Leveling of home

Ensure no organic material is under the supports, including topsoil and roots

Objective(s):

Verify scope of work

Ensure that work space is ready for work

2.0402.2b

Desired Outcome:

Move water away from home

Specification(s):

Ground will be properly graded to provide positive slope (1" per foot) away from home

Gutter and downspouts will be installed or repaired

Vegetation within 36" and encroaching on home will be cleared or trimmed if occupant approves

Home will be leveled to compensate for settling or improper installation

Objective(s):

Ensure positive drainage

Maintain ventilation around home

2.0402.2c

Desired Outcome:

Move water away from home

Specification(s):

Occupant will be educated on the benefit of trees and shrubs to reduce heat gain and provide wind breaks in high wind locations

Occupant will be educated on the need to maintain positive drainage (e.g., gutters, down spouts, grading) and maintain ventilation

Objective(s):

Maintain durability

Ensure water is moved down and away from home

2.0403.4a

Desired Outcome:

Durable, effective ground moisture barrier that provides ongoing access and minimizes ground vapor

Specification(s):

If existing conditions of the ground and skirting mandates, a moisture barrier that covers the crawl space ground will be installed with allowances for structural supports (piers) and accessibility

Objective(s):

Reduce ground moisture entering crawl space



Manufactured home crawlspace with incomplete ground vapor barrier



Manufactured home crawlspace with complete ground vapor barrier

Tools:

1. Utility knife
2. Hammer or mallet
3. Scissors

Materials:

1. Polyethylene vapor barrier, 4-mil thickness or greater
2. Waterproof tape
3. Polyurethane caulking or construction adhesive
4. Landscape staples

Aim for complete coverage. If access to the entire crawlspace is impossible, cover all accessible areas. Overlap seams in vapor barrier by at least twelve inches, and seal them with waterproof tape and/or polyurethane caulk or adhesive. Wrap and cover support piers at least twelve inches high.

2.0403.4a - Coverage



1 Remove skirting as needed for access to crawlspace



2 Measure, cut, and spread vapor barrier material after removing debris over 1/2" in size. Notch around obstructions



3 Wrap piers and columns at least six inches high. Use additional material to cover any gaps and holes in vapor barrier



4 Secure vapor barrier to ground with corrosion-resistant landscape staples, or weigh it down with ballast



5 Remove tools and excess material



6 Reinstall skirting

2.0403.4b

Desired Outcome:

Durable, effective ground moisture barrier that provides ongoing access and minimizes ground vapor

Specification(s):

A ground moisture barrier with a rating of no more than 0.1 perm will be used

A ground moisture barrier will be used that meets tear and puncture resistance standard ASTM E1745

Homeowner will be advised that all plastic is biodegradable and will have a life span much shorter than the home (5 years), and it will need replacing to remain effective

Objective(s):

Ensure crawl space is accessible for service and maintenance without damaging the integrity of the ground moisture barrier



Best Practice

Barrier must be at least 4 mil, able to withstand puncture and last 10 yrs

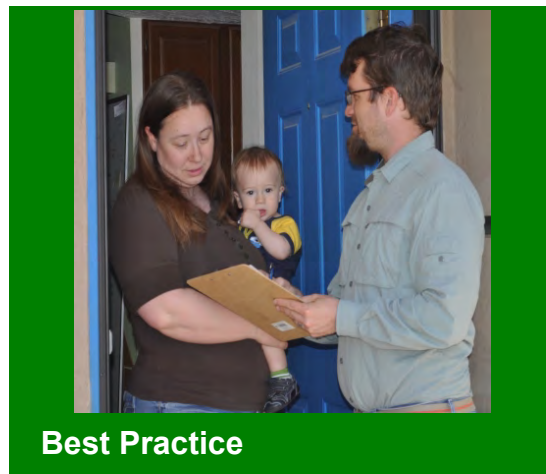

Best Practice

Talk to occupant about expected life of ground barrier and eventual need to replace it

Materials:

1. Plastic sheeting (at least 4 mil)
2. Furring strips
3. Fasteners

The higher a material's perm rating, the more vapor can pass through said material. Drywall typically has a perm rating of approximately 50. For vapor retarders in basements and crawl spaces, SWS calls for materials with a perm rating of <math><0.1</math> (which translates to 4mil or thicker). From 2007 IRC

definition of vapor retarders: Class I: ≤ 0.1 perm (called impermeable), Class II: 0.1 to 1.0 perm (called semi-impermeable), Class III: 1.0 perm to 10 perms (called semi-permeable).

2.0403.4c

Desired Outcome:

Durable, effective ground moisture barrier that provides ongoing access and minimizes ground vapor

Specification(s):

When seams exist, they will be overlapped a minimum of 12" using reverse or upslope lapping technique

Objective(s):

Keep water under the liner

Reduce likelihood of damage at seams



In Progress

Layer moisture barrier in a reverse shingle pattern so that uphill sheeting lays under downhill



Best Practice

Once layered, secure seams with landscape staples or tape

Tools:

1. Stapler
2. Utility knife
3. Drill

Materials:

1. Landscaping staples
2. Plastic sheeting (at least 4mil)
3. Ballast
4. Furring strips
5. Moisture-resistant adhesive tape

Two different colors of poly used to highlight different layers

2.0403.4c - Overlap seams



Determine which direction ground slopes and, if not working from uphill down, fold back barrier at lower areas



Measure uphill barrier at least 12 inches and mark where downhill barrier should reach



Layer downhill barrier over uphill to marked position, overlapping 12 inches, in reverse shingle pattern



Fasten seam with tape or landscape staples to prevent barrier from moving and allowing moisture infiltration

2.0403.4d

Desired Outcome:

Durable, effective ground moisture barrier that provides ongoing access and minimizes ground vapor

Specification(s):

Ground moisture barrier may be fastened to ground with durable fasteners

Objective(s):

Prevent movement of the ground moisture barrier

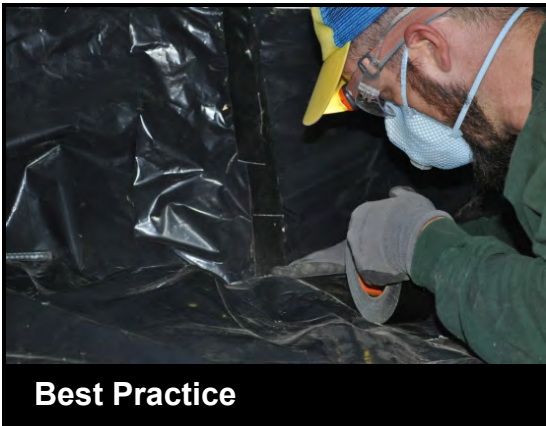

Best Practice

Taping seams with waterproof adhesive tape can prevent barrier from moving

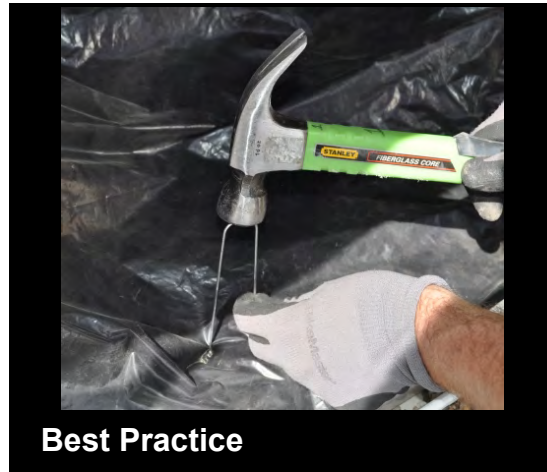

Best Practice

Fasten moisture barrier in place using ballast or corrosion-resistant fasteners, such as landscaping staples

Tools:

1. Hammer

Materials:

1. Landscaping staples
2. Ballast
3. Water-resistant adhesive tape

2.0404.1a

Desired Outcome:

Energy used to control humidity in conditioned spaces reduced

Specification(s):

Equipment will have a minimum efficiency level of ENERGY STAR® or better

Equipment will have a fan-off option

Equipment will retain settings after power-off

Equipment will have features that reduce both peak electric use (e.g., internal and external timers) and absolute energy use

Equipment will have standby losses of 1 watt or less

Controls will be labeled so they are understandable, readable, and accurate for occupant needs

Systems located in a basement or crawl space will be rated for cold temperature operation

Operating environment will be determined and appropriate equipment will be selected for that environment (e.g., low temperature and high relative humidity)

Objective(s):

Reduce energy use

Provide durable equipment

Control moisture

Provide equipment appropriate for occupant use

2.0404.1b

Desired Outcome:

Energy used to control humidity in conditioned spaces reduced

Specification(s):

Installation will proceed only when the following applicable steps have been taken to control moisture:

- Downspouts are redirected away from foundation
- Moisture from drying clothes is vented to the outside
- Sump pit is covered and sealed
- Dirt in crawl space is covered with a vapor barrier
- Plumbing leaks are eliminated

Equipment will be installed according to manufacturer specifications and meet all applicable codes

Equipment will be installed to permit adequate air flow

Equipment will have a timer for off-peak operation if time-of-use program is available and if the equipment can handle power interruptions

Any penetrations to the exterior of the home created by the installation of the appliance will be sealed

Initial relative humidity and temperature settings will be set by the installer to ensure the space does not reach dew point

Operation of controls and needed maintenance will be reviewed with occupant

A user guide for dehumidifier settings in different climate conditions will be created by the installer and provided to the occupant

Installer will commission the equipment to ensure it is functioning properly

An independent measurement will be made to verify relative humidity

System will be connected directly to condensate line that drains to a plumbing drain or the exterior, away from the home's foundation and in compliance with the plumbing code or the authority having jurisdiction

Specific information on the proper maintenance of the equipment will be provided to the occupant

Warranty information, operation manuals, and installer contact information will be provided to the occupant

Objective(s):

Reduce or retire dehumidifiers

Reduce allergens and asthma triggers

Improve health and reduce irritants

Improve building durability

Improve comfort

Reduce pest populations

Reduce risk of mold issues

Educate occupant on how to operate and maintain equipment

2.0404.1c

Desired Outcome:

Energy used to control humidity in conditioned spaces reduced

Specification(s):

Removed equipment will be recycled or disposed of properly in accordance with local regulations

Objective(s):

Prevent the reuse of inefficient equipment and its components

Reduce waste

Protect the environment

2.0404.2a

Desired Outcome:

A dry and moisture controlled space ensured

Specification(s):

Vents and other openings will be closed after ensuring sufficient combustion air for fuel burning appliances in accordance with 2012 IRC G2407.5.1

Objective(s):

Reduce moisture load coming from outside of the crawl space



🔊 Before

Verify that adequate combustion air is available before closing vents



Best Practice

Closed manufactured home foundation vent

IRC 2407 requires 50 cubic feet of volume in spaces where combustion appliances are located for every 1,000 Btuh of input. Ensure this requirement is met before closing off crawlspace vents.

2.0404.2a - Close vents



Close vents to reduce moisture load from outdoor air

2.0404.2b

Desired Outcome:

A dry and moisture controlled space ensured

Specification(s):

If liquid moisture is present, the area will be dried until any liquid moisture is eliminated

Objective(s):

Reduce moisture in the crawl space

Improve work environment



 Before

Eliminate water in crawlspace before work



 After

Dry crawlspace

Tools:

1. Wet/dry vacuum
2. Fan

Materials:

1. Mops
2. Towels

2.0404.2c

Desired Outcome:

A dry and moisture controlled space ensured

Specification(s):

Space will be dehumidified until wood moisture content in solid, untreated lumber is less than 20%

Objective(s):

Reduce moisture content of wood



👍 After

After correcting drainage and bulk moisture issues, use portable dehumidifiers to dry the space

Space has been dehumidified until moisture content in untreated lumber is less than 20%

Tools:

1. Moisture meter
2. Dehumidifier

2.0404.4a

Desired Outcome:

Basement humidity controlled with supplemental dehumidification

Specification(s):

A permanent, low-temperature, auto-restart, minimum ENERGY STAR® rated dehumidifier will be installed

Manufacturer specifications will be followed for size and use

Condensate will be drained to daylight or a condensation pump

Objective(s):

Maintain a dry basement

Reduce conditions conducive to mold growth, wood rot, and pests

2.0404.4b

Desired Outcome:

Basement humidity controlled with supplemental dehumidification

Specification(s):

Drying will be provided to all basement areas

Objective(s):

Maintain a dry basement

Reduce conditions conducive to mold growth, wood rot, and pests

2.0404.4c

Desired Outcome:

Basement humidity controlled with supplemental dehumidification

Specification(s):

All basement spaces will be maintained at a relative humidity that ensures condensation will not occur on cool surfaces

Objective(s):

Maintain a dry basement

Reduce conditions conducive to mold growth, wood rot, and pests

2.0404.4d

Desired Outcome:

Basement humidity controlled with supplemental dehumidification

Specification(s):

Condensing surfaces in basement will be insulated and sealed

Objective(s):

Maintain a dry basement

Reduce conditions conducive to mold growth, wood rot, and pests

2.0404.4e

Desired Outcome:

Basement humidity controlled with supplemental dehumidification

Specification(s):

Ventilation in the basement will be controlled to maintain relative humidity that ensures condensation will not occur on cool surfaces

Objective(s):

Maintain a dry basement

Reduce conditions conducive to mold growth, wood rot, and pests

2.0404.4f

Desired Outcome:

Basement humidity controlled with supplemental dehumidification

Specification(s):

Occupant will be educated on how and when to change filter and clean condensate drain of the dehumidifier in accordance with manufacturer specifications

Objective(s):

Ensure occupant health

Preserve integrity of system

2.0501.4a

Desired Outcome:

Pollutants are effectively vented

Specification(s):

Pier and skirting foundations will be vented in accordance with local climate conditions or code as required

Objective(s):

Provide ventilation for pollutant sources (e.g., moisture, radon, soil gases)

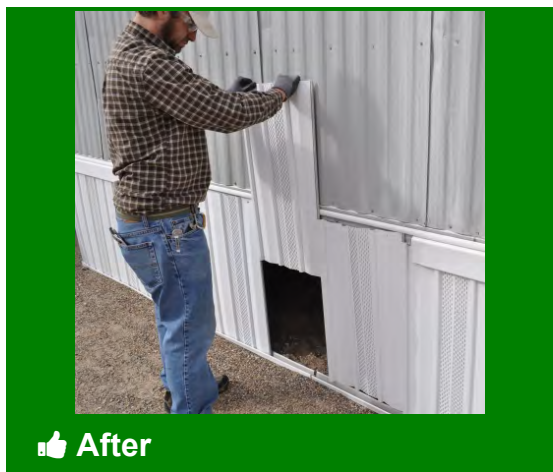

👍 After

Use ventilated skirting as required by local code

Tools:

1. Snips
2. Circular saw with fine-toothed paneling or vinyl siding blade (reversing the blade may help reduce chipping)
3. Mallet
4. Screw gun

Materials:

1. Skirting panels
2. Top rails, front and back
3. Ground channels and 7-inch spikes
4. Screw

2.0501.4b

Desired Outcome:

Pollutants are effectively vented

Specification(s):

Occupants will be educated on purpose, operation, and maintenance of vents

Objective(s):

Ensure vents function as intended



Teach homeowners how and when to operate foundation vents

Instruct homeowners that vents are intended to provide a path to outdoors for pollutants and soil moisture. Ideal settings for vents may be climate-dependents, but typically vents may be closed throughout the fall and winter when the air is relatively dry to conserve heat. They can be reopened when warmer weather begins in spring.

2.0501.4b - Occupant education



Close vents in fall or winter when heating season starts

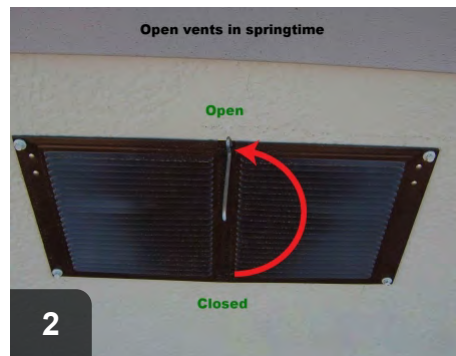

Open foundation vents in spring time when weather warms

2.0602.1a

Desired Outcome:

Prevention of static electric shock to the insulation installer when using rigid tubing

Specification(s):

Rigid fill tubes will be made of a material that will not hold an electric charge, such as Schedule 40 PVC Electrical Conduit, or be grounded

Objective(s):

Prevent injury to the installer



Best Practice

Rigid fill tubes should be low-conductivity and be grounded

Tools:

1. Wrench

Materials:

1. Couplers
2. Schedule 40 PVC fill tube
3. Grounding wire
4. Grounding rod

2.0602.1a - Rigid fill tube



Select rigid fill tubes that are low conductivity -- Schedule 40 PVC fill tube



Attach grounding wire to fill tubes to minimize shock risk



Attach grounding wire to rod with coupler



Blow insulation

2.0602.1b

Desired Outcome:

Prevention of static electric shock to the insulation installer when using rigid tubing

Specification(s):

For an additional level of protection, the metal coupler on the hose will be connected to the grounding wire

Grounding wire will be connected to the grounding rod

Grounding rod will be driven into the ground a minimum of 8' when possible; grounding wire will be connected in compliance with local code and authority having jurisdiction

Objective(s):

Divert static discharge of electricity to ground instead of installer



Unsafe

Ungrounded fill tubes can build up static electricity during insulation blowing



Best Practice

Fill tubes should be grounded to prevent electric shock to workers

Tools:

1. Sledgehammer
2. Wrench

Materials:

1. Grounding rod, at least 8'
2. Grounding wire
3. Metal coupler
4. Grounding coupler

2.0602.1b - Metal coupler grounding

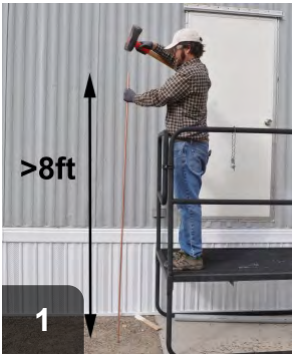

Copper grounding rod should be at least 8' long



Grounding rod should be driven into the ground so that nearly all of rod is underground

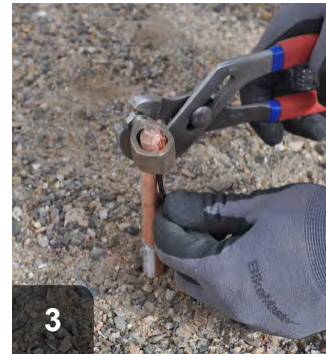

Attach grounding wire to rod with coupler



Attach grounding wire to fill tube

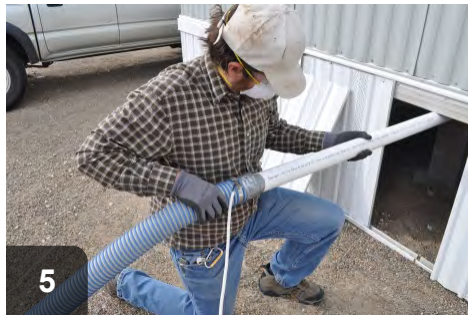

Blow in insulation with peace of mind that workers will not be electrocuted

2.0602.2a

Desired Outcome:

Prevention of injury to the installer and occupant, and prevent damage to the structure, if required by authority having jurisdiction

Specification(s):

Metal skin and frame will be grounded through the panel box to avoid electrical shock

Objective(s):

Prevent injury to the installer

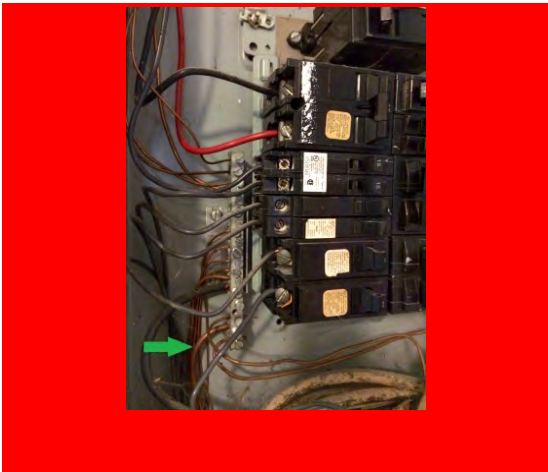

Locate 6- or 8-gauge solid copper ground wire in panel box

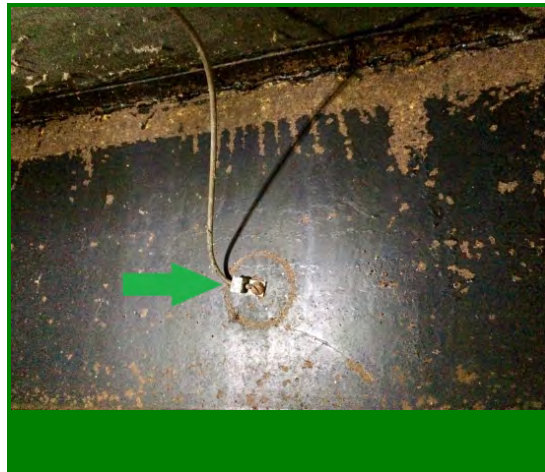

Verify that the ground wire is attached to the chassis (and metal siding if so equipped)

Tools:

1. Flashlight
2. Screwdriver (to remove panel box cover)

The frame and metal siding ground wire attachment points can be found under the home below the electric service entrance and panel box.

2.0602.2b

Desired Outcome:

Prevention of injury to the installer and occupant, and prevent damage to the structure, if required by authority having jurisdiction

Specification(s):

For an additional level of protection, metal fill tube will be connected to the grounding wire

Grounding wire will be connected to the copper grounding rod that is driven into the ground a minimum of 8' when possible and required by code or authority having jurisdiction

Objective(s):

Divert house electric current to ground instead of installer in the event of contact with a live wire



To prevent static electric shock, a grounding rod should be utilized

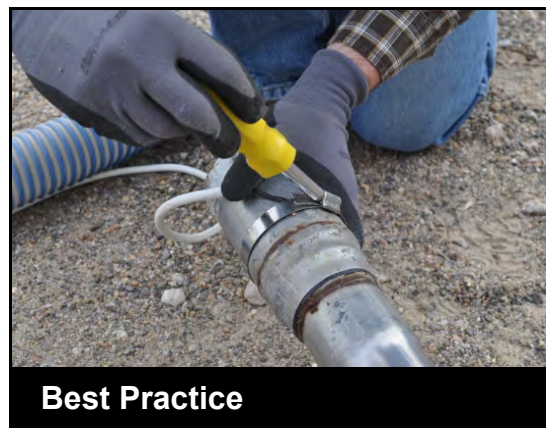

Attach grounding wire to metal of fill tube, not to flexible tubing

Tools:

1. Sledgehammer
2. Wrench

Materials:

1. Grounding rod, at least 8'
2. Grounding wire
3. Metal coupler
4. Metal fill tube

2.0602.2b - Metal fill tube grounding

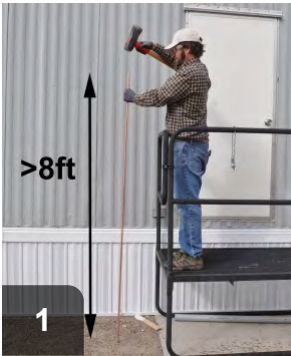

A copper grounding rod should be submerged at least 8 feet underground



Attach grounding wire to grounding rod with acorn coupler



Attach grounding wire to metal fill tube with metal coupler



Proceed with blowing insulation without fear of static shock

2.0602.2c

Desired Outcome:

Prevention of injury to the installer and occupant, and prevent damage to the structure, if required by authority having jurisdiction

Specification(s):

An electrical safety assessment will be performed

All electric tools will be protected by ground-fault circuit interrupters (GFCI)

Three-wire type extension cords will be used with portable electric tools

Worn or frayed electric cords will not be used

Water sources (e.g., condensate pans) and electrical sources will be kept separate

Metal ladders will be avoided

Aluminum foil products will be kept away from live wires

For arc flash hazards, NFPA 70E will be consulted

Objective(s):

Avoid electrical shock and arc flash hazards



Unsafe

Inspect house for unsafe electrical situations



Best Practice

Attics and crawl spaces should be inspected closely for electrical safety before work begins

2.0602.2c - Electrical tool safety



Use GFCIs and three-wire extension cords for all power tools



Electrical wiring should not be located near a water source



Use fiberglass ladders in place of metal

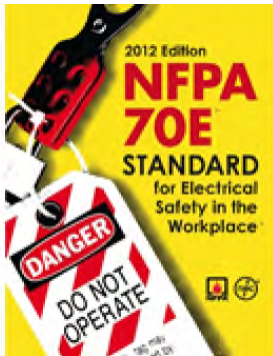

Follow NFPA 70E 2012 guidelines for arc flash hazards

2.0602.2d

Desired Outcome:

Prevention of injury to the installer and occupant, and prevent damage to the structure, if required by authority having jurisdiction

Specification(s):

If aluminum wiring is present, work on the home will be stopped until the suspect wiring is inspected and determined to be safe by a licensed electrician

After energy retrofit is completed, wiring will be reinspected by a licensed electrician

Objective(s):

Prevent injury to installer and occupant

Prevent damage to structure

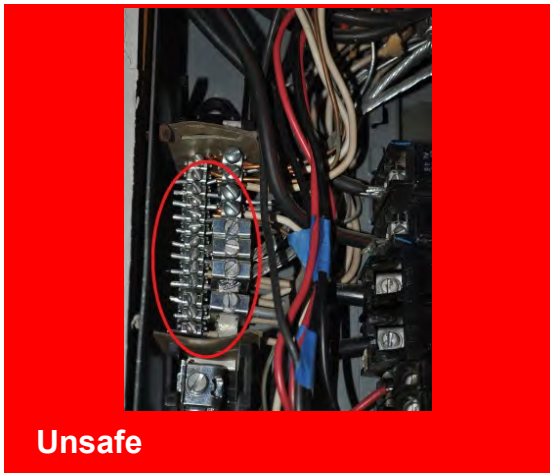

Have a certified electrician perform a load test before any weatherization work if aluminum wire is present.

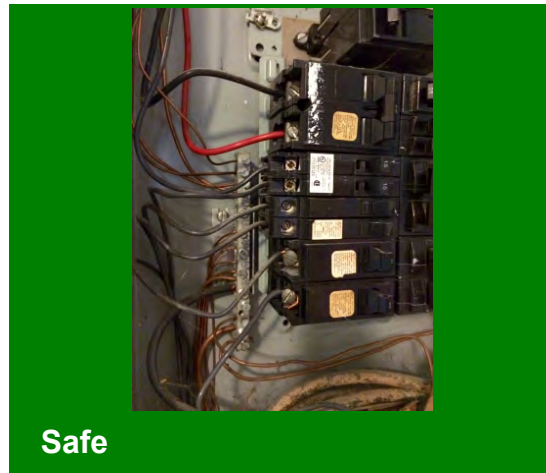

This panel does not contain aluminum wire.

Tools:

1. Screwdriver (to remove panel cover)
2. Flashlight

Check for the presence of aluminum wire (identified by its light gray color). If aluminum wire is present, do not work on the home until a certified electrician has performed a thorough inspection and determined that the wiring is safe.

2.0602.2d - Aluminum wiring



Inspect panel box for presence of (silver or gray colored) aluminum wire



Have a certified electrician inspect every aluminum wire connection in the home



After electrician verifies wiring is safe, proceed with retrofit work



Perform retrofit measures



When retrofit is complete, have certified electrician re-check wiring for safety

3.1001.4a

Desired Outcome:

Penetrations sealed to prevent air leakage and moisture movement between unconditioned and conditioned space

Specification(s):

Installer prework assessment will be conducted to determine:

- Structural integrity
- Roof leaks
- Insect infestation
- Accessibility
- Number, type, size, and location of penetrations

Objective(s):

Ensure work space is safe and ready for air sealing

Verify scope of work

3.1001.4b

Desired Outcome:

Penetrations sealed to prevent air leakage and moisture movement between unconditioned and conditioned space

Specification(s):

Backing or infill will be provided as needed to meet the specific characteristics of the selected material and the characteristics of the penetration or hole

The infill or backing will not bend, sag, or move once installed

All accessible damaged vapor barrier will be repaired

Penetration through the air barrier will be repaired

Objective(s):

Ensure closure is permanent and supports any load (e.g., wind, insulation, mechanical pressures)

Ensure sealant is effective and durable



Gaps around floor penetrations, such as plumbing, HVAC, and electrical



Gaps should be sealed to maintain air barrier

Tools:

1. Headlamp
2. Caulk gun

Materials:

1. Backer rod
2. Sealant
3. Adhesive tape
4. Plastic sheeting (at least 4 mil)

3.1001.4b - Air sealing penetrations



Prepare work space by removing any insulation



Infill with backer rod



Apply appropriate caulking to ensure backing/infill does not move



Visually inspect to verify no gaps remain



Patch holes in air and/or vapor barriers as well



Repair vapor barrier



Complete seal

3.1001.4c

Desired Outcome:

Penetrations sealed to prevent air leakage and moisture movement between unconditioned and conditioned space

Specification(s):

Sealants will be used to fill holes no larger than recommended by manufacturer specifications

Sealants will be compatible with all adjoining surfaces

Sealants will be continuous and meet fire barrier specifications, according to authority having jurisdiction

Objective(s):

Create a permanent seal

Ensure sealant meets or exceeds the performance characteristics of the surrounding materials

Create a continuous seal



Bad Practice

Avoid sealants that do not allow for expansion between dissimilar materials



Best Practice

Flexible sealants compensate for differential expansion and maintain a seal

Tools:

1. Caulk gun
2. Spray foam gun

Materials:

1. Caulk
2. Spray foam

3.1001.4c - Sealant selection



Caulking can be used to span gaps up to 1/4 inch



Spray foam can be used to span gaps up to 3 inches

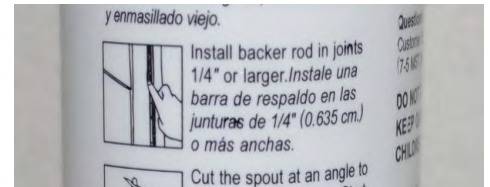

Check manufacturer specifications to verify spanning capabilities

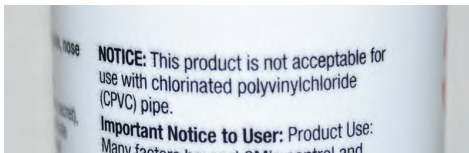

Also check manufacturer specs for incompatibility with intended surfaces

3.1001.4d

Desired Outcome:

Penetrations sealed to prevent air leakage and moisture movement between unconditioned and conditioned space

Specification(s):

Ceiling repair material must meet or exceed strength of existing ceiling material

Ceiling repair must span from truss to truss or add blocking as needed for support

The backing or infill will not bend, sag, or move once installed

All accessible damaged vapor barriers will be repaired

Penetrations through the air barrier must be repaired

Objective(s):

Ensure ceiling is structurally sound

Minimize air leakage

Ensure closure is permanent and supports expected wind and mechanical pressure loads

Ensure sealant does not fall out



 Before

Hole in drywall ceiling



In Progress

Drywall patch in place

Tools:

1. 6-inch and 12-inch drywall taping knives
2. Sanding block or sanding sponge
3. Utility knife
4. Keyhole saw
5. Screw gun

Materials:

1. Drywall or paneling
2. Fiberglass joint tape
3. Joint compound
4. Drywall screws
5. Support material if needed (typically 1X4, 1X6, or 2X4 dimensional lumber)

For holes in paneled ceilings, use matching panels for repairs. Consider replacing entire sections to avoid creating unsightly mismatched patches. For small holes, enlarge to a rectangular shape and install 1 X 4 blocks above two edges of the hole. For larger holes, enlarge opening to centers of nearest trusses and fasten the patch to the framing.

3.1001.4d - Ceiling hole repair

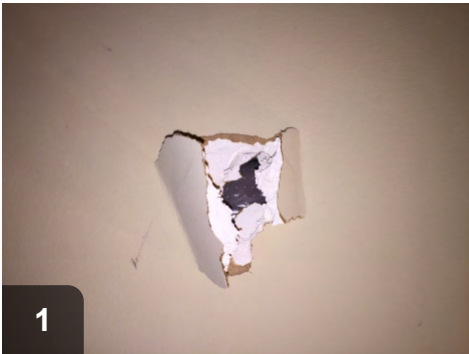

Replace any missing insulation and repair holes in vapor barrier



Prepare the hole by cutting the edges clean and square



Cut drywall and fasten in place



Add joint tape and first coat of joint compound

3.1001.4e

Desired Outcome:

Penetrations sealed to prevent air leakage and moisture movement between unconditioned and conditioned space

Specification(s):

Materials will be used or installed in accordance with product manufacturer specifications

Objective(s):

Select materials to ensure durable and permanent repair

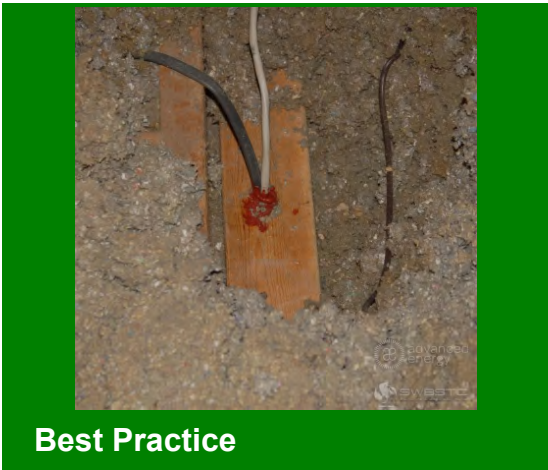

Choose durable, high quality sealants that are compatible with existing materials

Tools:

1. Caulking gun
2. Reusable spray foam gun
3. Utility knife

Materials:

1. Caulk
2. Foam sealant
3. Foam board
4. Drywall
5. Joint compound

3.1001.4f

Desired Outcome:

Penetrations sealed to prevent air leakage and moisture movement between unconditioned and conditioned space

Specification(s):

Only noncombustible materials will be used in contact with chimneys, vents, and flues

Local codes will be referenced

Objective(s):

Prevent a fire hazard



Before

Gaps around combustion exhaust flues need to be sealed

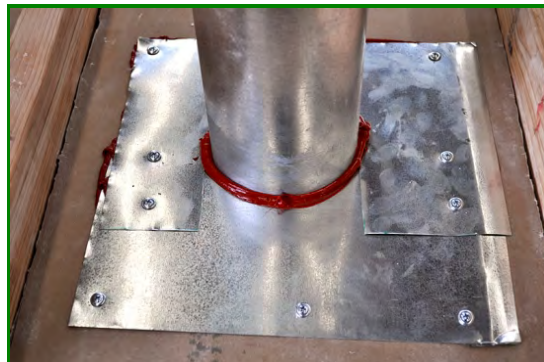

After

Sealed penetrations and chases should utilize high-temperature materials

Tools:

1. Drill/screwdriver
2. Caulk gun
3. Metal snips

Materials:

1. Fire caulk
2. Non-combustible material such as aluminum or galvanized steel flashing or cement board
3. Appropriate fasteners

3.1001.4f - High temperature application



1 Prepare work area by removing any insulation and debris



2 Use high-temperature caulking (600F min)



3 Apply first ring of caulking to match shape of opening



4 Apply second ring of caulking to size and shape of rigid material

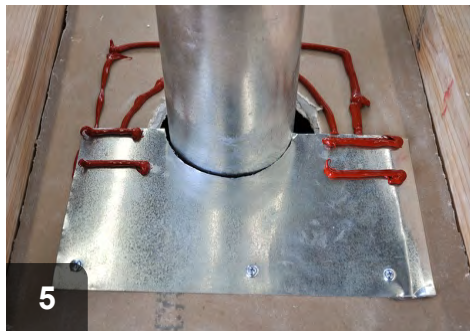

5 Fasten rigid material and apply additional caulking

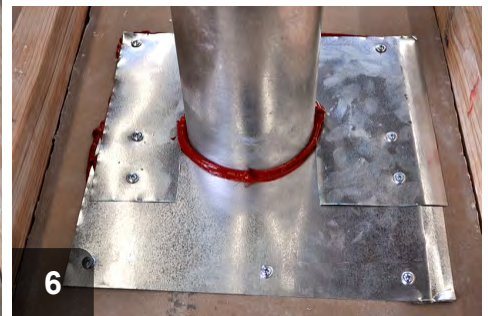

6 Fasten rigid material to cover penetration and seal against flue with caulk

3.1101.1a

Desired Outcome:

Penetrations sealed to minimize air leakage and moisture movement between unconditioned and conditioned space; all repairs will maintain structural integrity

Specification(s):

Installer prework assessment will be conducted to determine:

- Structural integrity
- Size of wall stud
- Insect infestation
- Accessibility
- Number, type, size, and location of penetrations

Objective(s):

Ensure work space is safe and ready for air sealing

Verify scope of work

3.1101.1b

Desired Outcome:

Penetrations sealed to minimize air leakage and moisture movement between unconditioned and conditioned space; all repairs will maintain structural integrity

Specification(s):

Like material and/or compatible materials will be used for repairs

Materials will be selected to comply with manufactured housing rules and regulations (e.g., Manufactured Housing Institute)

Objective(s):

Select materials to ensure durable and permanent repair

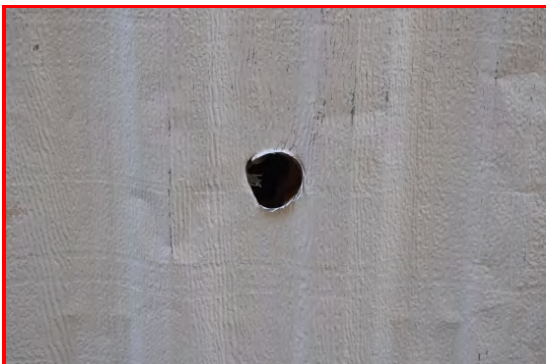

 Before

Hole in exterior wall of manufactured home aluminum siding



 After

Completed wall patch

Tools:

1. Sheet metal nibbler
2. Power saw
3. Snips
4. Screw gun
5. Caulking gun

Materials:

1. Aluminum siding or flashing
2. Oriented Strand Board (OSB) sheathing
3. Vinyl siding
4. Galvanized steel
5. Corrosion-resistant fasteners
6. High quality caulk formulated for exterior use

3.1101.1b - Materials



Replace damaged siding



Use siding that matches the existing material's contour, texture, and color

3.1101.1c

Desired Outcome:

Penetrations sealed to minimize air leakage and moisture movement between unconditioned and conditioned space; all repairs will maintain structural integrity

Specification(s):

All holes and penetrations on exterior surface of exterior walls will be sealed to ensure resistance to outdoor elements

Intentionally ventilated walls will not be sealed at vent locations (e.g., weep holes)

All holes and penetrations on the interior surface of exterior walls will be repaired

Backing or infill will be provided as needed to meet the specific characteristics of the selected sealant and the characteristics of the penetration

Objective(s):

Minimize air leakage

Maintain durability

Ensure resulting closure is permanent and supports expected load

Ensure sealant is effective and durable



 Before

Exterior penetrations need to be sealed with appropriate materials ensuring an air tight, weather tight seal.



 After

Exterior penetrations have been sealed with appropriate materials ensuring an air tight, weather tight seal.

Tools:

1. caulk gun

Materials:

1. weatherproof caulk

3.1101.1c - Exterior wall air sealing



Seams on aluminum siding must be tight.



Through the wall exhaust fan sealing.



Do not seal intentionally ventilated wall assemblies!

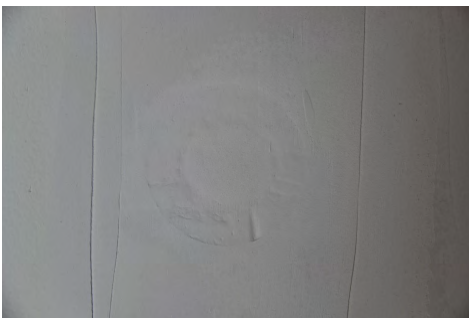

Backing or infill substrate may be needed for some wall patches.



Exterior electrical outlet sealing.

3.1101.2a

Desired Outcome:

Penetrations sealed to minimize air leakage and moisture movement between unconditioned and conditioned space; all repairs will maintain structural integrity

Specification(s):

Installer prework assessment will be conducted to determine:

- Structural integrity
- Size of wall stud
- Insect infestation
- Accessibility
- Number, type, size, and location of penetrations

Objective(s):

Ensure work space is safe and ready for air sealing

Verify scope of work

3.1101.2b

Desired Outcome:

Penetrations sealed to minimize air leakage and moisture movement between unconditioned and conditioned space; all repairs will maintain structural integrity

Specification(s):

All accessible holes and penetrations in top and bottom plates will be sealed

Backing or infill will be provided as needed to meet the specific characteristics of the selected sealant and the characteristics of the penetration

Objective(s):

Minimize air leakage

Maintain durability

Ensure resulting closure is permanent and supports expected wind and mechanical pressure loads

Ensure sealant is effective and durable



Unsealed penetrations through top plate



Sealed wiring penetrations through top plate

Tools:

1. Caulking gun
2. Reusable spray foam gun

Materials:

1. Caulk
2. Spray polyurethane foam
3. Foam backer rod or pieces of fiberglass batt

3.1101.2b - Interior wall air sealing



Locate and expose penetrations to prepare for sealant

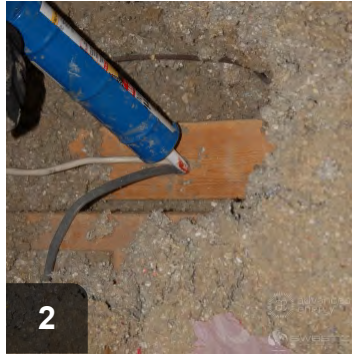

Use caulk or foam (approved by local code) to seal wiring penetrations through top plate

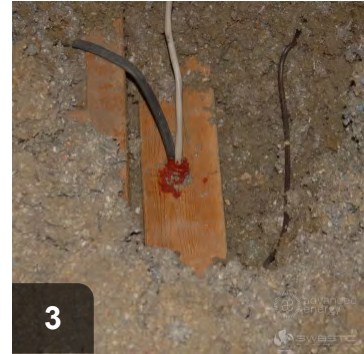

Ensure that all accessible gaps, holes, and penetrations are filled

3.1101.2c

Desired Outcome:

Penetrations sealed to minimize air leakage and moisture movement between unconditioned and conditioned space; all repairs will maintain structural integrity

Specification(s):

Like material and/or compatible materials will be used for repairs

Materials will be selected to comply with manufactured housing rules and regulations (e.g., Manufactured Housing Institute)

Objective(s):

Select materials to ensure durable and permanent repair



Identify wall material and patch holes with like material, such as drywall or panelling



Patch has been cut from drywall the same thickness as existing wall material

Tools:

1. Utility knife
2. Drill
3. Saw
4. Tape measure
5. Taping knife

Materials:

1. Drywall
2. Panelling
3. Fasteners
4. Wood for support
5. Spackle

3.1101.3a

Desired Outcome:

Penetrations sealed to minimize air leakage and moisture movement between unconditioned and conditioned space; all repairs to maintain structural integrity

Specification(s):

Installer prework assessment will be conducted to determine:

- Structural integrity
- Insect infestation
- Accessibility
- Number, type, size, and location of penetrations
- Identify marriage walls and lines

Objective(s):

Ensure work space is safe and ready for air sealing

Verify scope of work

3.1101.3b

Desired Outcome:

Penetrations sealed to minimize air leakage and moisture movement between unconditioned and conditioned space; all repairs to maintain structural integrity

Specification(s):

All accessible holes and penetrations in top and bottom plates will be sealed

Backing or infill will be provided as needed to meet the specific characteristics of the selected sealant and the characteristics of the penetration

Objective(s):

Minimize air leakage

Maintain durability

Ensure resulting closure is permanent and supports expected wind and mechanical pressure loads

Ensure sealant is effective and durable

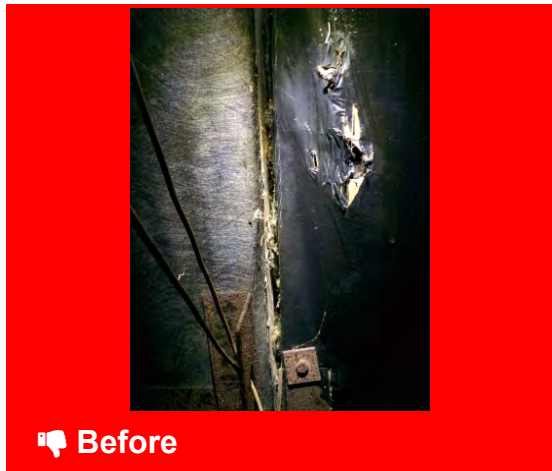

Cobwebs may indicate air leaks at the marriage line



Completed air sealing at marriage line

Tools:

1. Caulking gun
2. Reusable spray foam gun

Materials:

1. Extruded polystyrene ((XPS) foam board
2. Caulk
3. Spray foam
4. Foam backer rod or fiberglass batt insulation

3.1101.3b - Marriage wall air sealing of holes and penetrations



1 Clean belly wrap before air sealing

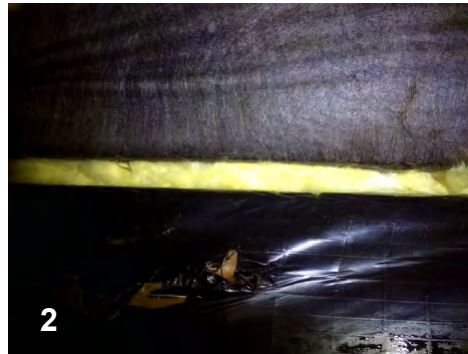

2 Stuff wide gaps in the marriage line with fiberglass insulation or foam backer rod before applying sealant



3 Apply foam or caulking over backer

3.1101.3c

Desired Outcome:

Penetrations sealed to minimize air leakage and moisture movement between unconditioned and conditioned space; all repairs to maintain structural integrity

Specification(s):

All accessible holes and penetrations at marriage lines will be sealed continuously at end walls, floors, and ceiling

Backing or infill will be provided at the marriage line as needed

All remaining gaps will be sealed with an approved material

Objective(s):

Minimize air leakage

Maintain durability

Ensure sealant is effective and durable

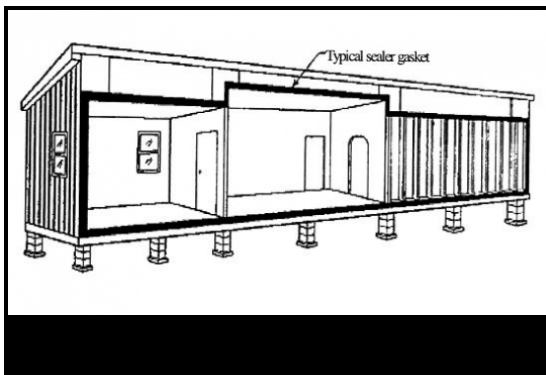

Identify leaks in marriage line using a blower door

Tools:

1. Reusable spray foam gun
2. Caulking gun
3. Utility knife
4. Tape measure
5. Square
6. Screw gun
7. Hammer
8. Prybar
9. Blower door
10. Chemical smoke dispenser

Materials:

1. Caulk
2. Spray foam
3. Foam board
4. Screws

You may need to remove trim to determine what type of sealing is needed at the marriage line. Some original installations use a compressed open-cell polyurethane foam sealing strip with excellent air sealing properties and will need little or no additional work. Other installations may feature fiberglass or other ineffective air sealing measures and require extensive caulking and foaming to reduce air infiltration. Use a blower door to **pressurize** the house and use smoke to pinpoint leak locations.

3.1101.3c - Marriage line air sealing



Identify leaks in marriage line using a blower door and smoke



Foam, caulk, and seal leaks between halves of double wide manufactured homes

3.1101.3d

Desired Outcome:

Penetrations sealed to minimize air leakage and moisture movement between unconditioned and conditioned space; all repairs to maintain structural integrity

Specification(s):

Materials will be used or installed in accordance with product manufacturer specifications

Objective(s):

Select materials to ensure durable and permanent repair



 Before

Hole in exterior wall of manufactured home aluminum siding



 After

Completed wall patch

Tools:

1. Sheet metal nibbler
2. Snips
3. Screw gun
4. Caulking gun

Materials:

1. Aluminum siding or flashing
2. Caulk (formulated for exterior use)
3. Corrosion-resistant fasteners

3.1201.5a

Desired Outcome:

Windows and doors are operable, sealed, and weathertight

Specification(s):

Installer prework assessment will be conducted to determine:

- Number
- Type
- Operating condition
- Wall construction

Objective(s):

Ensure work space is safe and ready for air sealing

Verify scope of work

3.1201.5b

Desired Outcome:

Windows and doors are operable, sealed, and weathertight

Specification(s):

Presence of lead-based paint in pre-1978 homes will be assumed unless testing confirms otherwise; documentation of testing results will be kept on file

EPA's Renovation, Repair and Painting (RRP) Program Rule (40 CFR Part 745) in pre-1978 homes and proposed changes to this rule (Federal Register/Vol. 75, No. 87/May 6, 2010) will be complied with, to be superseded by any subsequent final rulemaking or any more stringent state or federal standards

Objective(s):

Protect worker and occupant from potential lead hazards



In homes built before 1978, test paint before beginning renovation

Tools:

1. Note: Mask must be worn during testing
2. LeadCheck test kit
3. Utility knife
4. Camera

EPA RRP certification required to conduct Lead Paint assessment.

3.1201.5b - Lead paint assessment



1
Clean tools and sample site to prevent contamination



2
Cut sample site at an angle to expose all older paint layers



3
Break capsules and shake to mix reagents. Swab sample site for 30 seconds



4
Check swab for reaction



5
Red indicates lead positive. White indicates lead negative



6
If negative, verify validity of test with provided calibration card



7
Lead in calibration card should test positive and turn red

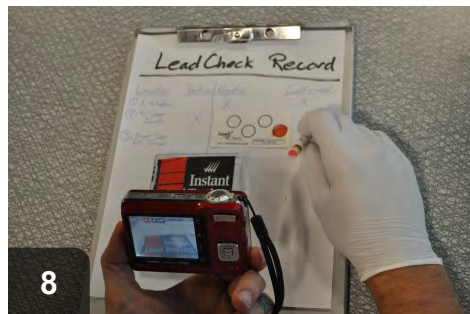

8
Record test results to maintain documentation

3.1201.5c

Desired Outcome:

Windows and doors are operable, sealed, and weathertight

Specification(s):

All egress windows will be operable as required by local codes

All egress doors will be operable as required by local codes

Objective(s):

Maintain operability of egress windows and doors



Windows and doors should be free and clear of obstructions and operate smoothly with no special knowledge.

3.1201.5c - Operable windows and doors



Window sill height should be no more than 44 inches from the floor.



Egress windows should be more than 24" high.



Egress windows should be more than 20" wide.



Doors should open easily from the inside, with no key or special knowledge of the locking system.



Manufactured housing should have two egress doors located away from one another. Stairs or ramps may be needed outside.

3.1201.5d

Desired Outcome:

Windows and doors are operable, sealed, and weathertight

Specification(s):

Details that reduce air infiltration will be repaired, replaced, sealed, or installed (e.g., plastic gliders, weatherstripping, cranks, latches, locks, knobs, thresholds)

Objective(s):

Reduce air infiltration

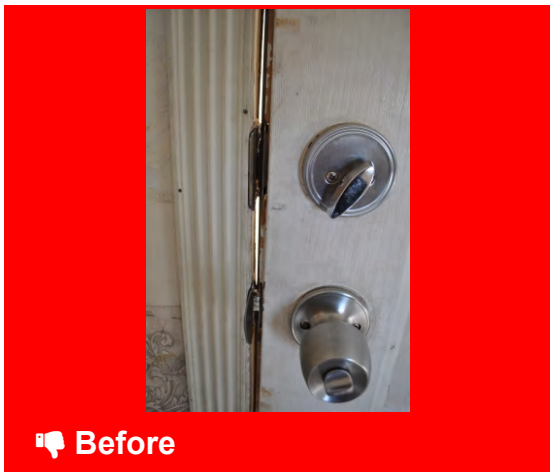

Light visible through door jamb indicates air infiltration



After weatherstripping and adjustment of door in jamb, air infiltration is eliminated

Tools:

1. Drill/screwdriver
2. Utility knife
3. Tape measure
4. Caulk gun
5. Metal snips

Materials:

1. Weatherstripping
2. Door sweep
3. Fasteners
4. Caulk
5. Felt corner pads

3.1201.5d - Air infiltration



1
Door jamb is missing any weatherstripping



2
Measure door jamb for weatherstripping



3
Install new weatherstrip



4
Measure bottom of door for door sweep



5
Install new door sweep

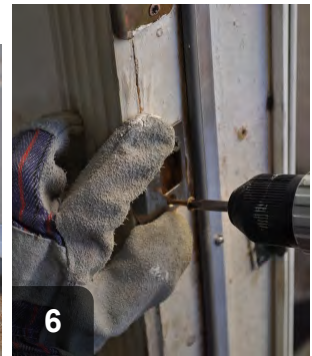

6
Adjust strike-plate and door jambs as necessary to secure a good fit

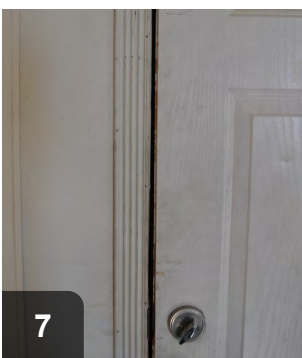

7
If properly adjusted, light should no longer be visible around door and air movement should no longer be detected

3.1201.5e

Desired Outcome:

Windows and doors are operable, sealed, and weathertight

Specification(s):

Details that reduce water infiltration will be repaired, replaced, or installed (e.g., replace missing glazing on sash, exterior caulking, exterior storm windows, storm doors, drip cap, J-channel, flashing)

Objective(s):

Reduce water infiltration



Install and caulk drip caps over manufactured home windows



Install and caulk drip caps over manufactured home doors

Tools:

1. Caulking gun
2. Cordless driver/drill
3. Razor scraper
4. Metal snips

Materials:

1. Caulk formulated for exterior use with 20-year or greater durability
2. Glass
3. Glazing strips
4. J-channel
5. Putty tape
6. Flashing

3.1201.5f

Desired Outcome:

Windows and doors are operable, sealed, and weathertight

Specification(s):

Materials will be used or installed in accordance with product manufacturer specifications

Objective(s):

Select materials to ensure durable and permanent repair

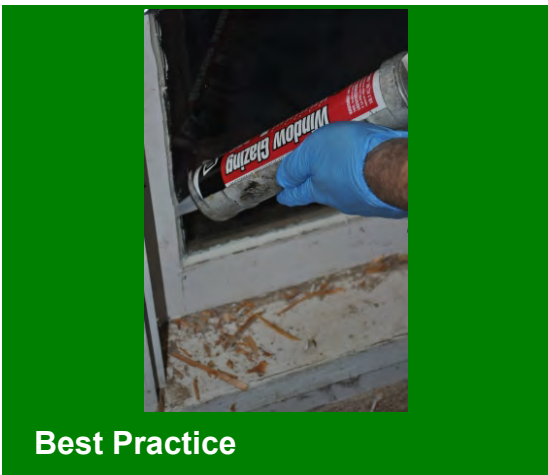

Best Practice

Read manufacturer specifications to ensure proper use of materials

3.1201.5g

Desired Outcome:

Windows and doors are operable, sealed, and weathertight

Specification(s):

Windows and doors will be adjusted to properly fit the jamb and allow for ease of operation and security

Objective(s):

Ensure proper operation of the window, door, and hardware

Ensure air and watertight installation

3.1201.5h

Desired Outcome:

Windows and doors are operable, sealed, and weathertight

Specification(s):

Occupants will be notified of changes or repairs made and will be educated on how to operate and maintain windows and doors

Objective(s):

Ensure long-term weathertightness

3.1201.6a

Desired Outcome:

Minimize air infiltration through existing leaky windows while maintaining safe egress for occupants

Specification(s):

Installer prework assessment will be conducted to determine:

- Number
- Type
- Size
- Condition of opening

Objective(s):

Verify scope of work

3.1201.6b

Desired Outcome:

Minimize air infiltration through existing leaky windows while maintaining safe egress for occupants

Specification(s):

Fixed interior storm windows will not be installed in egress locations

Objective(s):

Safety



Do not install fixed storm windows in bedroom windows designated as egress locations

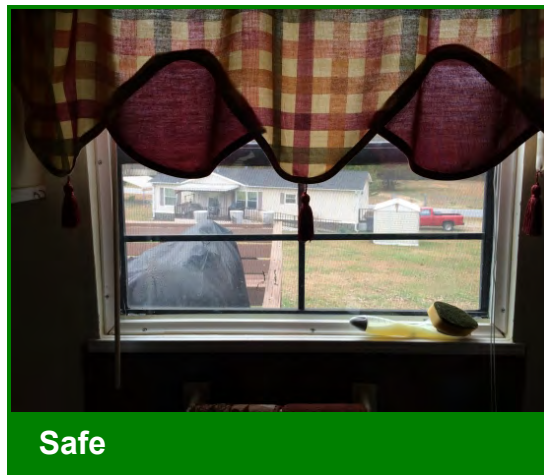

Fixed storm windows may be installed in non-egress locations only

Storm windows installed in egress (bedroom) windows must be operable or removable, and conform to the following standard: Voluntary Standard Egress Window Systems for Utilization in Manufactured Housing, AAMA 1704-85

3.1201.6c

Desired Outcome:

Minimize air infiltration through existing leaky windows while maintaining safe egress for occupants

Specification(s):

Operable interior storm windows will be installed in accordance with manufacturer specifications

Objective(s):

Minimize air leakage

Provide safe egress for occupants



No interior storm window has been installed.



Storm window has been installed according to manufacturers specifications and operates smoothly.

Tools:

1. drill

Materials:

1. mechanical fasteners
2. weatherstripping

3.1201.6c - Installing operable storm window



Ensure the perimeter surfaces are clean and ready to accept sealant.



Install weatherstrip or other appropriate sealant to the perimeter of the opening.



Install the window, ensuring it is level in the opening.



Secure the window to the opening, being sure the mechanical fasteners compress the desired sealant.



Storm window has been installed according to manufacturers specifications and operates smoothly.

3.1201.6d

Desired Outcome:

Minimize air infiltration through existing leaky windows while maintaining safe egress for occupants

Specification(s):

Interior storm windows will be operable and egress rated in egress locations

Objective(s):

Provide safe egress for occupants



Only operable storm windows conforming to HUD standards may be installed in egress (bedroom) windows

Storm windows installed in egress (bedroom) windows must be operable or removable, and conform to the following standard: Voluntary Standard Egress Window Systems for Utilization in Manufactured Housing, AAMA 1704-85

3.1201.6e

Desired Outcome:

Minimize air infiltration through existing leaky windows while maintaining safe egress for occupants

Specification(s):

Occupants will be educated on the proper use and maintenance of storm windows

Objective(s):

Ensure weathertightness and safety

3.1202.3a

Desired Outcome:

Glass complete and intact

Specification(s):

Installer prework assessment will be conducted to determine:

- Number
- Type
- Location
- Operating condition
- Wall construction
- Size

Objective(s):

Ensure that work space is safe and ready for glass replacement

Verify scope of work

3.1202.3b

Desired Outcome:

Glass complete and intact

Specification(s):

Presence of lead-based paint in pre-1978 homes will be assumed unless testing confirms otherwise; documentation of testing results will be kept on file

EPA's Renovation, Repair and Painting (RRP) Program Rule (40 CFR Part 745) in pre-1978 homes and proposed changes to this rule (Federal Register/Vol. 75, No. 87/May 6, 2010) will be complied with, to be superseded by any subsequent final rulemaking or any more stringent state or federal standards

Objective(s):

Protect worker and occupant from potential lead hazards



Best Practice

In homes built before 1978, test paint before beginning renovation

Tools:

1. Note: Mask must be worn during testing
2. LeadCheck test kit
3. Utility knife
4. Camera

EPA RRP certification required to conduct Lead Paint assessment.

3.1202.3b - Lead paint assessment



1 Clean tools and sample site to prevent contamination



2 Cut sample site at an angle to expose all older paint layers



3 Break capsules and shake to mix reagents. Swab sample site for 30 seconds



4 Check swab for reaction



5 Red indicates lead positive. White indicates lead negative



6 If negative, verify validity of test with provided calibration card



7 Lead in calibration card should test positive and turn red

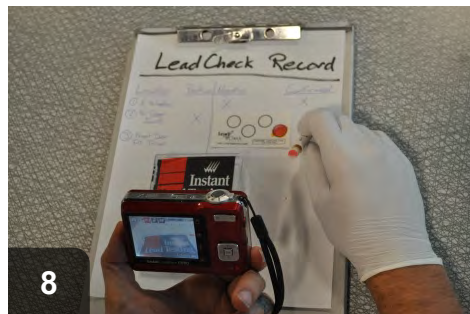

8 Record test results to maintain documentation

3.1202.3c

Desired Outcome:

Glass complete and intact

Specification(s):

Damaged glass will be removed

Objective(s):

Safely remove old glass



Before

Broken or cracked window glass should be replaced to minimize air leakage



In Progress

Broken glass needs to be cleared away completely before installing new glass

Tools:

1. Brush
2. Dust pan
3. Vacuum
4. Utility knife
5. Gloves

3.1202.3c - Broken glass removal



1 Remove exterior stops--these will probably not be salvagable



2 Wearing protective gloves, remove large glass pieces carefully



3 Sweep up all remaining small glass slivers



4 Sash should be completely clear of debris before moving forward with installation

3.1202.3d

Desired Outcome:

Glass complete and intact

Specification(s):

Opening will be cleaned

Original sealant/material will be removed

Objective(s):

Prepare opening for new glass



In Progress

Remove all debris, glazing tape, and glass from sash



In Progress

Sash surface must be clean before mounting new glass

Tools:

1. Scraper
2. Lint-free cloth

Materials:

1. Cleaning solution or cleaning wipes

3.1202.3d - Opening preparation



Clean all sealant and glazing off sash to return to smooth surface



Clean sash with cleaning solution and lint-free cloth. Allow to dry before applying sealant

3.1202.3e

Desired Outcome:

Glass complete and intact

Specification(s):

Replacement glass will be sized to original width, height, and depth

Stops will be replaced or installed

Glass will be sealed in accordance with original installation design

Glass will be selected with comparable tint and coating (color and look)

Tempered or safety glass will be used as required by local code

Objective(s):

Install, seal, and secure new glass in place



Sash should be completely clear debris before installing new glass



Replacement glass should match previous tint and dimensions, and be tempered, if location requires it

Tools:

1. Caulk gun
2. Tape measure

Materials:

1. New glass, measured to fit, tempered if necessary
2. Glazing or replacement stops
3. Adhesive sealant
4. Window cleaner

3.1202.3e - New glass installation



1 Measure sash for width of replacement glass -- cut glass to 1/4" less than sash width



2 Measure sash for height of replacement glass -- cut glass to 1/4" less than sash height



3 Apply sealant to sash with bead at least 3/16" wide



4 Run sealant bead around entire sash to seal glass from the interior



5 Install new glass, ensuring 1/8" gap from frame on all sides



6 Apply glazing or install replacement stops to seal window from exterior



7 Clean glass to ensure than no out of place adhesive or glazing remains to bake onto glass

3.1203.3a

Desired Outcome:

Smooth operation and an airtight and weathertight fit of replacement windows and doors

Specification(s):

Installer prework assessment will be conducted to determine:

- Number
- Type
- Operating condition
- Wall construction

Objective(s):

Ensure work space is safe and ready for air sealing

Verify scope of work

3.1203.3b

Desired Outcome:

Smooth operation and an airtight and weathertight fit of replacement windows and doors

Specification(s):

Presence of lead-based paint in pre-1978 homes will be assumed unless testing confirms otherwise; documentation of testing results will be kept on file

EPA's Renovation, Repair and Painting (RRP) Program Rule (40 CFR Part 745) in pre-1978 homes and proposed changes to this rule (Federal Register/Vol. 75, No. 87/May 6, 2010) will be complied with, to be superseded by any subsequent final rulemaking or any more stringent state or federal standards

Objective(s):

Protect worker and occupant from potential lead hazards



Best Practice

In homes built before 1978, test paint before beginning renovation

Tools:

1. Note: Mask must be worn during testing
2. LeadCheck test kit
3. Utility knife
4. Camera

EPA RRP certification required to conduct Lead Paint assessment.

3.1203.3b - Lead paint assessment



1
Clean tools and sample site to prevent contamination



2
Cut sample site at an angle to expose all older paint layers



3
Break capsules and shake to mix reagents. Swab sample site for 30 seconds



4
Check swab for reaction



5
Red indicates lead positive. White indicates lead negative



6
If negative, verify validity of test with provided calibration card



7
Lead in calibration card should test positive and turn red

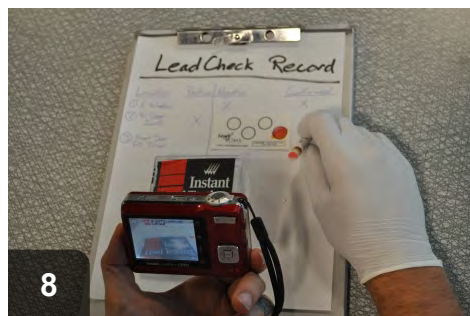

8
Record test results to maintain documentation

3.1203.3c

Desired Outcome:

Smooth operation and an airtight and weathertight fit of replacement windows and doors

Specification(s):

Window or door units will be designed for manufactured home use and will be ENERGY STAR qualified

Rough opening will be measured before ordering replacements

Access to emergency egress points, such as primary windows or exit doors, will be considered during the selection of retrofit window or door units

Objective(s):

Ensure proper size, type, and operation of window or door

3.1203.3d

Desired Outcome:

Smooth operation and an airtight and weathertight fit of replacement windows and doors

Specification(s):

Existing units will be removed

Opening will be cleaned

Any damaged framing will be replaced

Opening for installation will be prepared in accordance with manufacturer specifications

Objective(s):

Provide a clean opening for replacement unit

3.1203.3e

Desired Outcome:

Smooth operation and an airtight and weathertight fit of replacement windows and doors

Specification(s):

Window or door units will be installed in accordance with manufacturer specifications

Objective(s):

Ensure replacement window or door operates properly

Ensure replacement window or door has a weathertight fit

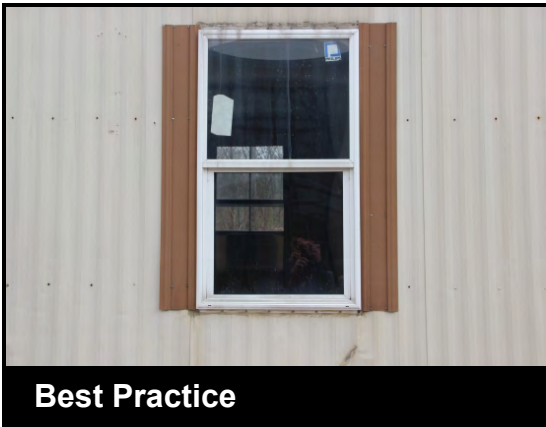

Window is installed per manufacturer's specifications and adheres to local codes.

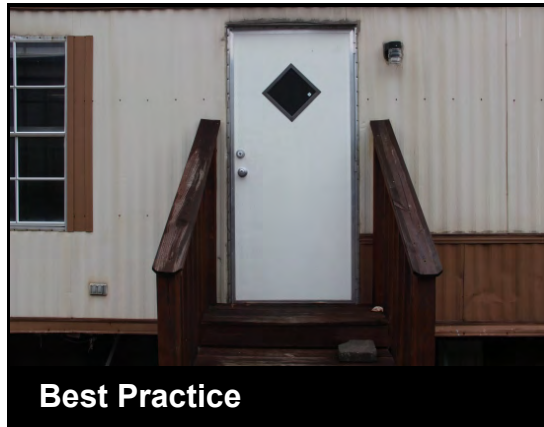

Door is installed to manufacturer's specifications and adheres to local codes.

3.1203.3e - Window and door installation



Door has a lockset that is easily operable from the inside without a key or special instruction.



Egress doors are the proper width for egress.



Egress doors are the proper height for egress.



Windows are the proper height for egress.



Windows are the proper width for egress.



Window sill height is within code guidelines.

3.1203.3f

Desired Outcome:

Smooth operation and an airtight and weathertight fit of replacement windows and doors

Specification(s):

Egress windows will only be replaced with egress windows

Objective(s):

Provide safe egress for occupants



Egress window in bedroom of manufactured house

Windows installed in egress (bedroom) windows must conform to the following standard: Voluntary Standard Egress Window Systems for Utilization in Manufactured Housing, AAMA 1704-85

3.1203.3g

Desired Outcome:

Smooth operation and an airtight and weathertight fit of replacement windows and doors

Specification(s):

Occupants will be notified of changes or repairs made and will be educated on how to operate and maintain window or door

Objective(s):

Ensure long-term weathertightness

3.1301.1a

Desired Outcome:

Penetrations sealed to minimize air leakage and moisture movement between unconditioned and conditioned space

Specification(s):

Installer prework assessment will be conducted to determine:

- Structural integrity
- Standing water
- Raw sewage
- Insect infestation
- Pests
- Accessibility
- Number, type, size, and location of penetrations

Objective(s):

Ensure work space is safe and ready for air sealing

Verify scope of work

3.1301.1b

Desired Outcome:

Penetrations sealed to minimize air leakage and moisture movement between unconditioned and conditioned space

Specification(s):

Patching material will be provided as needed to meet the specific characteristics of the bottom board material and the characteristics of the hole

Patch will have a service life of a minimum of 20 years

Objective(s):

Minimize air leakage

Keep insulation in place

Ensure repair materials are compatible

Ensure patch will support insulation

3.1301.1c

Desired Outcome:

Penetrations sealed to minimize air leakage and moisture movement between unconditioned and conditioned space

Specification(s):

Patching will be provided as needed to meet both the specific characteristics of the bottom board material and the characteristics of the hole

Patch will not bend, sag, or move once installed

Patch will be permanent

Objective(s):

Minimize air leakage

Ensure repair materials are compatible

Minimize hole size to ensure successful use of sealant

Ensure closure is permanent and supports insulation

Ensure sealant does not fall out

3.1301.1d

Desired Outcome:

Penetrations sealed to minimize air leakage and moisture movement between unconditioned and conditioned space

Specification(s):

Combustion air supplies will be labeled for identification and will not be blocked or sealed

Penetrations will be sealed to meet both the specific characteristics of the bottom board material and the characteristics (hole size and type) of the penetrations (e.g., electrical, PVC, gas line, dryer vent)

The patch will not bend, sag, or move once installed

Objective(s):

Ensure combustion equipment is not compromised

Minimize air leakage around penetrations



 Before

Unsealed penetration through bottom board



 After

Properly sealed penetration through manufactured home bottom board

Tools:

1. Outward clinching (stitch) stapler
2. Utility knife
3. Cordless driver/drill
4. Reusable foam gun
5. Caulking gun
6. Nail gun

Materials:

1. Belly/bottom board fabric
2. Belly/bottom board repair tape
3. Staples
4. Screws
5. Foam board
6. 1X2 nailers
7. Spray foam sealant
8. High quality exterior caulk

3.1301.1d - Bottom board penetrations



Label combustion air inlets with the words, "DO NOT SEAL"

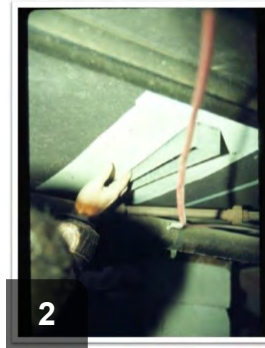

Seal around penetrations with compatible materials like foam board, belly board, house wrap, or Flex Mend (tm)

3.1301.1e

Desired Outcome:

Penetrations sealed to minimize air leakage and moisture movement between unconditioned and conditioned space

Specification(s):

Materials will be selected to comply with manufactured housing rules and regulations (e.g., Manufactured Housing Institute)

Surface preparation and material selected will be used or installed in accordance with product manufacturer specifications

Objective(s):

Select materials to ensure durable and permanent repair

3.1301.2a

Desired Outcome:

Penetrations sealed to minimize air leakage and moisture movement between unconditioned and conditioned space; all repairs will maintain structural integrity

Specification(s):

Installer prework assessment will be conducted to determine:

- Structural integrity
- Insect infestation
- Pests
- Accessibility
- Plumbing leaks
- Number, type, size, and location of penetrations

Objective(s):

Ensure work space is safe and ready for air sealing

Verify scope of work

3.1301.2b

Desired Outcome:

Penetrations sealed to minimize air leakage and moisture movement between unconditioned and conditioned space; all repairs will maintain structural integrity

Specification(s):

Backing or infill will be provided as needed to meet the specific characteristics of the selected sealant and the characteristics of the penetration

The backing or infill will not bend, sag, or move once installed

Objective(s):

Ensure resulting closure is permanent and supports expected load

Ensure sealant is effective and durable



Gaps around floor penetrations, such as plumbing, HVAC, and electrical



Gaps should be sealed to maintain air barrier

Tools:

1. Headlamp

Materials:

1. Backer rod
2. Sealant

3.1301.2b - Floor air sealing (decking, subfloor, floor decking)



Prepare work space by removing any insulation



Infill with backer rod



Apply appropriate caulking to ensure backing/infill does not move



Visually inspect to verify no gaps remain

3.1301.2c

Desired Outcome:

Penetrations sealed to minimize air leakage and moisture movement between unconditioned and conditioned space; all repairs will maintain structural integrity

Specification(s):

Sealants will be used to fill holes no larger than recommended by manufacturer specifications

Sealants will be compatible with all adjoining surfaces

Sealants will be continuous and meet fire barrier specifications, if required

Objective(s):

Ensure sealant meets or exceeds the performance characteristics of the surrounding materials

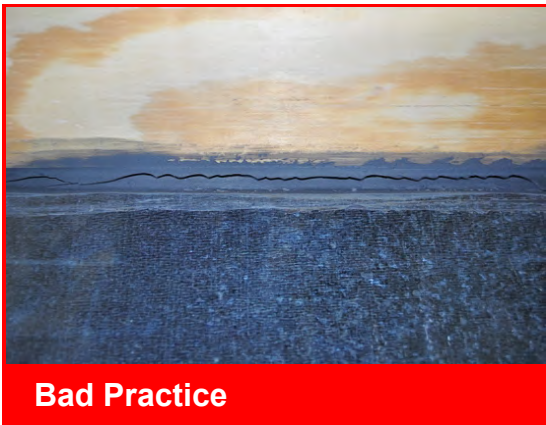

Bad Practice

Avoid sealants that do not allow for expansion between dissimilar materials

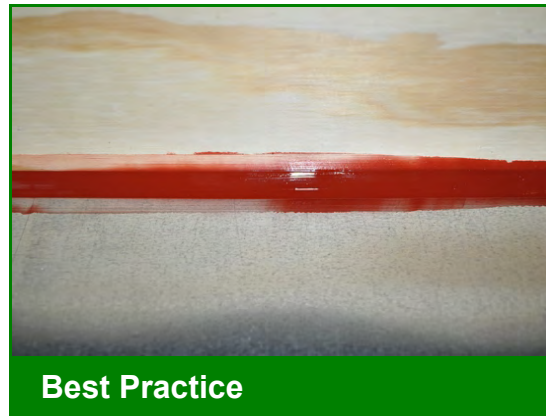

Best Practice

Flexible sealants compensate for differential expansion and maintain a seal

Tools:

1. Caulk gun
2. Spray foam gun

Materials:

1. Caulk
2. Spray foam

3.1301.2c - Sealant selection



Caulking can be used to span gaps up to 1/4 inch



Spray foam can be used to span gaps up to 3 inches

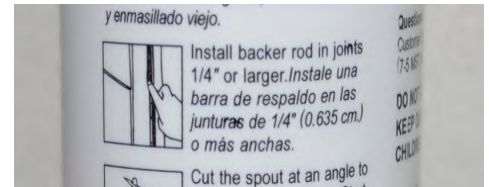

Check manufacturer specifications to verify spanning capabilities

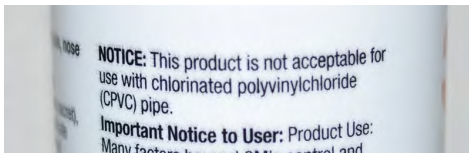

Also check manufacturer specs for incompatibility with intended surfaces

3.1301.2d

Desired Outcome:

Penetrations sealed to minimize air leakage and moisture movement between unconditioned and conditioned space; all repairs will maintain structural integrity

Specification(s):

Floor repair material will meet or exceed strength of existing floor material

Repair will span from joist to joist and blocking added as needed to support floor

Patches smaller than 144 square inches will not require repairs from joist to joist

Floor repair material will be glued, fastened, and air sealed

Objective(s):

Ensure floor is structurally sound

Minimize air leakage



Remove floor coverings from damaged area



Completed floor repair

Tools:

1. Circular saw
2. Reciprocating saw
3. Caulking gun
4. Cordless driver/drill
5. Framing square
6. Speed square
7. Utility knife
8. Sawhorses
9. Clamps
10. Jig saw or keyhole saw
11. Paddle bits to drill starter holes in floor

Materials:

1. 5/8" or 3/4" oriented strand board or plywood subflooring
2. Polyurethane caulk
3. Construction adhesive
4. 2" deck screws
5. 3" deck screws
6. 8-penny galvanized ring shank or spiral shank nails
7. 16-penny galvanized ring shank or spiral shank nails
8. 2X4, or 2X6 blocking material for nailers
9. Air sealing foam (one- or two-part SPF)
10. Belly repair tape

Paddle bits may be used to drill starter holes at the corners of the area to be patched. Cut the new patch 1/4" shorter than the hole in both length and width to allow room for expansion and contraction. Make sure to cut the patch so that the strength axis is perpendicular to the joists (the strong direction in plywood and OSB is parallel to the 8' length).

3.1301.2d - Floor repair



1 Carefully remove trim and floor coverings from area to be repaired



2 Mark the joist locations on either side of the damaged area



3 Cut out damaged area even with the inside edges of the floor joists



4 Cut four 2X4 blocks to support the patch



5 Install nailers flat against the joists. Finish by toenailing or screwing 2X4s between the joists

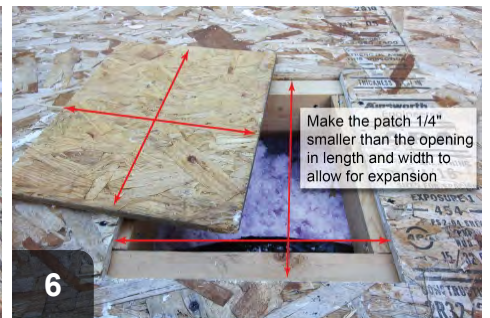

6 Make the patch 1/4" smaller than the opening in length and width to allow for expansion.

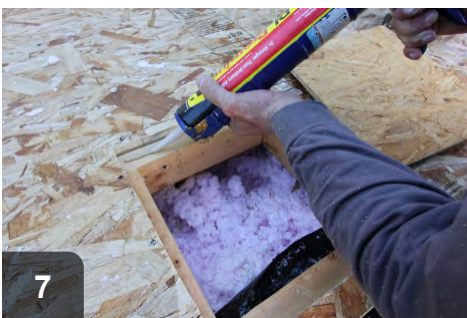

7 Apply subfloor adhesive to nailers



8 Make the patch 1/4" smaller than the opening in length and width to allow for expansion

Fasten with 2" deck screws

3.1301.2e

Desired Outcome:

Penetrations sealed to minimize air leakage and moisture movement between unconditioned and conditioned space; all repairs will maintain structural integrity

Specification(s):

Materials will be selected to comply with manufactured housing rules and regulations (e.g., Manufactured Housing Institute)

Materials will be used or installed in accordance with manufacturer specifications

Objective(s):

Select materials to ensure durable and permanent repair



Use materials with sufficient strength to span openings and support repair materials without bending or sagging

Tools:

1. Screw gun
2. Drill
3. Circular saw
4. Hammer or nail gun

Materials:

1. Typically 1X2, 1X4, 2X4, or 2X6 dimensional lumber. Steel angle may also be used to create sturdy repairs
2. Nails
3. Screws
4. Nuts, bolts, and washers
5. Staples

3.1301.2f

Desired Outcome:

Penetrations sealed to minimize air leakage and moisture movement between unconditioned and conditioned space; all repairs will maintain structural integrity

Specification(s):

Only noncombustible materials will be used in contact with chimneys, combustion exhaust vents, and flues

Objective(s):

Prevent a fire hazard



Gaps around floor penetrations allow air and moisture movement



Use non-combustible materials, like 26-gauge steel and high-temp caulk

Tools:

1. Drill/screwdriver
2. Caulk gun
3. Metal snips

Materials:

1. High-temperature caulk
2. Non-combustible material such as aluminum or galvanized steel flashing or cement board

3.1301.2f - High temperature application



1 Prepare work area by removing any insulation and debris



2 Use high-temperature caulking (600F min)



3 Apply first ring of caulking to match shape of opening



4 Apply second ring of caulking to size and shape of rigid material

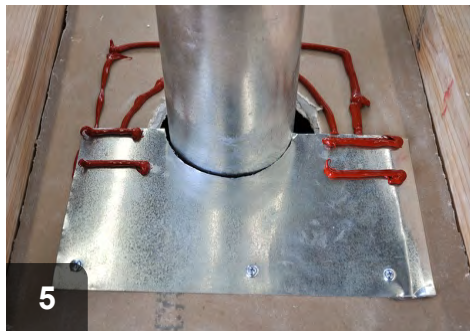

5 Fasten rigid material and apply additional caulking



6 Fasten rigid material to cover penetration and seal against flue with caulk

3.1302.1a

Desired Outcome:

Floor/framing around bay windows sealed and weathertight

Specification(s):

Installer prework assessment will be conducted to determine:

- Accessibility
- Number
- Type
- Size
- Operating condition
- Condition of opening
- Wall construction type

Objective(s):

Ensure work space is safe and ready for air sealing

Verify scope of work

3.1302.1b

Desired Outcome:

Floor/framing around bay windows sealed and weathertight

Specification(s):

Presence of lead-based paint in pre-1978 homes will be assumed unless testing confirms otherwise; documentation of testing results will be kept on file

EPA's Renovation, Repair and Painting (RRP) Program Rule (40 CFR Part 745) in pre-1978 homes and proposed changes to this rule (Federal Register/Vol. 75, No. 87/May 6, 2010) will be complied with, to be superseded by any subsequent final rulemaking or any more stringent state or federal standards

Objective(s):

Protect worker and occupant from potential lead hazards



Best Practice

In homes built before 1978, test paint before beginning renovation

Tools:

1. Note: Mask must be worn during testing
2. LeadCheck test kit
3. Utility knife
4. Camera

EPA RRP certification required to conduct Lead Paint assessment.

3.1302.1b - Lead paint assessment



1
Clean tools and sample site to prevent contamination



2
Cut sample site at an angle to expose all older paint layers



3
Break capsules and shake to mix reagents. Swab sample site for 30 seconds



4
Check swab for reaction



5
Red indicates lead positive. White indicates lead negative



6
If negative, verify validity of test with provided calibration card



7
Lead in calibration card should test positive and turn red

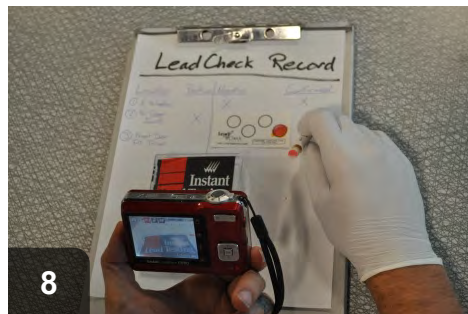

8
Record test results to maintain documentation

3.1302.1c

Desired Outcome:

Floor/framing around bay windows sealed and weathertight

Specification(s):

Details that reduce air infiltration will be repaired, replaced, sealed, or installed

Bay window floor framing that connects interior to exterior underpinning and insulation must be removed to seal gaps, cracks, and joints

Blocking must be installed on perimeter rail (rim joist) if missing

Seal all gaps, cracks, and joints of all framing in bay window assembly

Insulation must be replaced or installed in full contact with subfloor

Underpinning will be replaced and sealed

Objective(s):

Reduce air infiltration

3.1302.1d

Desired Outcome:

Floor/framing around bay windows sealed and weathertight

Specification(s):

Details that reduce water infiltration will be repaired, replaced, or installed

Objective(s):

Reduce water infiltration

3.1302.1e

Desired Outcome:

Floor/framing around bay windows sealed and weathertight

Specification(s):

Materials will be used or installed in accordance with product manufacturer specifications

Objective(s):

Ensure proper use and installation of materials

3.1488.2a

Desired Outcome:

Wind, weather, debris, and pests are excluded from the underside of the home

Specification(s):

Installer prework assessment will be conducted to determine:

- Type (ventilated or unventilated, insulated or noninsulated)
- Extent of repair/replacement
- Accessibility
- Moisture and drainage
- Structural integrity of foundation (e.g., piers and supports)
- Structural integrity of perimeter rail/rim joist
- Integrity of existing skirting support material
- Presence of infestation or pests

Problems will be corrected before skirting work begins

Objective(s):

Ensure work space is safe and ready for repair or installation

Verify scope of work

3.1488.2b

Desired Outcome:

Wind, weather, debris, and pests are excluded from the underside of the home

Specification(s):

Manufacturer specifications will be followed when applicable

No exposed wood will be left unfinished (e.g., wood to be painted, sealed, treated)

If framing is required for skirting, framing will be structurally sound

Skirting will be installed to allow for movement (e.g., no screws or nails directly through panels)

Skirting installation will allow for expansion, contraction, and frost heaving

Objective(s):

Match existing skirting

Provide resistance from outdoor elements

Limit pest access

3.1488.2c

Desired Outcome:

Wind, weather, debris, and pests are excluded from the underside of the home

Specification(s):

Venting will be in accordance with local climate conditions or code as required

Objective(s):

Achieve and maintain building durability

3.1488.2d

Desired Outcome:

Wind, weather, debris, and pests are excluded from the underside of the home

Specification(s):

Insulated skirting may be installed where belly is inaccessible and not repairable

Objective(s):

Reduce conductive heat loss through floor assembly

3.1488.2e

Desired Outcome:

Wind, weather, debris, and pests are excluded from the underside of the home

Specification(s):

Flashing or proper caulking will be installed between skirting and manufactured home, if required by authority having jurisdiction

Objective(s):

Prevent water penetration

3.1488.2f

Desired Outcome:

Wind, weather, debris, and pests are excluded from the underside of the home

Specification(s):

Like material and/or compatible materials will be used for repairs (e.g., galvanized metal, aluminum, alkaline copper quaternary treated lumber)

Selected materials will be corrosion resistant

Objective(s):

Achieve/increase durability

3.1488.2g

Desired Outcome:

Wind, weather, debris, and pests are excluded from the underside of the home

Specification(s):

Like material and/or compatible materials will be used for repairs (e.g., galvanized metal, aluminum, alkaline copper quaternary treated lumber)

Fasteners will be corrosion resistant

Objective(s):

Achieve/increase durability

3.1488.2h

Desired Outcome:

Wind, weather, debris, and pests are excluded from the underside of the home

Specification(s):

Existing skirting support material will be structurally sound and completely intact; any damaged framing will be replaced

Objective(s):

Provide adequate support

3.1488.2i

Desired Outcome:

Wind, weather, debris, and pests are excluded from the underside of the home

Specification(s):

Skirting support (e.g., vinyl blowout rods, horizontal bracing for other types) will be placed in high-wind locations

Objective(s):

Increase strength to resist wind loading

3.1488.2j

Desired Outcome:

Wind, weather, debris, and pests are excluded from the underside of the home

Specification(s):

Occupants will be educated on maintenance of skirting (e.g., floating panels are not tightly screwed to framing, string trimmers may damage skirting)

Objective(s):

Increase durability

3.1601.2a

Desired Outcome:

Condition of ductwork identified and necessary repairs made in preparation for spray polyurethane foam (SPF) application

Specification(s):

All exposed ductwork in unconditioned spaces (e.g., attics, basements, crawl spaces) will be inspected

Broken joints or large cracks, gaps, or holes will be identified

Type of ductwork (e.g., metal, duct board, flex duct) will be identified

Type and R-value of existing duct insulation (e.g., fiberglass, stone wool, asbestos) will be identified as will the location of vapor retarders, if any

If asbestos insulation was used, it will not be disturbed; consult with an asbestos abatement expert for removal

Loose fitting or damaged fiberglass or stone wool insulation will be removed using proper safety equipment

Necessary clearances for installation of SPF will be ensured

Objective(s):

Identify damaged ductwork in need of repair

Identify type and R-value of existing insulation

3.1601.2b

Desired Outcome:

Condition of ductwork identified and necessary repairs made in preparation for spray polyurethane foam (SPF) application

Specification(s):

Broken or missing ductwork will be repaired or replaced

All cracks, gaps, or holes greater than ¼" will be taped or sealed as feasible

Dust, dirt, and grease will be removed from exterior surfaces of ducts

Objective(s):

Cover openings in ducts to prevent SPF from entering the interior of the duct

Ensure surfaces of duct are clean to promote proper adhesion of SPF

3.1601.4a

Desired Outcome:

Ducts and plenums properly supported

Specification(s):

Flexible and duct board ducts and plenums will be supported where feasible in accordance with flex duct manufacturer specifications and local codes

Support materials will be applied in a way that does not crimp ductwork or cause the interior dimensions of the ductwork to be less than specified (e.g., ceiling, framing, strapping)

Metal ducts will be supported by metal strapping, rods, or other materials, where feasible

Objective(s):

Eliminate falling and sagging

3.1601.5a

Desired Outcome:

Ducts and plenums properly fastened to prevent leakage

Specification(s):

Surrounding insulation will be cleared to expose joints being sealed; salvage for reuse if possible

Duct surface to receive sealant will be cleaned

Objective(s):

Gain access while maintaining insulation value

Achieve proper adhesion for airtight seal when needed to ensure a tight fit to the framing structure and ensure the register can be removed and reinstalled by the dwelling occupant



Before

Locate disconnected or damaged ducts and clean work area of debris



In Progress

Clean surfaces to receive sealant. Allow to dry before applying sealant

Materials:

1. Cleaning solution or cleaning wipes

3.1601.5a - Preparation



When making connections at interior walls, mastic should be applied to boot and wall, and allowed to dry entirely

3.1601.5b

Desired Outcome:

Ducts and plenums properly fastened to prevent leakage

Specification(s):

Ducts will be fastened with a minimum of three equally spaced screws

Objective(s):

Ensure durable joints



 Before

Reconnect ducts that have come undone, using fasteners to strengthen connection

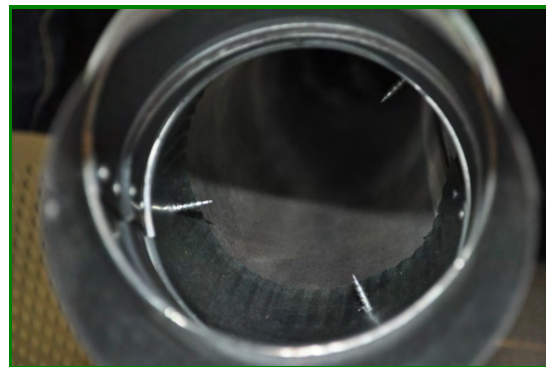

 After

At minimum, use three fasteners evenly spaced

Tools:

1. Drill

Materials:

1. Fasteners

3.1601.5b - Metal to metal



1
Realign and join ducts to create a smooth transition



2
Use fasteners to hold duct together and prevent future dislocation

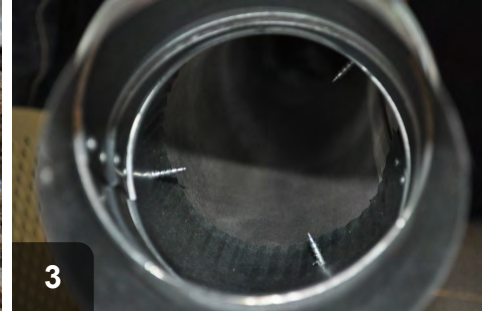

3
Attach ducts using a minimum of three, evenly-spaced fasteners

3.1601.5c

Desired Outcome:

Ducts and plenums properly fastened to prevent leakage

Specification(s):

Joints will be fastened with tie bands using a tie band tensioning tool

For oval flexible duct to metal connections, tie bands cannot be used; appropriate mechanical fastener will be used

All connections, regardless of fastener, will be sealed

Objective(s):

Ensure durable joints



 Before

Disconnected ducts are useless and need to be reconnected and securely fastened



 After

Flexible duct should be securely fastened to metal ducting to prevent future dislocation and minimize leakage

Tools:

1. Band tensioner
2. Brush

Materials:

1. Tie bands
2. Mastic or other appropriate sealant

3.1601.5c - Flex to metal



1 Apply mastic to flange



2 Slide inner liner onto flange with sealant



3 Using band tensioner, securely attach liner in place with tie band



4 Slide insulation and outer casing over metal ducting



5 Extend insulation and casing until in contact with other insulation



6 Secure insulation and casing in place using tie band and band tensioner

3.1601.5d

Desired Outcome:

Ducts and plenums properly fastened to prevent leakage

Specification(s):

Joints will be fastened with outward clinching (stitch) staples and c-channels if possible

Objective(s):

Ensure durable joints

3.1601.5e

Desired Outcome:

Ducts and plenums properly fastened to prevent leakage

Specification(s):

Metal take-off collar specifically designed for the thickness of the duct board will be used

All finger tabs will be bent down securely

Finger tabs will be longer than the thickness of the duct board and the shank will not extend beyond the thickness of the duct board

There will be an internal metal backer inside the duct board through which three evenly spaced screws can be secured; the metal backer will not interfere with air flow

Objective(s):

Ensure durable joints

Prevent the collar from moving into or out of the duct board or slipping



Bad Practice

Flex duct improperly attached to duct board.
No starting collar is installed.



Best Practice

Flex duct, starting collar, and backer ring installed and sealed to duct board

Tools:

1. Cordless driver/drill
2. 1/4" nut driver bit
3. Disposable brushes
4. Tin snips
5. Utility knife
6. Zip tie tensioning tool

Materials:

1. Galvanized metal backer rings
2. Tabbed starting collars
3. Rubber gloves
4. Zip ties
5. Duct sealing mastic
6. Fiberglass mesh tape

Make sure to use a starting collar that is made for the thickness of the duct board you are using. R-6 duct board is 1-1/2" thick. The correct starting collar would therefore have 1-1/2" of solid metal between the shoulder that fits against the outside of the duct board and the base of the tabs.

You may need to cut a slot in the duct board to slide the backer ring through. Use at least three equally spaced screws to fasten the starting collar to the backer ring.

3.1601.5e - Duct board to flexible duct



1 Gather materials



2 Place backer ring inside duct board. Insert collar and bend tabs into place.



3 Fasten the collar to the backer ring by driving at least three equally spaced screws through the collar, duct board



4 Coat joint between starting collar and duct board with mastic. Liberally coat the metal collar where flex attaches



5 Slide flex duct liner over mastic-coated metal collar



6 Secure with properly tensioned zip tie.



7 Coat seam with mastic



8 Pull insulation over duct liner and secure with a zip tie.

3.1601.5f

Desired Outcome:

Ducts and plenums properly fastened to prevent leakage

Specification(s):

Flange/c-channel will be fastened with screws with the duct board installed between c-channel flanges

Duct board plenum will be connected to air handler plenum with flexible duct in upflow units

Objective(s):

Ensure durable joints



Duct board plenum fastened with C-channel and screws

Tools:

1. Screw gun
2. Tin snips
3. Utility knife
4. Tape measure
5. Square

Materials:

1. Fiberglass duct board
2. C-channel (same width as duct board)
3. Sheet metal screws longer than the duct board thickness
4. Foil tape (for assembling duct board)
5. Mastic
6. Mesh tape (for gaps larger than 1/4")
7. Flex duct
8. Zip ties
9. Starting collar
10. Backing ring (fits inside duct board and fastens to starting collar)

3.1601.5g

Desired Outcome:

Ducts and plenums properly fastened to prevent leakage

Specification(s):

Predrill for screws or use ring shanked nails to fasten boot to wood

Objective(s):

Ensure durable joints



Unattached ducts are useless



Damaged ducts should be repaired and securely fastened and sealed

Tools:

1. Drill
2. Hammer

Materials:

1. Metal screws
2. Ring-shank nails

3.1601.5g - Boot to wood



Replace damaged ducting if necessary



Use ring-shank nails to hold ducting in place to subfloor



Drill pilot holes for metal fasteners



Use metal fasteners to secure duct to subfloor



After securely fastened, duct should be sealed with mesh and mastic

3.1601.5h

Desired Outcome:

Ducts and plenums properly fastened to prevent leakage

Specification(s):

If accessible, boot hanger will be fastened to adjacent framing with screws or nails

Boot will be connected to boot hanger with screws

If inaccessible, boot will be fastened to gypsum with a durable, adhesive sealant

Objective(s):

Ensure durable joints



Register boot fastened to framing and sealed to gypsum with spray foam

Tools:

1. Caulking gun or foam gun
2. Cordless driver/drill

Materials:

1. Polyurethane caulk
2. Mastic and mesh tape (for gaps larger than 1/4")
3. Screws
4. Fiberglass mesh tape (for gaps larger than 1/4")
5. Disposable brushes
6. Spray foam sealant

Fasten boot hangers to adjacent framing, or screw through the boot into adjacent framing. Polyurethane caulk is a durable adhesive, and can accommodate up to 50% expansion and

contraction. Mastic and mesh tape also form a strong, permanent seal. Spray foam may be used to seal boots into the opening once the boot is fastened in place

3.1601.5h - Boot to gypsum



Remove diffuser



Caulk the boot to the gypsum board. Angle the tip forward and force caulk into the joint



Wipe the caulk into the joint and smooth it as you go



Wipe away excess caulk (use water on siliconized acrylic, alcohol on silicone, and solvent on polyurethane caulk)

3.1601.5i

Desired Outcome:

Ducts and plenums properly fastened to prevent leakage

Specification(s):

Metal take-off collar with a lip and an internal metal backer will be used

Take-offs will be in accordance code requirements

Objective(s):

Ensure durable joints



Bad Practice

Improper attachment of flex to duct board



After

Flex duct correctly installed and sealed to duct board

3.1601.5i - Duct board to flex



Select a backer ring and flex duct installation tools



Cut the proper size hole in duct board



Select starting collar with tabs matching the thickness of the duct board



Insert the starting collar, bend tabs over and install at least 3 screws through the collar, duct board, and backer ring



Starting collar with tabs bent over and screws through the duct board and backer ring



Apply mastic liberally and install flex duct

3.1602.2a

Desired Outcome:

Exposed ductwork in unconditioned spaces insulated and sealed

Specification(s):

Insulation will be installed according to manufacturer specifications and all provisions of the 2012 IRC

SPF will be applied to desired thickness, using pass thickness maximum as indicated by manufacturer

Sufficient insulation will be applied to all joints and around all penetrations to the conditioned space through walls, floors, and ceilings

SPF will be covered with proper fire protective coverings or coatings appropriate for location of ductwork and type of foam used, and provisions of the 2012 IRC and local codes

If ducts are used for air-conditioning, an appropriate vapor retarder will be applied on the SPF if open-cell SPF used

If 2" or more of closed-cell SPF is used, follow manufacturer specification to determine if additional vapor retarder is needed

The flame spread index will not be greater than 25 and the smoke- developed index will not be greater than 450 at the specified installed thickness

The foam plastic will be protected with an ignition barrier

Objective(s):

Insulate and seal all exposed ductwork in unconditioned spaces

Manage moisture condensation on ductwork that carries cooled air in warm, moist climates

Provide adequate fire protection for exposed SPF

3.1602.3a

Desired Outcome:

Ducts and plenums sealed to prevent leakage

Specification(s):

Sealant will be applied in accordance with manufacturer specifications, as well as UL 181M, NFPA 90A, and NFPA 90B

Objective(s):

Reduce duct leakage

3.1602.8a

Desired Outcome:

Deliver all air from air handler to the trunk duct without leakage or restriction

Specification(s):

Installer prework assessment will be conducted to determine:

- Size of plenum
- Alignment
- Connection method
- Existing sealing

Objective(s):

Ensure an efficient and effective way to accomplish work

Verify scope of work

3.1602.8b

Desired Outcome:

Deliver all air from air handler to the trunk duct without leakage or restriction

Specification(s):

Debris will be removed

Surface will be prepared for work (e.g., remove tape, oil)

Floor will be prepared to receive the appropriately sized plenum

Objective(s):

Provide unobstructed path for work access and air flow

Ensure adhesion of materials to be installed

Provide a properly sized plenum to maximize distribution of air flow (equal to the furnace discharge)



Closet prepared for furnace installation

Tools:

1. Shop vac
2. Scraper
3. Bench duster
4. Dust pan

Materials:

1. Rags

3.1602.8b - Preparation



Dust walls and floor of cabinet. Sweep debris into piles for pickup. Wipe down walls and floor



Vacuum cabinet clean



Inspect plenum for damage, then clean, scrape, and seal



Scrape loose material from insides of cabinet



Apply mastic to inside seams of plenum

3.1602.8c

Desired Outcome:

Deliver all air from air handler to the trunk duct without leakage or restriction

Specification(s):

Plenum will be rebuilt or repaired using compatible materials and will be:

- Mechanically fastened
- Sealed
- Durable
- Structurally sound
- Insulated
- Equipped with a vapor retarder where climate appropriate

If possible, flow diverter or turning vanes will be installed for air flow and/or balancing (e.g., bullhead Ts, offset air handler)

Objective(s):

Minimize restrictions

Maximize air flow and air distribution

Minimize moisture issues

Prevent condensation on plenum

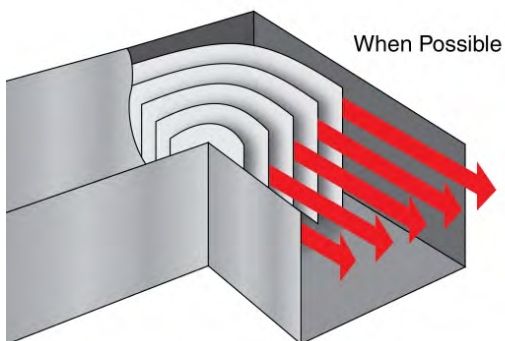

Best Practice

Whenever possible, install turning vanes in plenums to reduce turbulence and improve airflow



In Progress

Rebuilding and sealing a leaky existing plenum

Materials:

1. Starting collars and flanges
2. Zip ties
3. Mastic duct sealant
4. Fiberglass mesh tape
5. Sheet metal screws
6. Turning vanes
7. Duct board

Using turning vanes reduces turbulence and increases air flow. Use mastic and mesh tape on the outside of duct board plenums. Properly install metal starting collars to duct board and flex duct to metal collars (see spec 3.1601.5e for detail)

3.1602.8d

Desired Outcome:

Deliver all air from air handler to the trunk duct without leakage or restriction

Specification(s):

Point of access options include:

Option 1: Through the trunk duct

- Repair and seal access hole in the trunk duct
- Install insulation
- Repair belly/bottom liner

Option 2: Remove crossover duct

- Reattach crossover duct
- Seal and insulate crossover duct
- Repair belly/bottom liner

Option 3: Remove air handler

- Install new gasket, if necessary
- Mechanically attach furnace to the structure
- Reconnect utilities
- Replace and seal panels

Option 4: Through the furnace panel

- Replace and seal panels

Objective(s):

Repair work access

Prevent condensation

Minimize heat loss and heat gain from plenum



Various methods can be employed, but the key is to seal the furnace to trunk duct connection

Tools:

1. Utility knife
2. Saw
3. Prybar
4. Screw gun
5. Hammer
6. Drill
7. Saw
8. Disposable brushes

Materials:

1. Belly repair tape
2. Mastic duct sealant
3. Fiberglass mesh tape
4. Insulation
5. Air handler gasket

Choose the least invasive and labor-intensive method that will allow full access for sealing.

Always wear hand protection when working with sharp objects.

3.1602.8d - Repair work access



Cut belly to expose duct trunk. Use a utility knife to cut access under furnace plenum

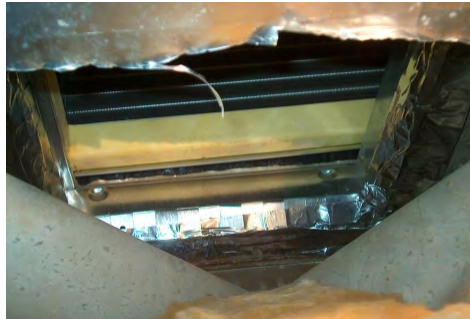

Create an opening large enough to completely seal the plenum to the trunk line



Using mastic and mesh tape, fully seal the furnace to the trunk line. Repair and seal the access holes in duct and belly



Removing the crossover duct may provide access to the plenum. Replace and seal the crossover duct after sealing plenum



Remove the furnace panel. If the plenum to trunk connection is accessible here, complete sealing from this point



Plenum to duct trunk connection coated with mastic sealant

3.1602.8e

Desired Outcome:

Deliver all air from air handler to the trunk duct without leakage or restriction

Specification(s):

Equipment will be cycled

Combustion Appliance Zone (CAZ) test will be performed where combustion appliances are utilized

Objective(s):

Verify operation

Identify unsafe equipment operating conditions



Conduct spillage and depressurization testing at the end of the work day

Tools:

1. Manometer
2. Smoke pencil
3. Mirror
4. Stopwatch or watch with second hand

3.1602.8e - Safety testing

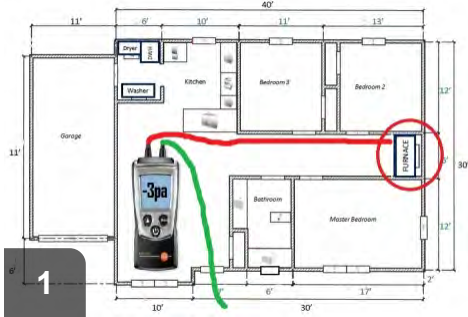

1 Run depressurization test at the end of the work day



2 Complete spillage test using chemical smoke pencil or mirror



3 Test for spillage on all sides of draft diverter. Check spillage on all atmospheric combustion appliances



4 Check carbon monoxide levels on all combustion appliances, including direct vent equipment



5 Check carbon monoxide levels on all combustion appliances

3.1602.8f

Desired Outcome:

Deliver all air from air handler to the trunk duct without leakage or restriction

Specification(s):

Pre- and post-retrofit duct leakage will be performance tested using a duct blaster or pressure pan, and results will be documented and reported to the homeowner and/or program

Objective(s):

Document post-retrofit duct leakage test has been performed



Best Practice

Test duct performance using pressure pan or duct blaster, before and after work



Best Practice

Record readings before and after to determine improvement in performance

Tools:

1. Duct blaster
2. Blower door
3. Manometer
4. Pressure Pan

Materials:

1. Duct mask

3.1602.8f - Performance testing



Perform duct blaster testing before beginning work. Record results



Perform duct blaster testing after completion of work and compare to 'before' reading. Record results



Set-up blower door to perform pressure pan testing before and after work



Perform pressure pan test on ductwork before beginning work. Record result



Perform pressure pan test after work is completed and compare to 'before' reading



Record test results to determine improvement of performance

3.1602.9a

Desired Outcome:

Deliver all air from trunk to trunk without leakage or restriction

Specification(s):

Installer prework assessment will be conducted to determine:

- Location
- Types
- Leakage points

Objective(s):

Verify scope of work



Locate the best access and egress points



Locate crossover duct and determine what type of system will work best for home

3.1602.9b

Desired Outcome:

Deliver all air from trunk to trunk without leakage or restriction

Specification(s):

Flexible crossover duct connections will be added, rebuilt, or repaired using compatible materials and will be:

- Mechanically fastened at both inner and outer liner
- Sealed using UL-listed sealant that is durable, structurally sound, insulated
- Equipped with a vapor retarder

Whenever possible, rigid elbow or equivalent will be installed in crawl space crossover ducts

Floor insulation will be in contact with the outer liner of the crossover duct

Crossover duct vapor retarder will be sealed to the bottom liner (e.g., belly fabric)

New flex duct installation will be insulated to a minimum of R-8

When feasible, 26-gauge hard duct should be installed

If a new crossover is required, it must be insulated to at least R-8 and be air sealed

Objective(s):

Ensure lasting durable connections

Minimize air leakage and heat transfer

Maintain duct diameter around the turns

Maximize air flow and distribution



 Before

Unattached ducts are useless



 After

Crossover ducts should be attached securely, sealed to reduce leakage, and insulated to R-8

Tools:

1. Band tensioner
2. Drill
3. Brush

Materials:

1. Tie bands
2. Mastic or other appropriate sealant
3. 26 gauge elbow duct
4. R-8 insulated flexible duct with vapor retarder

3.1602.9b - Flexible crossover duct connections



1 Attach elbow duct and orient in correct direction to minimize duct run



2 Fasten elbow in place with at least three evenly-spaced fasteners



3 Apply mastic at metal-to-metal connection



4 Apply mastic to all elbow joints and flange



5 Slide inner liner onto flange with sealant



6 Fasten inner inner with tie band using band tensioner

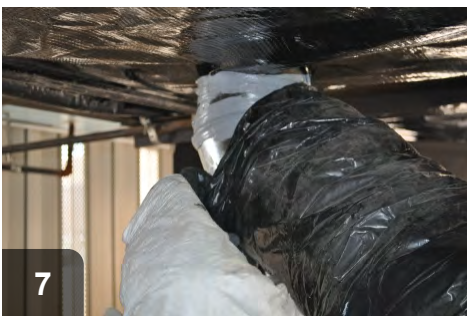

7 Extend insulation and exterior casing up over elbow until they reach belly



8 Secure insulation and outer casing place with tie band



9 Use band tensioner to ensure that insulation and casing remain tight against belly

3.1602.9c

Desired Outcome:

Deliver all air from trunk to trunk without leakage or restriction

Specification(s):

Crossover ducts will be installed so they are not in contact with the ground

Crossover ducts will be supported in accordance with flex duct manufacturer specifications, local codes

Support materials will be applied in accordance with manufacturer specifications for interior dimensions and will not crimp ductwork, dip, or sag

Objective(s):

Maximize air flow and distribution

Minimize condensation

Minimize air leakage and heat transfer



 Before

Flexible ducting should not come in contact with ground



 After

Supports should be evenly spaced, securely fastened to floor joists and should not compress or kink duct

Tools:

1. Drill
2. Utility knife

Materials:

1. Fabric straps
2. Fasteners

3.1602.9d

Desired Outcome:

Deliver all air from trunk to trunk without leakage or restriction

Specification(s):

Through-the-rim crossover ducts will be located and accessed through the bottom liner and branch duct; all branch crossover duct connections and end caps will be located and accessed

Hole size (air pathway) will be maximized between branch crossover and trunk

All connections will be mechanically fastened and sealed inside duct

End caps will be sealed

Objective(s):

Ensure all connections are identified

Maximize air flow and distribution

Ensure lasting durable connections

Minimize air leakage

3.1602.9e

Desired Outcome:

Deliver all air from trunk to trunk without leakage or restriction

Specification(s):

Access hole in the trunk duct will be repaired and sealed

Insulation will be reinstalled

Bottom liner/belly will be repaired

Objective(s):

Repair work access

Minimize heat transfer

3.1602.9f

Desired Outcome:

Deliver all air from trunk to trunk without leakage or restriction

Specification(s):

Access to the attic will be created for all attic areas that contain crossover ducts, where feasible

Plenum boxes and crossover duct connections will be rebuilt, mechanically fastened, and sealed

Access holes will be repaired

Objective(s):

Ensure lasting durable connections

Minimize air leakage

Maximize air flow and distribution

Repair work access

3.1602.9g

Desired Outcome:

Deliver all air from trunk to trunk without leakage or restriction

Specification(s):

CAZ testing will be performed where combustion appliances are utilized

Objective(s):

Identify unsafe equipment operating conditions



Complete combustion appliance zone testing to ensure a healthy, safe environment

See
**SWS 2.0201.3a-
2.0201.3h
for CAZ testing**

Tools:

1. Manometer
2. Mirror
3. Chemical smoke puffer
4. Stopwatch or watch with second hand
5. Gas leak detector
6. Combustion analyzer
7. 1/4" air line tubing

At the end of each day in which duct sealing or repair is performed, conduct Combustion Appliance Zone (CAZ) testing in accordance with the NREL Manufactured Home Standard Work Specifications, details 2.0201.3a through 2.0201.3h.

3.1602.9h

Desired Outcome:

Deliver all air from trunk to trunk without leakage or restriction

Specification(s):

Pre- and post-retrofit duct leakage will be performance tested using a duct blaster or pressure pan, and results will be documented and reported to the homeowner and/or program

Objective(s):

Document post-retrofit duct leakage test has been performed



Best Practice

Test duct performance using pressure pan or duct blaster, before and after work



Best Practice

Record readings before and after to determine improvement in performance

Tools:

1. Duct blaster
2. Blower door
3. Manometer
4. Pressure Pan

Materials:

1. Duct mask

3.1602.9h - Performance testing



Run duct blaster test before beginning work and record result



Run duct blaster test after work and compare with 'before' reading. Record result



Set-up blower door to perform pressure pan testing



Perform pressure pan test on ductwork before beginning work. Record result



Perform pressure pan test after work is completed and compare to 'before' reading



Record readings before and after to determine if performance has improved

3.1602.10a

Desired Outcome:

Deliver air from trunk to termination (register/diffuser) without leakage

Specification(s):

Installer prework assessment will be conducted to determine:

- Location
- Connection types
- Leakage points

Access holes will be created for the work done at each location

Objective(s):

Verify scope of work

Gain access to duct connections

3.1602.10b

Desired Outcome:

Deliver air from trunk to termination (register/diffuser) without leakage

Specification(s):

Excess flex duct will be removed between the takeoff at trunk and floor register boot

Objective(s):

Improve air flow



 Before

This duct is far too long, resulting in poor airflow.



 After

The duct has been shortened, and is now properly supported.

3.1602.10c

Desired Outcome:

Deliver air from trunk to termination (register/diffuser) without leakage

Specification(s):

Hard and flex duct branch connections will be rebuilt or repaired using compatible materials and will be mechanically fastened and sealed

Ends will be sealed

Objective(s):

Ensure lasting durable connections

Minimize air leakage

Maximize air flow and distribution



In Progress

Here the worker is rebuilding a hard connection to the trunk line.



After

The duct has been sealed, ensuring proper airflow to the home.

Tools:

1. drill
2. tin snips
3. inspection mirror
4. utility knife

Materials:

1. metal boot material
2. mesh tape
3. mastic
4. replacement grille

3.1602.10c - Duct connection repairs



Measure the dimensions required for the new boot.



Fit the new boot on to the trunk line.



Seal the boot to the trunk line using mastic and mesh tape. An inspection mirror can make this easier.



Mechanically fasten the boot to the subfloor.

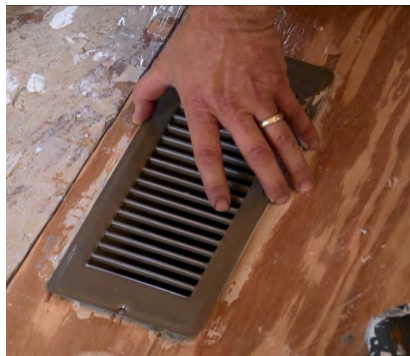

Install a new grille on the rebuilt boot.

3.1602.10d

Desired Outcome:

Deliver air from trunk to termination (register/diffuser) without leakage

Specification(s):

Access hole in the trunk/branch duct will be repaired and sealed

Insulation will be reinstalled

Bottom liner/belly will be repaired

Objective(s):

Repair work access

Minimize heat transfer



Access hole cut into manufactured home branch duct



Repaired, insulated, and sealed access hole in manufactured home duct and belly

Tools:

1. Utility knife
2. Disposable brushes
3. Outward clinching stapler
4. Scissors

Materials:

1. Fiberglass mesh tape
2. Mastic duct sealant
3. Foil tape
4. Insulation
5. Belly repair tape
6. Belly wrap
7. Staples
8. Solvent (acetone, paint thinner, denatured alcohol, Goof-Off, or similar) to clean aluminum duct
9. Spray adhesive for belly repairs

3.1602.10d - Repair work access



Thoroughly clean duct with solvent before applying foil tape and mastic

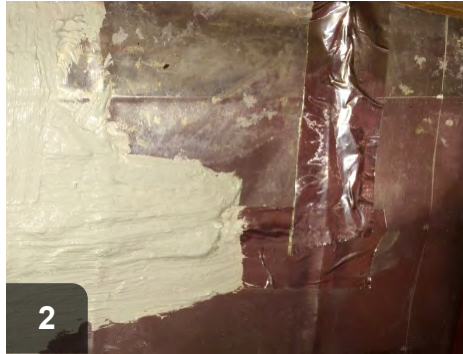

Secure edges of repair with foil tape and then liberally coat with mastic



Overlap foil tape with mastic by at least one inch on all sides



Replace or reinstall fiberglass belly insulation



Apply belly repair tape and fasten with outward clinching (stitch) staples. Spray adhesive will help adhere the tape

3.1602.10e

Desired Outcome:

Deliver air from trunk to termination (register/diffuser) without leakage

Specification(s):

CAZ testing will be performed where combustion appliances are utilized

Objective(s):

Identify unsafe equipment operating conditions

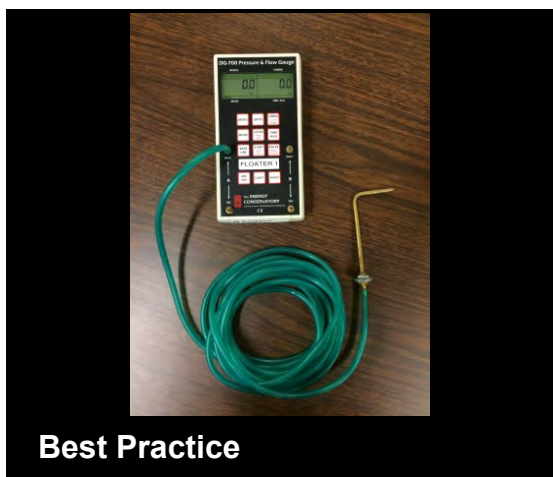

Complete combustion appliance zone testing to ensure a healthy, safe environment

Tools:

1. Manometer
2. Mirror
3. Chemical smoke pencil
4. Gas leak detector
5. Combustion analyzer
6. Stopwatch
7. 1/4" air line tubing

At the end of each day in which duct sealing or repair is performed, conduct Combustion Appliance Zone (CAZ) testing in accordance with the NREL Manufactured Home Standard Work Specifications, details 2.0201.3a through 2.0201.3h.

See
**SWS 2.0201.3a-
2.0201.3h
for CAZ testing**

3.1602.10f

Desired Outcome:

Deliver air from trunk to termination (register/diffuser) without leakage

Specification(s):

Pre- and post-retrofit duct leakage will be performance tested using a duct blaster or pressure pan, and results will be documented and reported to the homeowner and/or program

Objective(s):

Document post-retrofit duct leakage test has been performed



Best Practice

Test duct performance using pressure pan or duct blaster, before and after work



Best Practice

Record readings before and after to determine improvement in performance

Tools:

1. Duct blaster
2. Blower door
3. Manometer
4. Pressure Pan

Materials:

1. Duct mask

3.1602.10f - Performance testing



Perform duct blaster testing before beginning work. Record results



Perform duct blaster testing after completion of work and compare to 'before' reading. Record results



Set-up blower door to perform pressure pan testing before and after work



Perform pressure pan test on ductwork before beginning work. Record result



Perform pressure pan test after work is completed and compare to 'before' reading

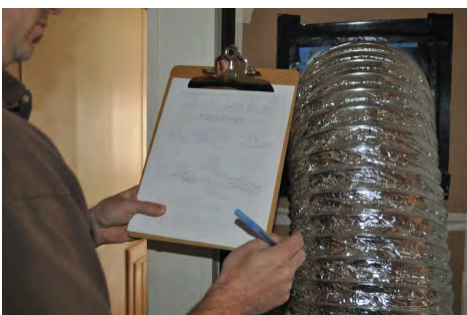

Record test results to determine improvement of performance

3.1602.11a

Desired Outcome:

Ducts and plenums sealed to prevent leakage

Specification(s):

Any closure system used will meet or exceed applicable standards

Objective(s):

Ensure effectiveness of air sealing system

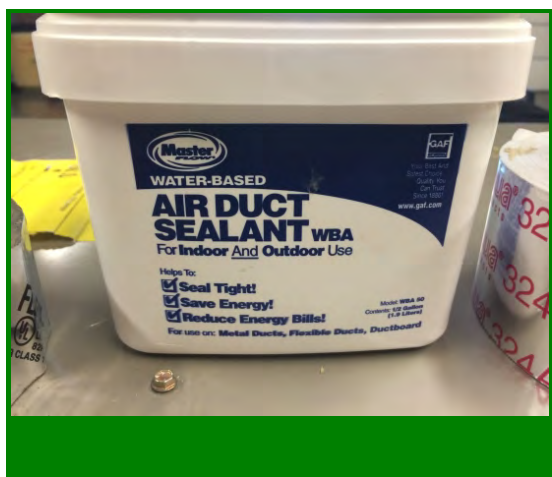

Mastic sealant is an approved, durable, and effective sealant

Tools:

1. Utility knife
2. Disposable brushes

Materials:

1. UL 181 B-FX tape (cover with mastic after assembly)
2. Fiberglass mesh tape (use, along with mastic, to cover gaps wider than 1/4-inch and to add strength to assemblies)
3. Mastic (air duct sealant) labeled UL 181 B-M
4. Spray polyurethane foam

Per the 2012 IRC, use tape labeled 181 B-FX and/or mastic labeled 181 BM. Seal and mechanically fasten all duct connections to metal flanges. Fasten round metal ducts with at least three screws equally spaced around the diameter, and make sure that the ducts and fittings are inserted at least 1". DO NOT USE unlisted duct tape as a sealant on any duct.

Exceptions:

1. Spray polyurethane foam shall be permitted to be applied without additional joint seals.

2. Where a duct connection is made that is partially inaccessible, three screws or rivets shall be equally spaced on the exposed portion of the joint so as to prevent a hinge effect.
3. Continuously welded and locking-type longitudinal joints and seams in ducts operating at static pressures less than 2 inches of water column (500 Pa) pressure classification shall not require additional closure systems. "

3.1602.11a - New component to new component sealant selection



Use fiberglass mesh tape to cover gaps; coat with at least 2mm of mastic



Coat seams with mastic (air duct sealant) conforming to standard UL 181 B-M

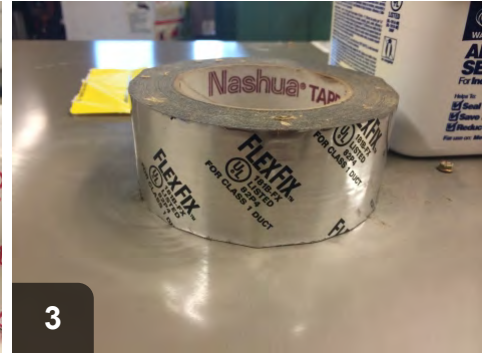

Use tape to assemble joints, then coat with at least 2mm of mastic

3.1602.11b

Desired Outcome:

Ducts and plenums sealed to prevent leakage

Specification(s):

Duct surface to receive sealant will be cleaned

Seams, cracks, joints, holes, and penetrations less than ¼" will be sealed using fiberglass mesh and mastic

Mastic alone will be acceptable for holes less than ¼" that are more than 10' from air handler

Holes greater than ¾" will be patched with metal or joint will be rebuilt to reduce the gap size

Seams, cracks, joints, holes, and penetrations between ¼" and ¾" will be sealed in two stages:

- They will be backed using temporary tape (e.g., foil tape) as a support before sealing
- They will be sealed using fiberglass mesh and mastic

Objective(s):

Eliminate air leakage into or out of ducts and plenums

Ensure adhesion of primary seal (fiberglass mesh and mastic) to the duct

Reinforce seal

Support mastic and fiberglass mesh during curing



Unsealed metal ductwork



Mastic and mesh tape used to seal metal ductwork

Tools:

1. Zip tie tensioning tool
2. Utility knife
3. Disposable brushes
4. Tin snips
5. Screw gun

Materials:

1. Mastic
2. Fiberglass mesh tape
3. Metal starting collar
4. Foil tape
5. Sheet metal

3.1602.11b - New component to existing component



1 Fasten collar into plenum with screws that reach through the tabs and plenum into a backing ring. Apply mastic liberally



2 Apply mastic to metal collar



3 Install duct liner onto collar and secure with properly tensioned zip tie

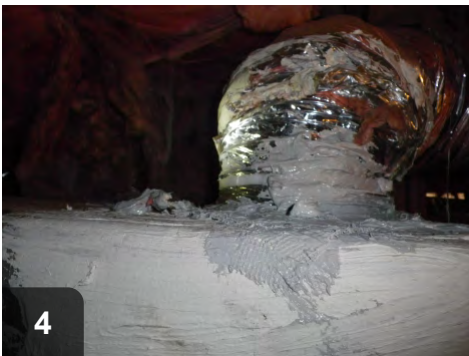

4 Apply additional mastic over zip tie and edge of flex duct liner

3.1602.11c

Desired Outcome:

Ducts and plenums sealed to prevent leakage

Specification(s):

Duct surface to receive sealant will be cleaned

Fiberglass mesh and mastic will overlap temporary tape by at least 1" on all sides

Seams, cracks, joints, holes, and penetrations larger than $\frac{3}{4}$ " will be repaired using rigid duct material

Fiberglass mesh and mastic will overlap repair joint by at least 1" on all sides

Fiberglass mesh and mastic will be the primary seal

Objective(s):

Eliminate air leakage into or out of ducts and plenums

Ensure adhesion of primary seal (fiberglass mesh and mastic) to the duct

Reinforce seal

Support mastic and fiberglass mesh during curing

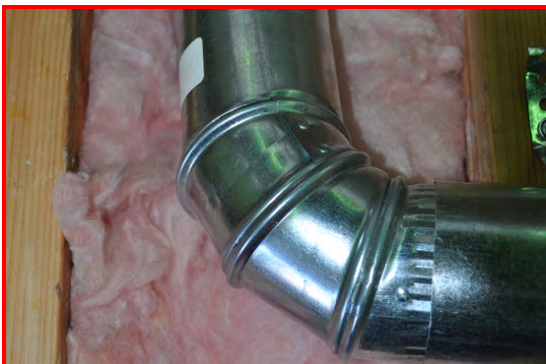

 Before

Unsealed joints and connections need to be sealed to stop air leaks, improve durability, and minimize health risks



 After

Sealed ductwork connections help prevent leakage

Tools:

1. Brush

Materials:

1. Mastic
2. Fiberglass mesh tape

3.1602.11c - Existing component to existing component



1 Prepare work area by assessing any safety concerns and cleaning duct surface

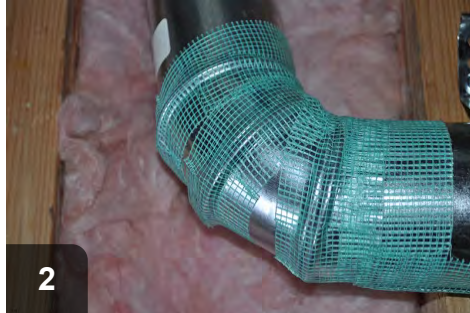

2 Wrap joint with fiberglass mesh tape



3 Apply UL 181 mastic to seal joint

3.1602.11d

Desired Outcome:

Ducts and plenums sealed to prevent leakage

Specification(s):

Pre- and post-retrofit duct leakage will be performance tested using a duct blaster or pressure pan, and results will be documented and reported to the homeowner and/or program

Objective(s):

Document post-retrofit duct leakage performed



Best Practice

Test duct performance using pressure pan or duct blaster, before and after work



Best Practice

Record readings before and after to determine improvement in performance

Tools:

1. Duct blaster
2. Blower door
3. Manometer
4. Pressure Pan

Materials:

1. Duct mask

3.1602.11d - Performance testing



Perform duct blaster testing before beginning work. Record results



Perform duct blaster testing after completion of work and compare to 'before' reading. Record results



Set-up blower door to perform pressure pan testing



Perform pressure pan test on ductwork before beginning work. Record result



Perform pressure pan test after work is completed and compare to 'before' reading

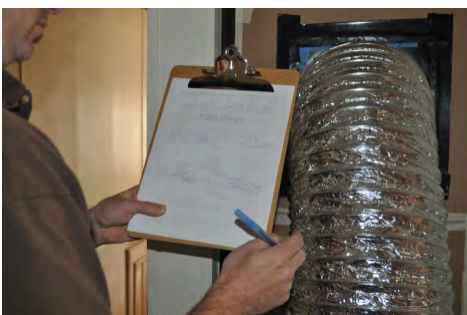

Record test results to determine improvement of performance

3.1602.12a

Desired Outcome:

Ducts and plenums sealed to prevent leakage

Specification(s):

Gaps between boot and gypsum less than a ¼" will be sealed using mastic or appropriate flexible caulking

Gypsum edge will be wetted before applying mastic

Objective(s):

Prevent air leakage



 Before

Gaps around duct boots allow for leakage to and from the attic



 After

Use a mesh in mastic system to seal duct boot to interior surface

Tools:

1. Utility knife
2. Spray bottle
3. Putty knife

Materials:

1. Mastic
2. Fiberglass mesh tape

3.1602.12a - Duct boot to interior surface



1
Remove grill to expose duct boot and gaps



2
Wet the edges of the drywall to ensure a good bond



3
Cut mesh tape to fit around duct boot and cover gaps



4
Apply mastic over mesh tape to create heat resistant, durable bond

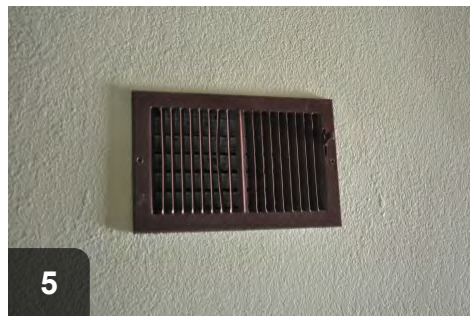

5
Once mastic is set, grill can be replaced and mastic should not show

3.1602.12b

Desired Outcome:

Ducts and plenums sealed to prevent leakage

Specification(s):

Joints will be sealed and cracks/holes not needed for proper function of unit will be sealed using removable sealant (e.g., foil tape)

Objective(s):

Reduce air leakage while maintaining accessibility



Unnecessary holes in the air handler cabinet need to be sealed

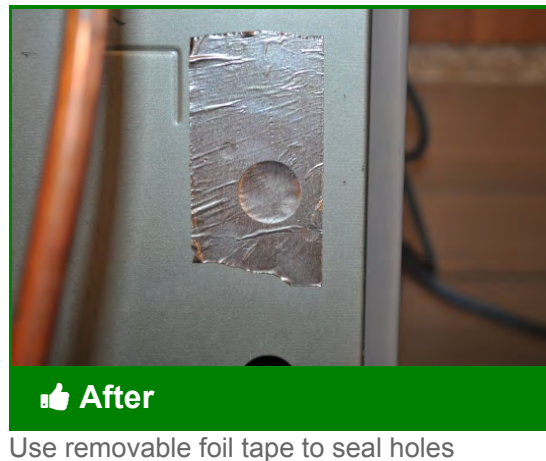

Materials:

1. Foil tape

3.1602.12b - Air handler cabinet outside conditioned space



1
Unnecessary holes in the air handler cabinet should be sealed



2
Removable foil tape should be used to seal



3
Fully cover holes with tape to seal completely

3.1602.12c

Desired Outcome:

Ducts and plenums sealed to prevent leakage

Specification(s):

Pre- and post-retrofit duct leakage will be performance tested using a duct blaster or pressure pan, and results will be documented and reported to the homeowner and/or program

Objective(s):

Document post-retrofit duct leakage test has been performed



Best Practice

Test duct performance using pressure pan or duct blaster, before and after work



Best Practice

Record readings before and after to determine improvement in performance

Tools:

1. Duct blaster
2. Blower door
3. Manometer
4. Pressure Pan

Materials:

1. Duct mask

3.1602.12c - Performance testing



Perform duct blaster testing before beginning work. Record results



Perform duct blaster testing after completion of work and compare to 'before' reading. Record results



Set-up blower door to perform pressure pan testing before and after work



Perform pressure pan test on ductwork before beginning work. Record result



Perform pressure pan test after work is completed and compare to 'before' reading

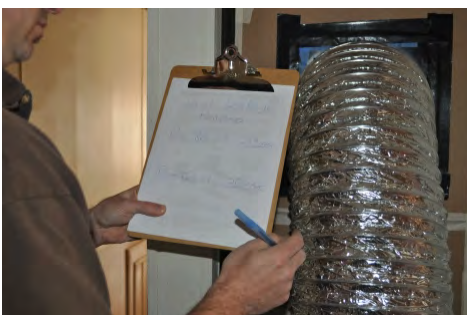

Record test results to determine improvement of performance

3.1602.13a

Desired Outcome:

The return duct is installed to prevent air leakage

Specification(s):

Debris and dirt will be cleaned out of the return platform

Objective(s):

Allow for the application of rigid materials and sealants



Dirty, unsealed return platform needs to be cleaned out before sealing



Vacuum out debris and dirt from the return to prepare work area

Tools:

1. Shop vacuum

3.1602.13b

Desired Outcome:

The return duct is installed to prevent air leakage

Specification(s):

Backing or infill will be provided as needed to meet the specific characteristics of the selected material and the characteristics of the open space

Backing or infill will not bend, sag, or move once installed

Material will be rated for use in return duct systems

Objective(s):

Minimize hole size to ensure successful use of sealant

Ensure closure is permanent and supports all loads (e.g., return air pressure)

Ensure sealant does not fall out



Before

Leakage from air return into wall cavities should be eliminated



In Progress

Only materials rated for use in higher temperature areas should be used

Tools:

1. Tape measure
2. Utility knife
3. Drill
4. Caulk gun

Materials:

1. XPS
2. Drywall
3. Fire-resistant caulk
4. Fasteners

3.1602.13b - Infill and backing



Do NOT use EPS in air returns due to proximity to combustion appliances

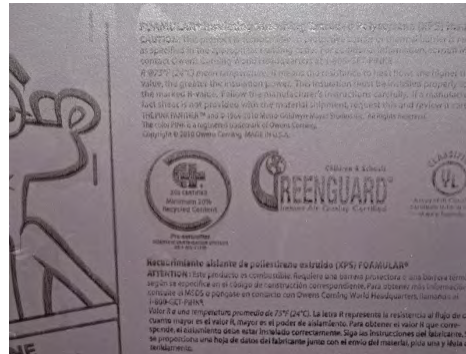

XPS (extruded polystyrene) and drywall are safe for use in air returns

3.1602.13c

Desired Outcome:

The return duct is installed to prevent air leakage

Specification(s):

Sealants will be compatible with their intended surfaces

Sealants will be continuous and meet fire barrier specifications

Objective(s):

Select permanent sealant

Ensure sealant meets or exceeds the performance characteristics of the surrounding materials



Best Practice

Sealants, like mesh and UL 181 mastic, meet IRC, ASTM, and UL specs



Best Practice

Caulk sealants will be continuous and compatible with surface

Tools:

1. Caulk gun
2. Utility knife
3. Taping knife

Materials:

1. Fiberglass mesh
2. Siliconized caulk
3. UL 181 mastic

Paraphrased from 2012 IRC R302.9: Wall and ceiling finishes will have a flame spread index of 200 or less and a smoke-developed index of 450 or less

3.1701.1a

Desired Outcome:

The exterior of the seam is weathertight and connection between house and addition is properly sealed to minimize air leakage and moisture movement between unconditioned and conditioned space

Specification(s):

Installer prework assessment will be conducted to determine:

- Structural integrity
- Roof leaks
- Insect infestation
- Accessibility
- Mechanical attachment
- Location of marriage wall seams
- Number, type, size, and location of penetrations

Objective(s):

Ensure work space is safe and ready for air sealing

Verify scope of work

3.1701.1b

Desired Outcome:

The exterior of the seam is weathertight and connection between house and addition is properly sealed to minimize air leakage and moisture movement between unconditioned and conditioned space

Specification(s):

Marriage wall seams will be sealed continuously at walls, floors, and ceiling connection

All accessible holes and penetrations in the addition envelope will be sealed

Backing or infill will be provided as needed, when accessible

Objective(s):

Minimize air leakage

Maintain durability and/or flexibility

Ensure sealant is effective and durable

3.1701.1c

Desired Outcome:

The exterior of the seam is weathertight and connection between house and addition is properly sealed to minimize air leakage and moisture movement between unconditioned and conditioned space

Specification(s):

Materials will be used or installed in accordance with product manufacturer specifications

Objective(s):

Select materials to ensure durable and permanent repair

3.1701.1d

Desired Outcome:

The exterior of the seam is weathertight and connection between house and addition is properly sealed to minimize air leakage and moisture movement between unconditioned and conditioned space

Specification(s):

All holes and penetrations on exterior surface of exterior walls will be sealed to ensure resistance to outdoor elements

Intentionally ventilated walls will not be sealed at vent locations (e.g., weep holes)

All holes and penetrations on the interior surface of exterior walls will be repaired

Backing or infill will be provided as needed to meet the specific characteristics of the selected sealant and the characteristics of the penetration

Objective(s):

Minimize air leakage

Maintain durability

Ensure resulting closure is permanent and supports expected wind and mechanical pressure loads

Ensure sealant is effective and durable

3.1701.1e

Desired Outcome:

The exterior of the seam is weathertight and connection between house and addition is properly sealed to minimize air leakage and moisture movement between unconditioned and conditioned space

Specification(s):

All accessible holes and penetrations in top and bottom plates will be sealed

Backing or infill will be provided as needed to meet the specific characteristics of the selected sealant and the characteristics of the penetration

Objective(s):

Minimize air leakage

Maintain durability

Ensure resulting closure is permanent and supports expected load

Ensure sealant is effective and durable

3.1701.1f

Desired Outcome:

The exterior of the seam is weathertight and connection between house and addition is properly sealed to minimize air leakage and moisture movement between unconditioned and conditioned space

Specification(s):

Backing or infill will be provided as needed to meet the specific characteristics of the selected sealant and the characteristics of the penetration

The backing or infill will not bend, sag, or move once installed

Objective(s):

Ensure resulting closure is permanent and supports expected wind and mechanical pressure loads

Ensure sealant is effective and durable

3.1701.1g

Desired Outcome:

The exterior of the seam is weathertight and connection between house and addition is properly sealed to minimize air leakage and moisture movement between unconditioned and conditioned space

Specification(s):

Sealants will be used to fill holes no larger than recommended by manufacturer specifications

Sealants will be compatible with all adjoining surfaces

Sealants will be continuous and meet fire barrier specifications, if required

Objective(s):

Create a permanent seal

Ensure sealant meets or exceeds the performance characteristics of the surrounding materials

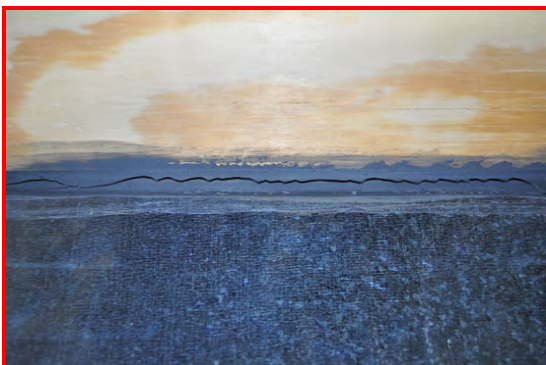

Bad Practice

Avoid sealants that do not allow for expansion between dissimilar materials



Best Practice

Flexible sealants compensate for differential expansion and maintain a seal

Tools:

1. Caulk gun
2. Spray foam gun

Materials:

1. Caulk
2. Spray foam

3.1701.1g - Sealant selection



Caulking can be used to span gaps up to 1/4 inch



Spray foam can be used to span gaps up to 3 inches

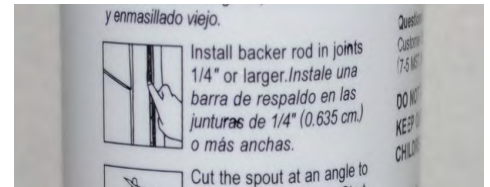

Check manufacturer specifications to verify spanning capabilities

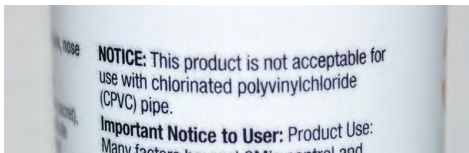

Also check manufacturer specs for incompatibility with intended surfaces

3.1701.1h

Desired Outcome:

The exterior of the seam is weathertight and connection between house and addition is properly sealed to minimize air leakage and moisture movement between unconditioned and conditioned space

Specification(s):

Floor repair material will meet or exceed strength of existing floor material

Repair will span from joist to joist and blocking added as needed to support floor

Patches smaller than 144 square inches will not require repairs from joist to joist

Floor repair material will be glued, fastened, and air sealed

Objective(s):

Ensure floor is structurally sound

Minimize air leakage

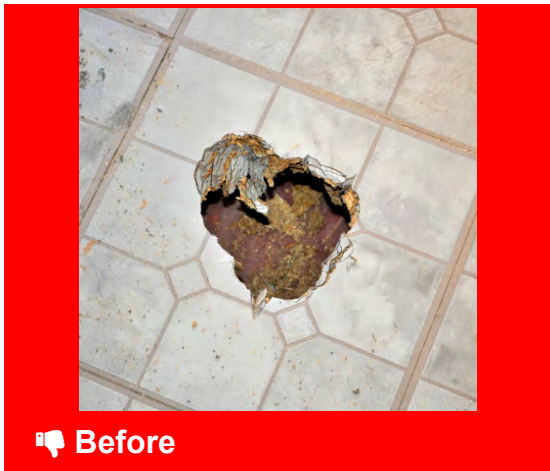

Holes in the floor should be repaired



Completed floor patches should be air sealed to prevent leakage from belly

Tools:

1. Saw
2. Tape measure
3. Caulk gun
4. Marker
5. Utility knife
6. Drill

Materials:

1. Plywood or other suitable subflooring material
2. Fasteners
3. Caulk
4. Sealant

3.1701.1h - Floor repair



1 When possible, measure patch to reach surrounding joist. If not, blocking will be required.



2 Mark damaged area to be removed to create most efficient patch

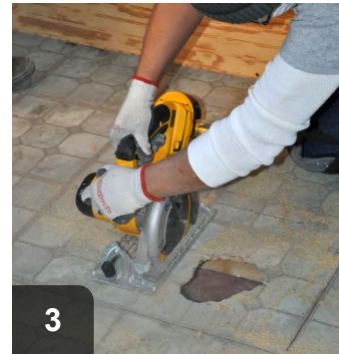

3 Cut out damaged area of floor, with minimal damage to surrounding floor and joists



4 Once damaged area has been removed, measure for new patch and cut replacement subflooring to size



5 Clean debris from surrounding area and mounting surfaces



6 Apply sealant to mounting surfaces



7 Securely fasten new subfloor in place, attaching to joist or blocking as necessary

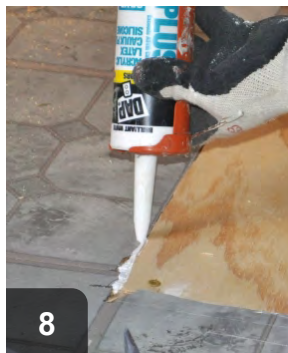

8 Seal gaps around patched in subfloor to create air seal between conditioned living space and crawl space

3.1701.1i

Desired Outcome:

The exterior of the seam is weathertight and connection between house and addition is properly sealed to minimize air leakage and moisture movement between unconditioned and conditioned space

Specification(s):

Materials will be used or installed in accordance with product manufacturer specifications

Objective(s):

Select materials to ensure durable and permanent repair



Use materials with sufficient strength to span openings and support repair materials without bending or sagging

Tools:

1. Caulking gun
2. Nail gun
3. Screw gun

Materials:

1. Nominal 2X framing lumber
2. 7/16" OSB or 1/2" CDX plywood
3. Nails or screws
4. Construction adhesive

3.1701.1j

Desired Outcome:

The exterior of the seam is weathertight and connection between house and addition is properly sealed to minimize air leakage and moisture movement between unconditioned and conditioned space

Specification(s):

Ceiling repair material must meet or exceed strength of existing ceiling material

Ceiling repair must span from truss to truss or add blocking as needed for support

The backing or infill will not bend, sag, or move once installed

All accessible damaged vapor barriers will be repaired

Penetrations through the air barrier must be repaired

Objective(s):

Ensure ceiling is structurally sound

Minimize air leakage

Ensure closure is permanent and supports expected wind and mechanical pressure loads

Ensure sealant does not fall out



Replace any missing insulation and repair holes in vapor barrier



Drywall patch before final sand and prime

Tools:

1. 6-inch and 12-inch drywall taping knives
2. Sanding block or sanding sponge
3. Utility knife
4. Keyhole saw
5. Screw gun

Materials:

1. Drywall or paneling
2. Fiberglass joint tape
3. Joint compound
4. Drywall screws or nails
5. Support material if needed (typically 1X4, 1X6, or 2X4 dimensional lumber)

For small holes, enlarge to a rectangular shape and install 1 X 4 blocks above two edges of the hole. For larger holes, enlarge opening to centers of nearest trusses and fasten the patch to the framing. For small holes, enlarge to a rectangular shape and install 1 X 4 blocks above two edges of the hole. For larger holes, enlarge opening to centers of nearest trusses and fasten the patch to the framing.

3.1701.1j - Ceiling hole repair

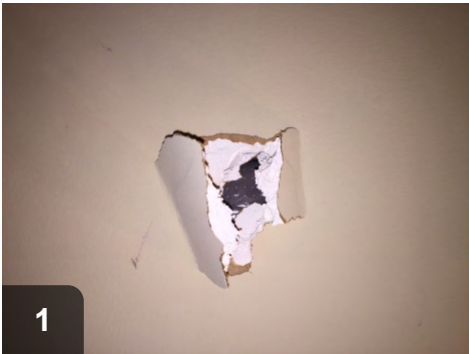

1
Replace any missing insulation and repair holes in vapor barrier



2
Prepare the hole by cutting the edges clean and square.



3
Cut drywall and fasten in place



4
Add joint tape and coat of joint compound

3.1701.1k

Desired Outcome:

The exterior of the seam is weathertight and connection between house and addition is properly sealed to minimize air leakage and moisture movement between unconditioned and conditioned space

Specification(s):

Only noncombustible materials will be used in contact with chimneys, vents, and flues

Objective(s):

Prevent a fire hazard



Gaps around floor penetrations allow air and moisture movement



Use non-combustible materials, like 26-gauge steel and high-temp caulk

Tools:

1. Caulk gun
2. Metal snips
3. Drill/screwdriver

Materials:

1. High-temperature caulk
2. Non-combustible material such as aluminum or galvanized steel flashing or cement board
3. Appropriate fasteners

3.1701.1k - High temperature application



1 Prepare work area by removing any insulation and debris



2 Use high-temperature caulking (600F min)



3 Apply first ring of caulking to match shape of opening



4 Apply second ring of caulking to size and shape of rigid material

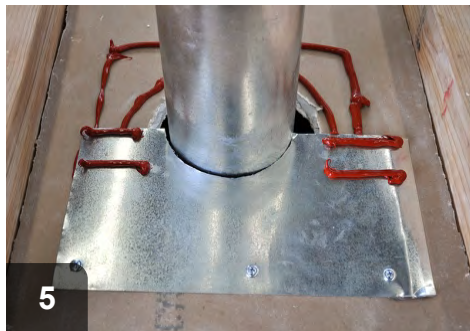

5 Fasten rigid material and apply additional caulking



6 Fasten rigid material to cover penetration and seal against flue with caulk

4.1002.1b

Desired Outcome:

Roof covering removed and replaced to expose roof deck for installation of above roof deck insulation

Specification(s):

New roof covering will be installed in accordance with manufacturer specifications and local building code requirements after installation of above roof deck insulation

Objective(s):

Install roof covering correctly

Meet local code requirements

4.1002.2a

Desired Outcome:

Properly installed roof deck insulation

Specification(s):

Holes, gaps, and penetrations in existing roof deck will be sealed

Objective(s):

Prevent air leaks

4.1002.2b

Desired Outcome:

Properly installed roof deck insulation

Specification(s):

Insulation will be installed according to manufacturer specifications without gaps, voids, compressions, misalignments, or wind intrusions

Insulation will be installed to prescribed R-value

Objective(s):

Install insulation properly

4.1002.2c

Desired Outcome:

Properly installed roof deck insulation

Specification(s):

A dated receipt signed by the installer will be provided that includes:

- Insulation type
- Coverage area
- R-value
- Installed thickness and settled thickness (settled thickness required for loose-fill only)
- Number of bags installed in accordance with manufacturer specifications (for loose-fill only)

Objective(s):

Document job completion to contract specifications

Confirm amount of insulation installed

Comply with 16 CFR 460.17

4.1003.8a

Desired Outcome:

Consistent, uniform thermal boundary and air barrier between the conditioned space and unconditioned space

Specification(s):

All combustion appliance flues will be terminated to the outdoors and terminations will maintain proper clearance above snow loads

A distance no less than 2" will be maintained between any combustion appliance flue and combustible materials, unless zero clearance flue is in place

All ventilation systems will maintain a continuous connection and terminate to the outdoors

All broken mushroom vents will be replaced or removed and sealed

All plumbing stacks will be terminated to the outdoors

Non-IC rated light fixtures will be replaced with airtight IC-rated fixtures

All recessed lights will be labeled as having an air leakage rate no more than 2.0 CFM when tested in accordance with ASTM E 283 at a 75 pascals pressure differential

All obvious ceiling penetrations will be sealed

The space between combustion appliance flues and the ceiling will be sealed with fire-rated materials

All roof, attic, and ceiling assemblies will be structurally sound; loose ceiling panels will be secured

Temporary ceiling bracing will be recommended during the insulation installation process

Dishing and pooling issues that allow standing water will be addressed

All known roof water leaks will be repaired before insulation installation

Objective(s):

Ensure occupant and worker safety

Verify attic space is ready to insulate

Ensure structural integrity of the roof and ceiling assembly

Prevent intrusion of bulk moisture

Prevent damage during the insulation installation process



Roof leak, missing cap on vent



Properly connected and sealed roof vent

Tools:

1. Scaffolding and ladders
2. Screw gun
3. Long, flat prybar
4. 5-in-one paint scraper tool
5. Flashlights and headlamps
6. Digital camera

Materials:

1. Wooden blocks

Inspect and correct each of the specified items: flues terminated to outside, 2" clearance to combustibles from flues, ventilation ducts terminated outdoors, non-airtight, non-IC rated recessed lighting replaced with airtight, IC-rated recessed units, broken mushroom vents replaced or removed, plumbing vents terminated outdoors, ceiling penetrations sealed, structural defects in roof, attic, and ceiling assemblies corrected, ponds on roof remedied, and all roof leaks repaired.

4.1003.8a - Attic, ceiling, and roof verification

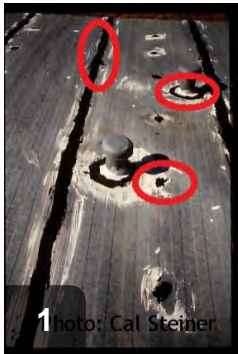

1 Photo: Cal Steiner

Inspect roof for evidence of water pooling, leaks, or damage. Verify proper vent terminations



2 Photo Credit: Cal Steiner

Inspect ceiling for weakness, leaks, clearance to combustibles, loose panels, and penetrations



3

Verify presence of rain caps on all vents



4

Inspect all patches and repairs, and correct deficiencies if necessary



5

Verify at least 2" clearance to combustibles, unless flue is designed for zero clearance. Repair if needed



6

Use temporary supports to avoid ceiling collapse during insulation install

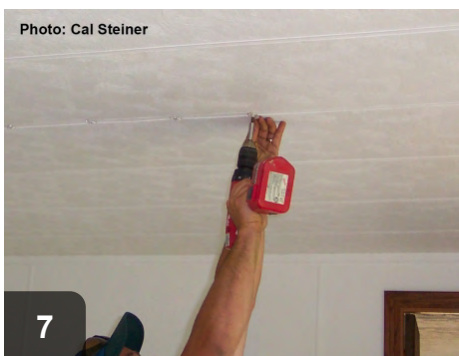

Photo: Cal Steiner

7

Add fasteners wherever needed to firmly attach ceiling to the trusses



Photo: Cal Steiner

8

Investigate all water stains and sources of moisture. Repair before insulating the attic



Photo: Cal Steiner

9

After opening the roof edge, verify proper clearance to combustibles and inspect vent connections

4.1003.8b

Desired Outcome:

Consistent, uniform thermal boundary and air barrier between the conditioned space and unconditioned space

Specification(s):

Fasteners will be removed from the J channel and the roof edge on the most easily accessible side of the house

Roof will be separated from the heel plate and siding roof will be lifted and propped to accommodate fill tube

Length of opening will be enough to allow ease of access and reattachment while minimizing potential damage from high winds

If subsheathing is present, access will be gained through subsheathing

Attic will be visually inspected for the location of existing insulation, obstructions, hazards, and construction type

Objective(s):

Create access to the full attic cavity

Protect roof from wind damage during installation

Ensure ease of roof reattachment

Determine insulation installation technique

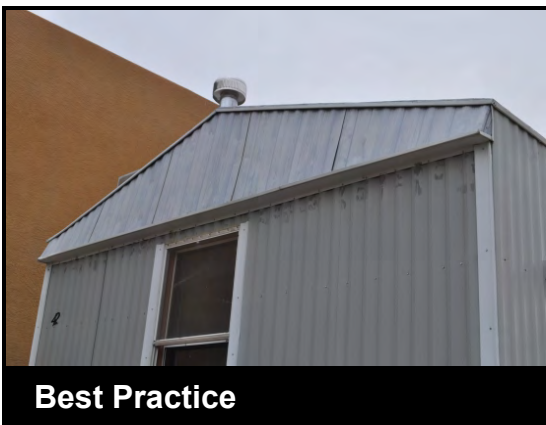

Pitched, bowed, and vaulted roofs are good candidates for insulation via roof side lift



Insulation can be installed without disturbing the interior environment

Tools:

1. Pry bar
2. Drill
3. Utility knife
4. Pliers

Materials:

1. Wood blocks

4.1003.8b - Attic access



Ensure a safe work environment by setting up scaffolding. Work in manageable sections



Remove fasteners from the J-channel



Cut through putty tape and pry J-channel away from roof seam



Work in manageable sections to minimize roof damage. One section of J-channel is a long enough area

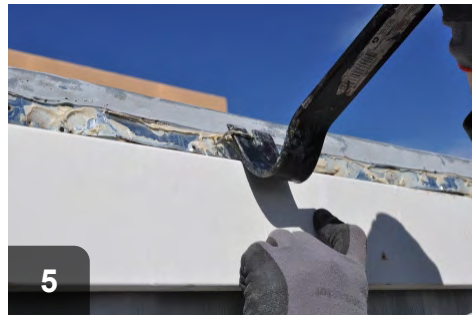

Remove staples as necessary to lift roof and inspect underneath



Place blocks to lift roof and enable inspection of roof cavity for obstructions and other concerns



Work in small sections to minimize flexing of roof and risk of wind damage



Once visual inspection has shown roof cavity to be viable, begin blowing insulation

4.1003.8c

Desired Outcome:

Consistent, uniform thermal boundary and air barrier between the conditioned space and unconditioned space

Specification(s):

Blowing machine pressure test will be performed with air on full, feed off, and gate closed

Hose outlet pressure will be set in accordance with manufacturer specifications

Objective(s):

Ensure machine is capable of delivering uniform insulation density and coverage



In Progress

Before loading insulation, check to ensure that machine is operating properly

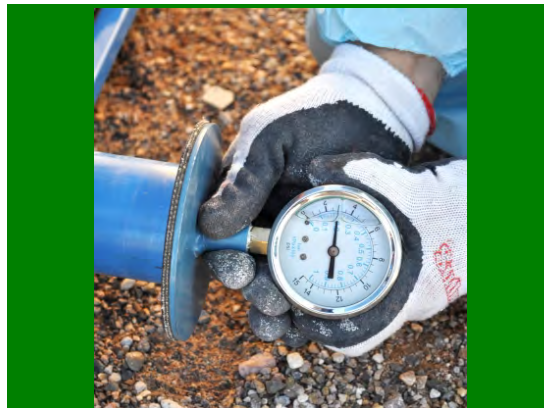

Best Practice

Test insulation blowing machine's pressure to ensure it is operating within manufacturer's parameters

Tools:

1. Hex wrench
2. Pressure gauge

4.1003.8c - Blowing machine set up



Set-up blowing machine on dry, level surface near electrical source and insulation site



Check electrical connections before operation



Make sure feed is off for testing and gate is closed

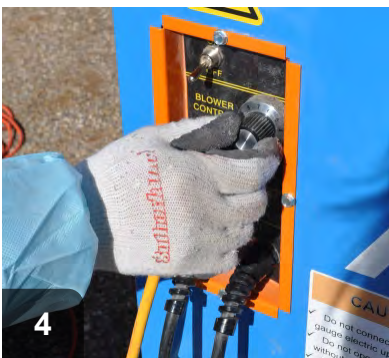

Adjust blower to full, or maximum



Using pressure gauge at feed outlet, verify that machine is working within manufacturer's specifications



If testing shows machine is operating properly, attach hose and tighten fitting to minimize slippage

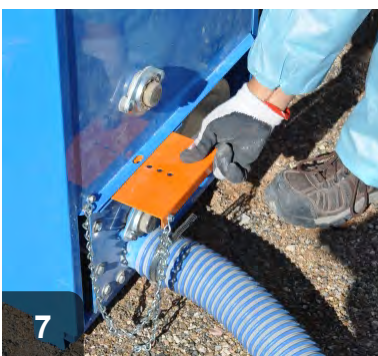

Open gate to allow for feed of insulation, turn on feed

4.1003.8d

Desired Outcome:

Consistent, uniform thermal boundary and air barrier between the conditioned space and unconditioned space

Specification(s):

Insulation will be installed to a density of 1.5 to 1.6 pounds per cubic foot

Using fill tube, 100% of each cavity will be filled to a consistent density

Fill tube will be inserted within 6" of the end of each attic cavity

Insulation will be installed into the void of the attic cavity:

- If existing insulation is roof-mounted, insulation will be blown below
- If existing insulation is ceiling-mounted, insulation will be blown above
- If existing insulation is mounted at both locations, insulation will be blown in between

Avoid overfilling of roof edges and above attic trusses

Flame spread and smoke-developed index for insulation will be a flame spread rating of 25 or less and a smoke development rating of 450 or less when tested in accordance with ASTM E84

Objective(s):

Fill entire attic cavity to the prescribed R-value to reduce air infiltration

Avoid clogging of the cavity and the fill tube

Prevent damage to the ceiling

Allow roof to be returned to original position

Fire safety will be maintained



4.1003.8d - Fiberglass blown insulation installation



If insulation is roof mounted, blow below it.



If insulation is ceiling mounted, blow above it.



If insulation is mounted at both the ceiling and the roof, blow between it.

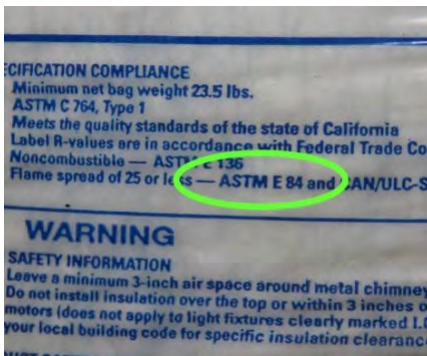

Insulation meets ASTM E 84.

4.1003.8e

Desired Outcome:

Consistent, uniform thermal boundary and air barrier between the conditioned space and unconditioned space

Specification(s):

If existing J channel is damaged, it will be replaced

Existing sealant will be removed from the roof edge and J channel

At a minimum, new sealant will be reinstalled at the original location

Roof and J channel will be fastened to the original location with new screws

All seams, edges, and penetrations will be sealed as necessary

Objective(s):

Prepare roof edge and J channel for reattachment

Reattach roof edge and J channel without leaks



Before

If salvageable, clean J-channel before reinstallation



After

Attach J-channel using old holes and new fasteners

Tools:

1. Drill
2. Utility knife
3. Snips

Materials:

1. Fasteners
2. J-channel
3. Putty tape

4.1003.8e - Roof reattachment



1
If J-channel is salvageable, clean thoroughly before applying putty tape



2
Apply putty tape to new or reused J-channel to seal roof seam



3
Using new fasteners, attach J-channel along roof seam and seal as necessary

4.1003.8f

Desired Outcome:

Consistent, uniform thermal boundary and air barrier between the conditioned space and unconditioned space

Specification(s):

Installation process will be considered complete when installer has verified that damage has not occurred to the roof or ceiling assemblies during the installation process

Objective(s):

Verify the integrity of the house has been maintained

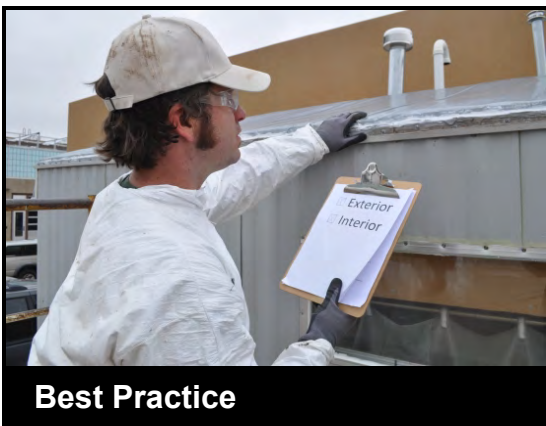

Best Practice

Exterior should be inspected to verify that roof has not been damaged



Best Practice

Interior ceiling should also be inspected to make sure that no damage was incurred

4.1003.8g

Desired Outcome:

Consistent, uniform thermal boundary and air barrier between the conditioned space and unconditioned space

Specification(s):

A dated receipt signed by the installer will be provided that includes:• Insulation type• Coverage area• R-value• Installed thickness and minimum settled thickness • Number of bags installed in accordance with manufacturer specifications

Objective(s):

Document job completion to contract specifications

Confirm amount of insulation installed

Ensure ability to match bags required for total area completed

Comply with 16 CFR 460.17

4.1003.9a

Desired Outcome:

Consistent, uniform thermal boundary and air barrier between the conditioned space and unconditioned space

Specification(s):

All combustion appliance flues will be terminated to the outdoors and terminations will maintain proper clearance above snow loads

A distance no less than 2" will be maintained between any combustion appliance flue and combustible materials, unless zero clearance flue is in place

All ventilation systems will maintain a continuous connection and terminate to the outdoors

All broken mushroom vents will be replaced or removed and sealed

All plumbing stacks will be terminated to the outdoors

Non-IC rated light fixtures will be replaced with airtight IC-rated fixtures

All recessed lights will be labeled as having an air leakage rate not more than 2.0 CFM when tested in accordance with ASTM E 283 at a 75 pascals pressure differential

All obvious ceiling penetrations will be sealed

The space between combustion appliance flues and the ceiling will be sealed with fire-rated materials

All roof, attic, and ceiling assemblies will be structurally sound:

- Loose ceiling panels will be secured
- Temporary ceiling bracing will be recommended during the insulation installation process

Dishing and pooling issues that allow standing water will be addressed

All known roof water leaks will be repaired before installing installation

Objective(s):

Ensure occupant and worker safety

Verify attic space is ready to insulate

Ensure structural integrity of the roof and ceiling assembly

Prevent intrusion of bulk moisture

Prevent damage while installing insulation



 Before

Roof leak, missing cap on vent



 After

Properly connected and sealed roof vent

Tools:

1. 2-1/2" hole saw
2. Power drill
3. Borescope
4. Inspection mirror
5. Flashlight

Materials:

1. Material requirements will vary based on conditions
2. Drywall or paneling
3. IC/Airtight recessed lights
4. Fire caulk
5. Vent terminations
6. Silicone caulk
7. Galvanized sheet metal and screws
8. Roof cement
9. Temporary ceiling bracing

Inspect and correct each of the specified items: flues terminated to outside, 2" clearance to combustibles from flues, ventilation ducts terminated outdoors, non-airtight, non-IC rated recessed lighting replaced with airtight, IC-rated recessed units, broken mushroom vents replaced or removed, plumbing vents terminated outdoors, ceiling penetrations sealed, structural defects in roof, attic, and ceiling assemblies corrected, ponds on roof remedied, and all roof leaks repaired.

4.1003.9a - Attic, ceiling, and roof verification

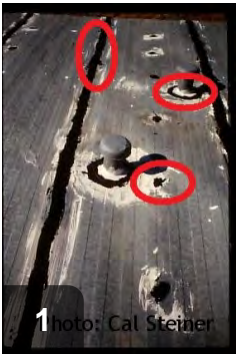

1 Photo: Cal Steiner
Inspect roof for evidence of water pooling, leaks, or damage. Verify proper vent terminations



2
Inspect all patches and repairs, and correct deficiencies if necessary



3
Verify presence of rain caps on all vents



4 Photo Credit: Cal Steiner
Inspect ceiling for weakness, leaks, clearance to combustibles, loose panels, and penetrations



5
Verify at least 2" clearance to combustibles, unless flue is designed for zero clearance. Repair if needed



6 Photo: Cal Steiner
Repair and refasten sagging or unsecured ceiling panels. Caulk and seal seams to prevent insulation spilling into house



7
Use temporary supports to avoid ceiling collapse during insulation install

4.1003.9b

Desired Outcome:

Consistent, uniform thermal boundary and air barrier between the conditioned space and unconditioned space

Specification(s):

Access to the attic cavity will be created using one of these methods:

- Drilling
- Cutting
- Continuous slicing along the center line (at the highest point of the roof)

Access location will be placed to allow for consistent and uniform coverage of installed insulation throughout the attic assembly

There will be, at a minimum, one opening between each roof truss

Openings will be large enough to accommodate the chosen fill tube

If subsheathing is present, access will be gained through subsheathing

Attic will be visually inspected for the location of existing insulation, wiring, flues, obstructions, hazards, and construction type

Objective(s):

Create access to the full attic cavity

Maintain the integrity of the roof truss

Protect roof from wind damage during installation

Determine technique for installing insulation

**In Progress**

Manufactured home attic access by slicing along ridgeline

Tools:

1. 7-1/4" circular saw
2. Electric drill
3. Carbide-tipped hole saw bits
4. Insulation blowing machine
5. 2" PVC pipe, 10 feet long
6. 4-1/2" or 7" angle grinder with flexible sanding wheels
7. Tape measure and chalk lines
8. Scaffolding

Materials:

1. Abrasive or carbide-toothed cutting wheels

If attic has both flat and vaulted ceilings, access may be gained through the gable ends for the flat ceilings.

Always use hand protection when working with metal edges and/or sharp tools.

4.1003.9b - Attic access



Determine and mark truss locations on roof, and choose method of access. Avoid drilling or sawing into trusses



Option 1: Drill a 4" hole in each truss cavity two to three feet down from the ridge



Option 2: Cut a hole into each truss cavity, big enough to inspect the opening and admit the fill tube



Pull cut edges of roof back to allow for inspection, repairs, and insulation installation



Option 3: Cut the roof open along the highest point from end to end. Make crosswise cuts at each end if needed



Regardless of access method, visually inspect attic for existing insulation, wiring, flues, obstructions, and hazards

4.1003.9c

Desired Outcome:

Consistent, uniform thermal boundary and air barrier between the conditioned space and unconditioned space

Specification(s):

Blowing machine pressure test will be performed with air on full, feed off, and gate closed

Hose outlet pressure will be set in accordance with manufacturer specifications

Objective(s):

Ensure machine is capable of delivering uniform insulation density and coverage



In Progress

Before loading insulation, check to ensure that machine is operating properly

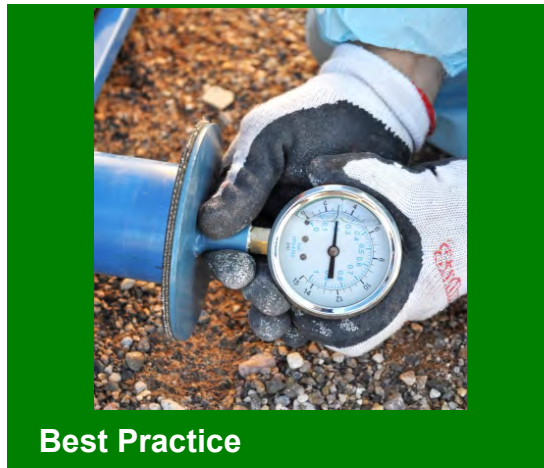

Best Practice

Test to verify that machine is operating within manufacturer's limits

Tools:

1. Pressure gauge
2. Generator

4.1003.9c - Blowing machine set up



Set-up blowing machine on dry, level surface near electrical source and insulation site

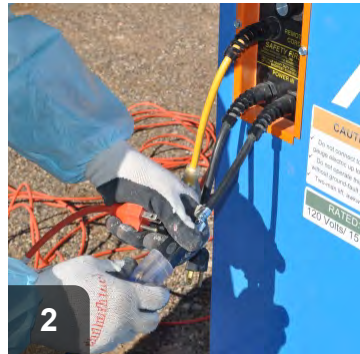

Check electrical connections before operation



Make sure feed is off for testing and gate is closed

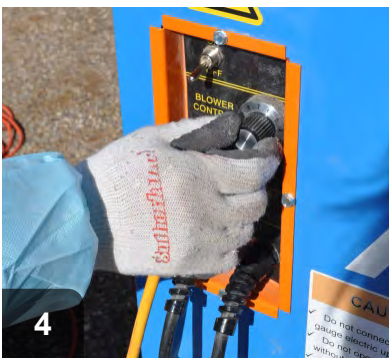

Adjust blower to full, or maximum



Using pressure gauge at feed outlet, verify that machine is working within manufacturer's specifications



If testing shows machine is operating properly, attach hose and tighten fitting to minimize slippage

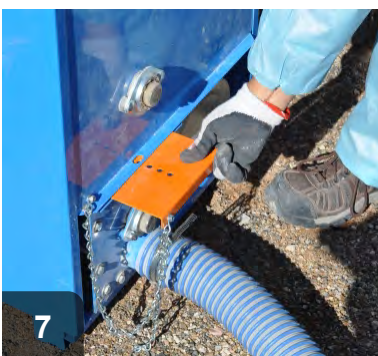

Open gate to allow for feed of insulation, turn on feed

4.1003.9d

Desired Outcome:

Consistent, uniform thermal boundary and air barrier between the conditioned space and unconditioned space

Specification(s):

Insulation will be installed to a density of 1.5 to 1.6 pounds per cubic foot

Using fill tube, 100% of each cavity will be filled to a consistent density

Fill tube will be inserted within 6" of the end of each attic cavity

Insulation will be installed into the void of the attic cavity:

- If existing insulation is roof-mounted, insulation will be blown below
- If existing insulation is ceiling-mounted, insulation will be blown above
- If existing insulation is mounted at both locations, insulation will be blown in between

Insulation will be filled no higher than the top of the truss

Flame spread and smoke-developed index for insulation will be a flame spread rating of 25 or less and a smoke development rating of 450 or less when tested in accordance with ASTM E84

Objective(s):

Fill entire attic cavity to the prescribed R-value to reduce air infiltration

Avoid clogging of the cavity and the fill tube

Prevent damage to the ceiling

Allow roof to be returned to original position

Fire safety will be maintained



In Progress

Always wear PPE appropriate to the work environment and job at hand.

4.1003.9d - Fiberglass blown insulation installation



If insulation is roof mounted, blow below it.



If insulation is ceiling mounted, blow above it.



If insulation is mounted at both the ceiling and the roof, blow between it.

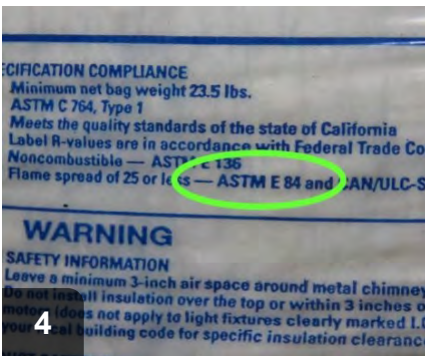

Insulation meets ASTM E 84.

4.1003.9e

Desired Outcome:

Consistent, uniform thermal boundary and air barrier between the conditioned space and unconditioned space

Specification(s):

If the roof is sliced:

- A solid metal ridge cap will be centered over the slice
- A flexible and durable sealant will be sandwiched between the roof and the ridge cap
- Screws will be installed to prevent wrinkles and create a permanent seal
- Screws will not go into any wood framing
- A durable and flexible final coating will be applied over the screws and edge of the ridge cap to create a continuous seal between the roof and the perimeter of the ridge cap

For holes that are drilled or cut, the initial patch will be applied using the following procedure:

- At least 6" of surface surrounding the opening will be cleaned before patch is installed
- Sealant will be continuous and applied in between the patch and the roof
- Sealant will be an all-weather adhesive that is flexible and durable

If a metal patch is used:

- Patch will overlap the opening by 2" on all sides
- Gauge will be equal to or greater than the roof material
- Fasteners will be installed to prevent wrinkles and create a permanent seal
- If a plug is used, it will be flanged and have a tight fit
- Screws will not go into any wood framing

A durable and flexible 45 mil adhesive patch will be applied in accordance to manufacturer specifications over the initial patch and will have at a minimum:

- Tear strength of 640g
- Elongation of 380%
- Application temperature no lower than 55°F and no greater than 110°F
- Services temperature no less than -25°F and no greater than 150°F
- Adhesive patch will overlap the initial patch by 2" on all sides
- A durable and flexible final coating will be applied over the adhesive patch to create a continuous seal between the roof and the perimeter of the patch
- All remaining seams, edges, and penetrations will be sealed as necessary

Objective(s):

Effectively patch and seal all openings

Create a durable patch that will prevent roof leaks



Rough cut hole that will need to be sealed.

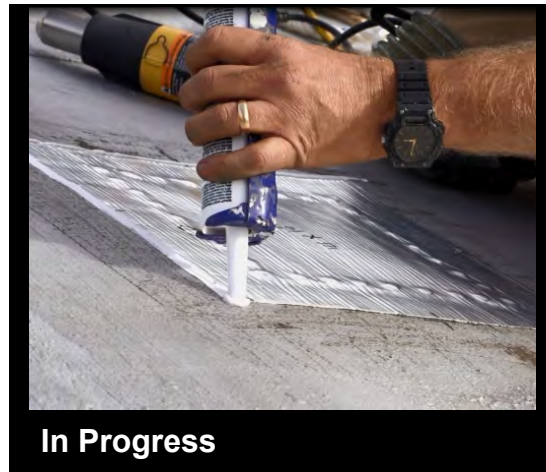

Placing sealant around the exposed edges of the roof patch ensures a watertight seal.

Tools:

1. Roller
2. Self adhering patch
3. sheet metal
4. 6" duct cap(to match 6" hole)
5. heat gun
6. drill

4.1003.9e - Patching and sealing openings



Insert 6" plug and seal around the perimeter of the opening.



Firmly push the plug into place, until it is flush with the roof surface.



Use a 10"x10" sheet metal patch to mark the center of the hole.



Apply sealant to the underside of the sheet metal patch.



Secure the metal patch to the roof being sure to place mechanical fasteners through the sealant.



Apply a 14"x14" self adhering roof patch on top of the sheet metal patch.



Use a heat gun to make the adhesive pliable to get the best possible seal.

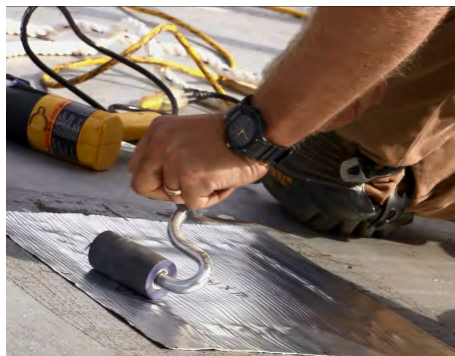

Forcefully roll the patch into place, starting from the center and working toward the edge.

4.1003.9f

Desired Outcome:

Consistent, uniform thermal boundary and air barrier between the conditioned space and unconditioned space

Specification(s):

Installation process will be considered complete when installer has verified that damage has not occurred to the roof or ceiling assemblies during the installation process

Objective(s):

Verify the integrity of the house has been maintained



In Progress

Verify that no damage has been done by the workers. When in doubt, verify with photo documentation.



After

Document and repair any damage the workers caused.

Tools:

1. IR camera

4.1003.9g

Desired Outcome:

Consistent, uniform thermal boundary and air barrier between the conditioned space and unconditioned space

Specification(s):

A dated receipt signed by the installer will be provided that includes:

- Insulation type
- Coverage area
- R-value
- Installed thickness and minimum settled thickness
- Number of bags installed in accordance with manufacturer specifications

Objective(s):

Document job completion to contract specifications

Confirm amount of insulation installed

Ensure ability to match bags required for total area complete

Comply with 16 CFR 460.17

4.1003.10a

Desired Outcome:

Consistent, uniform thermal boundary and air barrier between the conditioned space and unconditioned space

Specification(s):

All combustion appliance flues will be terminated to the exterior of the house and terminations will maintain proper clearance above snow loads

A distance no less than 2" will be maintained between any combustion appliance flue and combustible materials, unless zero clearance flue is in place

All ventilation systems will maintain a continuous connection and terminate to the outdoors

All broken mushroom vents will be replaced or removed and sealed

All plumbing stacks will be terminated to the outdoors

Non-IC rated light fixtures will be replaced with airtight IC-rated fixtures, if feasible and only when installed measures will compromise the fire rating of the fixture

All recessed lights will be labeled as having an air leakage rate no more than 2.0 CFM when tested in accordance with ASTM E 283 at a 75 pascals pressure differential

All obvious ceiling penetrations will be sealed

The space between combustion appliance flues and the ceiling will be sealed with fire-rated materials

All roof, attic, and ceiling assemblies will be structurally sound:

- Loose ceiling panels will be secured
- Temporary ceiling bracing will be recommended while installing installation

Dishing and pooling issues that allow standing water will be addressed

All known roof water leaks will be repaired before installing installation

Objective(s):

Ensure occupant and worker safety

Verify attic space is ready to insulate

Ensure structural integrity of the roof and ceiling assembly

Prevent intrusion of bulk moisture

Prevent damage while installing insulation



Best Practice

90+ flue terminates above the snow line and penetrations have been sealed.



Best Practice

Flue penetrations have been sealed correctly from the interior.

4.1003.10a - Attic, ceiling, and roof verification



Plumbing stacks must be terminated to the outdoors.



Dishing and pooling issues must be addressed.



Mushroom vents must be replaced, or removed and sealed.



Proper clearance to combustibles will be maintained through the roof assembly.



Inspect ceiling for weakness, leaks, clearance to combustibles, loose panels, and penetrations.

4.1003.10b

Desired Outcome:

Consistent, uniform thermal boundary and air barrier between the conditioned space and unconditioned space

Specification(s):

Special precautions will be taken to limit fiberglass and construction dust exposure to the occupant and occupant belongings

Objective(s):

Protect occupant health and safety

Protect occupant belongings

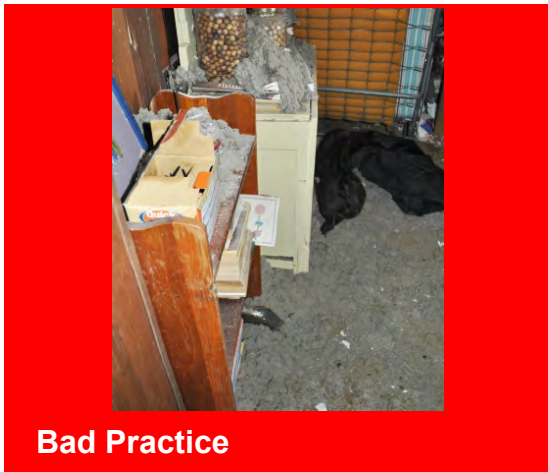

Bad Practice

Improperly prepared workspace with cellulose all over client belongings and bedroom



Best Practice

Worker has removed or covered occupant belongings. Be sure to ask permission before removing any client belongings

Tools:

1. Utility knife

Materials:

1. Plastic sheeting
2. Removable, low-residue tape

4.1003.10c

Desired Outcome:

Consistent, uniform thermal boundary and air barrier between the conditioned space and unconditioned space

Specification(s):

Equidistant holes will be drilled in a straight row parallel to the longitudinal exterior wall of the ceiling

If a longitudinal ceiling trim piece exists, trim piece will be removed and holes will be drilled behind the trim

Hole location and size will be placed to provide access to allow for consistent and uniform coverage of installed insulation throughout the attic assembly

There will be, at a minimum, one hole between each roof truss

Holes will be large enough to accommodate the chosen fill tube without damaging the ceiling material during installation

If a vapor barrier or ceiling-mounted insulation is present, access will be gained through them

Attic will be visually inspected for the location of existing insulation, obstructions, hazards, and construction type

Objective(s):

Create access to the full attic cavity

Determine insulation installation technique

Prevent damage to ceiling

Create a professionally finished ceiling



In Progress

Holes are drilled in such a fashion that they allow uniform coverage of attic insulation.

Tools:

1. holesaw bit
2. drill
3. borescope
4. camera



In Progress

Hole is the proper size in relation to the fill tube.

Materials:

1. protective plastic

4.1003.10d

Desired Outcome:

Consistent, uniform thermal boundary and air barrier between the conditioned space and unconditioned space

Specification(s):

Blowing machine pressure test will be performed with air on full, feed off, and gate closed

Hose outlet pressure will be set in accordance with manufacturer specifications

Objective(s):

Ensure machine is capable of delivering uniform insulation density and coverage



In Progress

Before loading insulation, check to ensure that machine is operating properly

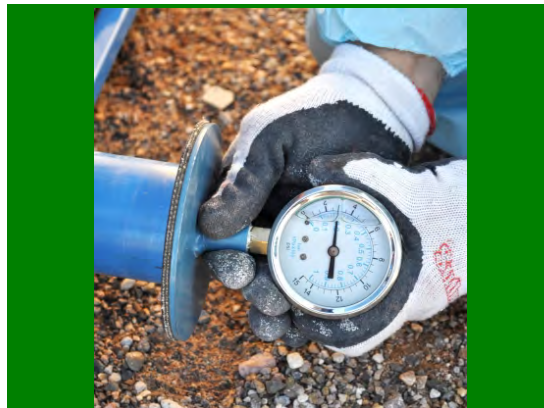

Best Practice

Test insulation blowing machine's pressure to ensure it is operating within manufacturer's parameters

Tools:

1. Pressure gauge
2. Hex wrench

4.1003.10d - Blowing machine set up



Set-up blowing machine on dry, level surface near electrical source and insulation site

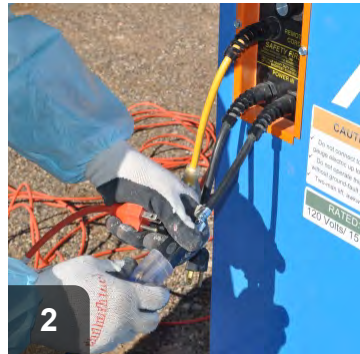

Check electrical connections before operation



Make sure feed is off for testing and gate is closed

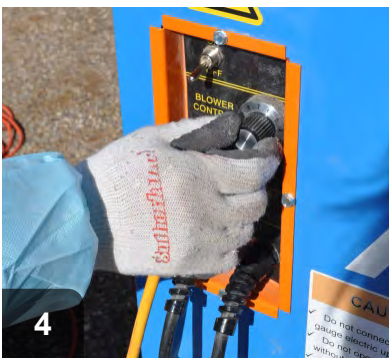

Adjust blower to full, or maximum



Using pressure gauge at feed outlet, verify that machine is working within manufacturer's specifications



If testing shows machine is operating properly, attach hose and tighten fitting to minimize slippage

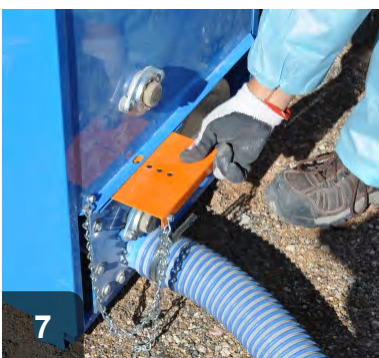

Open gate to allow for feed of insulation, turn on feed

4.1003.10e

Desired Outcome:

Consistent, uniform thermal boundary and air barrier between the conditioned space and unconditioned space

Specification(s):

Insulation will be installed to a density of 1.5 to 1.6 pounds per cubic foot

Using fill tube, 100% of each cavity will be filled to a consistent density

Fill tube will be inserted within 6" of the end of each attic cavity

Insulation will be installed into the void of the attic cavity:

- If existing insulation is roof-mounted, insulation will be blown below
- If existing insulation is ceiling-mounted, insulation will be blown above
- If existing insulation is mounted at both locations, insulation will be blown in between

Flame spread and smoke-developed index for insulation will be a flame spread rating of 25 or less and a smoke development rating of 450 or less when tested in accordance with ASTM E84

Objective(s):

Fill entire attic cavity to the prescribed R-value to reduce air infiltration

Avoid clogging of the cavity and the fill tube

Prevent damage to the ceiling

Fire safety will be maintained



Attic insulation should be consistently installed in each cavity to the edge.

4.1003.10e - Fiberglass blown insulation installation



1
If insulation is roof mounted, blow below it.



2
If insulation is ceiling mounted, blow above it.



3
If insulation is mounted at both the ceiling and the roof, blow between it.

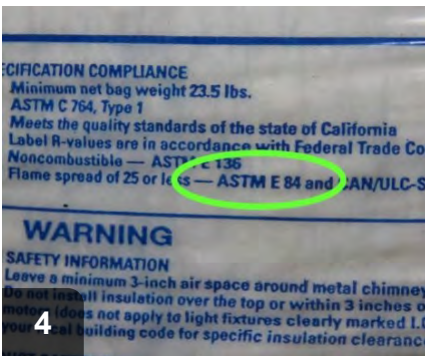

4
Insulation meets ASTM E 84.

4.1003.10f

Desired Outcome:

Consistent, uniform thermal boundary and air barrier between the conditioned space and unconditioned space

Specification(s):

Holes will be plugged or covered and sealed to be aesthetically pleasing

If existing trim was removed, it will be reinstalled

Objective(s):

Create an airtight seal

Create a visually acceptable ceiling finish



In Progress

Holes should be effectively sealed, as well as aesthetically pleasing.

Tools:

1. color matched plug

Materials:

1. color matched plug

4.1003.10g

Desired Outcome:

Consistent, uniform thermal boundary and air barrier between the conditioned space and unconditioned space

Specification(s):

Installation process will be considered complete when installer has verified that damage has not occurred to the roof or ceiling assemblies during the installation process

Objective(s):

Verify the integrity of the house has been maintained



In Progress

Verify that no damage has been done by the workers. When in doubt, verify with photo documentation.

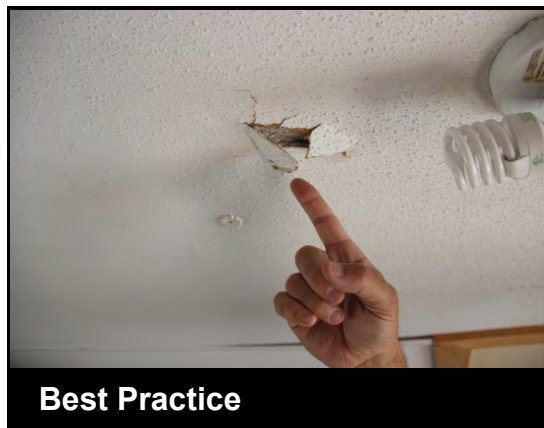

Best Practice

Document and repair any damage the workers caused.

4.1003.10h

Desired Outcome:

Consistent, uniform thermal boundary and air barrier between the conditioned space and unconditioned space

Specification(s):

A dated receipt signed by the installer will be provided that includes:

- Insulation type
- Coverage area
- R-value
- Installed thickness and minimum settled thickness
- Number of bags installed in accordance with manufacturer specifications

Objective(s):

Document job completion to contract specifications

Confirm amount of insulation installed

Ensure ability to match bags required for total area completed

Comply with 16 CFR 460.17

4.1003.11a

Desired Outcome:

Consistent, uniform thermal boundary and air barrier between the conditioned space and unconditioned space

Specification(s):

If occupant will allow access from interior, installation through the ceiling is preferred

Attic space created by the roof-over will be accessed in accordance with the Single-Family Attic Access SWS

If the roof-over does not allow physical access to the roof-over attic, access to the original attic will be gained through roof venting

If existing insulation height in the attic is less than the height of the heel plate (original attic), access will be made through the original roof and the original attic cavities will be filled before blowing insulation over the original roof

At a minimum, the access holes to the original attic cavities will be sealed to prevent air leakage

If existing insulation height is equal to or greater than the height of the heel plate (original attic), the insulation will be installed in the end cavities before blowing on top of the original roof

Access to the end cavities will be gained and insulation will be installed

At a minimum, the access holes to the original attic cavities will be sealed to prevent air leakage

Insulation will not be installed on top of the original roof until the end cavities are insulated and air sealed in original attic

If insulation is installed on top of the original roof, it will be installed in accordance with the Single-Family SWS Loose Fill Blown Fiberglass Insulation Installation

Objective(s):

Gain access to the combined attic spaces

Address thermal bridging

Correctly insulate the combined attic spaces

4.1003.11b

Desired Outcome:

Consistent, uniform thermal boundary and air barrier between the conditioned space and unconditioned space

Specification(s):

A dated receipt signed by the installer will be provided that includes:

- Insulation type
- Coverage area
- R-value
- Installed thickness and minimum settled thickness
- Number of bags installed in accordance with manufacturer specifications

Objective(s):

Document job completion to contract specifications

Confirm amount of insulation installed

Ensure ability to match bags required for total area completed

Comply with 16 CFR 460.17

4.1088.6a

Desired Outcome:

Consistent, uniform thermal boundary and air barrier between the conditioned space and unconditioned space

Specification(s):

A visual inspection of the highest point of the transition wall will be completed

Access points will be determined from the gable end, roof, ceiling, or interior paneling

Objective(s):

Verify the height and the accessibility of the attic

4.1088.6b

Desired Outcome:

Consistent, uniform thermal boundary and air barrier between the conditioned space and unconditioned space

Specification(s):

Attic will be accessed through the location that allows the most efficient and effective insulation coverage

Objective(s):

Gain access to the flat and cathedral ceiling transition wall

4.1088.6c

Desired Outcome:

Consistent, uniform thermal boundary and air barrier between the conditioned space and unconditioned space

Specification(s):

Blowing machine pressure test will be performed with air on full, feed off, and gate closed

Insulation will be blown against the transition wall until the wall is covered

Objective(s):

Ensure machine is capable of delivering uniform insulation density and coverage to meet manufacturer specifications for loose blown insulation

Create a thermal barrier at the transition wall



👍 Before

Before loading insulation, check to ensure that machine is operating properly.

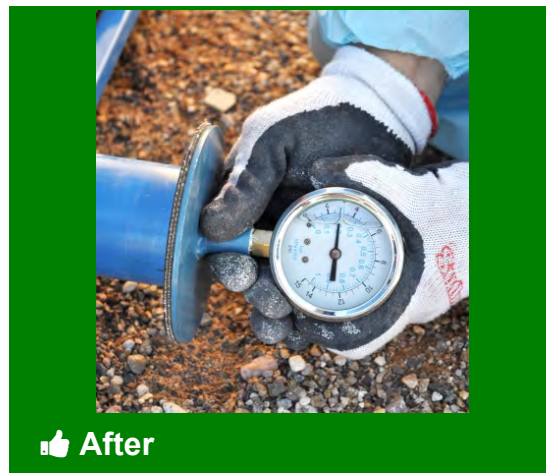

👍 After

Test insulation blowing machine's pressure to ensure it is operating within manufacturer's parameters.

4.1088.6c - Blowing



Set-up blowing machine on dry, level surface near electrical source and insulation site.



Check electrical connections before operation.



Make sure feed is off for testing and gate is closed.

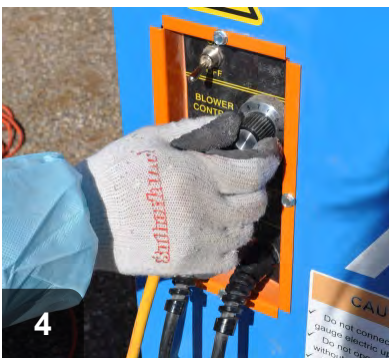

Adjust blower to full, or maximum.



Using pressure gauge at feed outlet, verify that machine is working within manufacturer's specifications.



If testing shows machine is operating properly, attach hose and tighten fitting to minimize slippage.

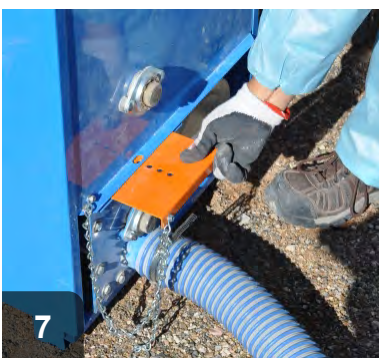

Open gate to allow for feed of insulation, turn on feed.

4.1088.6d

Desired Outcome:

Consistent, uniform thermal boundary and air barrier between the conditioned space and unconditioned space

Specification(s):

Insulation will be installed to prescribed R-value in accordance with manufacturer specifications

Spray polyurethane foam (SPF) will be applied to desired thickness, using pass thickness maximum as indicated by manufacturer

Objective(s):

Insulate and seal transition wall

4.1088.6e

Desired Outcome:

Consistent, uniform thermal boundary and air barrier between the conditioned space and unconditioned space

Specification(s):

Batt insulation will be installed in accordance with manufacturer specifications without gaps, voids, compressions, misalignments, or wind intrusions

Insulation will be installed to the prescribed R-value

Vapor barrier will be installed based on regional considerations

Objective(s):

Insulate to prescribed R-value

4.1088.6f

Desired Outcome:

Consistent, uniform thermal boundary and air barrier between the conditioned space and unconditioned space

Specification(s):

Created access points will be covered and sealed in an aesthetically pleasing manner

Existing access points (e.g., gable vent) will be returned to the original condition

If existing trim was removed, it will be reinstalled

Objective(s):

Create an airtight seal

Create an aesthetically pleasing finish

4.1088.6g

Desired Outcome:

Consistent, uniform thermal boundary and air barrier between the conditioned space and unconditioned space

Specification(s):

Installation process will be considered complete when installer has verified that damage has not occurred to the roof or ceiling assemblies during the installation process

Objective(s):

Verify the integrity of the house has been maintained



In Progress

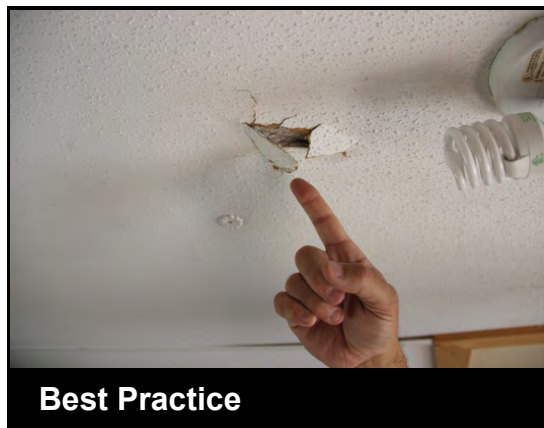

Best Practice

Verify that no damage has been done by the workers. When in doubt, verify with photo documentation.

4.1088.6h

Desired Outcome:

Consistent, uniform thermal boundary and air barrier between the conditioned space and unconditioned space

Specification(s):

A dated receipt signed by the installer will be provided that includes:

- Insulation type
- Coverage area
- R-value
- Installed thickness and settled thickness (settled thickness required for loose-fill only) •
Number of bags installed in accordance with manufacturer specifications (for loose-fill only)

Objective(s):

Document job completion to contract specifications Confirm amount of insulation installed Comply with 16 CFR 460.17

4.1101.5a

Desired Outcome:

Walls properly prepared to receive dense pack insulation

Specification(s):

Lead safety procedures will be followed

Cavities will be free of hazards, intact, and able to support dense pack pressures

Drilling hazards (e.g., wiring, venting, fuel piping) will be located

Blocking will be installed around:

- All openings to inside of the crawl space and basement for fibrous material
- High temperature fire-rated materials
- Wiring and electrical hazards
- Heat sources

Access to exterior wall cavities will be gained, sheathing will be drilled as needed and probed to locate each cavity, wall studs, and blockers

When accessing wall cavities, the interior will be masked to control dust during drilling

Electricity supply will be confirmed and will support blowing machine power demand

Blowing machine pressure test will be performed with air on highest level, feed off, and gate closed

Hose outlet pressure will be at least 80 IWC or 2.9 psi for cellulose insulation; for other types of dense pack insulation, check manufacturer specification for blowing machine set up

Objective(s):

Prevent damage to the house

Provide a clean work space

Provide thorough access to allow 100% coverage

Ensure proper equipment and process results in consistent density

Prevent settling and retard air flow through cavities

Protect worker and occupant health

4.1101.5b

Desired Outcome:

Walls properly prepared to receive dense pack insulation

Specification(s):

Using fill tube, 100% of each cavity will be filled to a consistent density:

- Blown fiberglass, mineral fiber, rock and slag wool, or spray foam used in an enclosed cavity will be installed at or above the manufacturer recommended density to limit air flow that corresponds to an air permeance value of 3.5 cubic feet per minute per square foot at 50 pascals
- Cellulose material will be installed to a minimum density of 3.5 pounds per cubic foot when the wall sheathing and interior cladding will endure this level of pressure
- Loose fiberglass material will be installed and will be specifically approved for air flow resistance to a minimum density in accordance with manufacturer specifications
- The number of bags installed will be confirmed and will match the number to achieve 1.5-1.6 pounds per cubic foot
- Insulation will be verified to prevent visible air movement using chemical smoke at 50 pascals of pressure difference

Objective(s):

Eliminate voids and settling

Minimize framing cavity air flows

4.1104.1a

Desired Outcome:

Consistent thermal boundary and air barrier between the conditioned space and unconditioned space

Specification(s):

If skirting overlaps siding, skirting will be detached to allow access to the wall cavity

Fasteners will be removed from the bottom of the siding, working upward until the siding can be pulled away from the framing approximately 6" without damaging the siding

Temporary fasteners will be installed near the bottom of the siding panels at the seams to prevent separation

If a subsheathing is present under the siding, access through the subsheathing will be required

Objective(s):

Gain access to the wall cavity without damaging or separating the siding



In Progress

Remove fasteners from along bottom and side seams to access wall cavity



After

Remove enough fasteners to create at least a 6in gap without damaging siding

Tools:

1. Drill

4.1104.1a - Access wall cavities



If skirting overlaps siding, remove skirting



Temporarily fasten siding panels at joint to hold seam together



Seam should remain together with temporary fastener

4.1104.1b

Desired Outcome:

Consistent thermal boundary and air barrier between the conditioned space and unconditioned space

Specification(s):

Wall cavities will be inspected for moisture damage, pest locations, and integrity of the wiring, and holes to the interior

Siding will be repaired as necessary

Location of belt rails, obstructions, and existing insulation will be identified

All interior surfaces of exterior walls will be inspected for loose paneling joints, occupant wall hangings, location of switches and outlets, and other wall obstructions

Objects will be removed from the interior surfaces of the walls being insulated

Interior paneling will be repaired as necessary

Objective(s):

Prepare wall cavity for insulation

Prevent water leaks from occurring

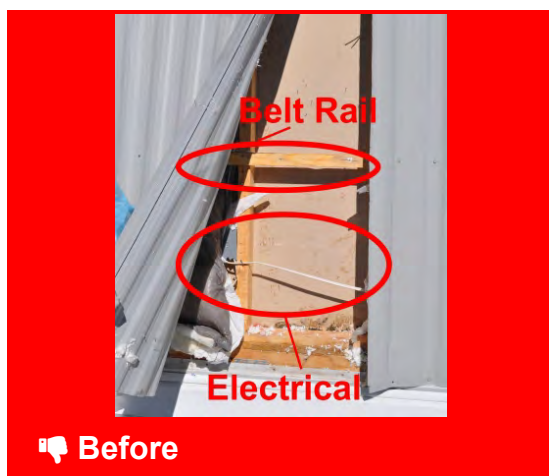

Take note of obstacles in the wall cavity, such as belt rails and electrical wiring

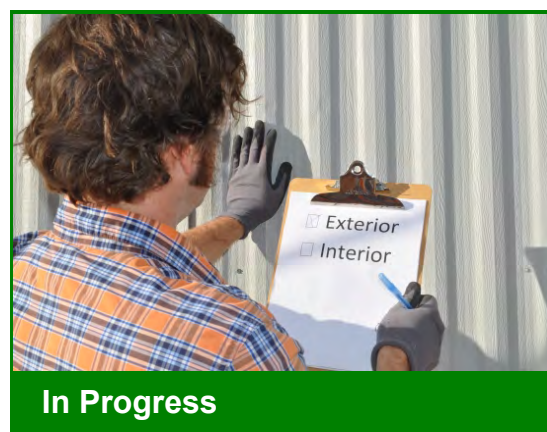

Assess that holes in both exterior siding and interior walls have been patched before beginning installation

Tools:

1. Drill
2. Utility knife
3. Taping knife
4. Caulk gun

Materials:

1. Spackle
2. Metal siding patch
3. Caulk
4. Fasteners

4.1104.1b - Exterior wall cavity inspection



Obstacles should be noted and planned for--insulation should be tucked behind belt rails

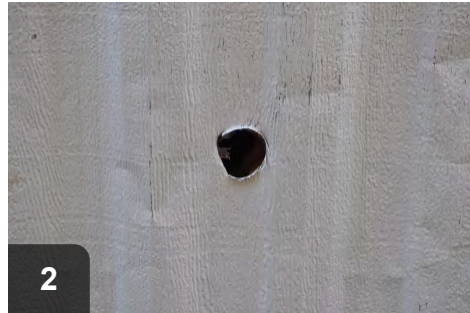

2 Holes in exterior siding should be patched



3 Apply sealant to back of patch to maintain air barrier



4 Ensure that patch is securely fastened and water-tight

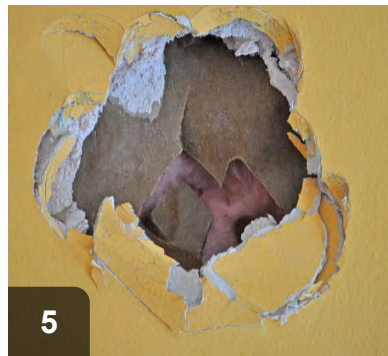

5 Holes and penetrations in the interior wall should be patched as well



6 Verify that patches to both interior and exterior have been completed before beginning installation

4.1104.1c

Desired Outcome:

Consistent thermal boundary and air barrier between the conditioned space and unconditioned space

Specification(s):

A sheet of polycarbonate, such as Lexan, will be cut to the following specifications to create a stuffer tool:

- Approximately 1' x 8' x 1/4" with a 5 degree bend 7' 1/2" from the bottom
- All corners of the Lexan (polycarbonate) will be rounded and all edges will be sanded

Other clear sheet plastics will not be used due to a tendency to shatter under stress

Objective(s):

Create a tool to install a fiberglass batt into the cavity

Ensure worker safety

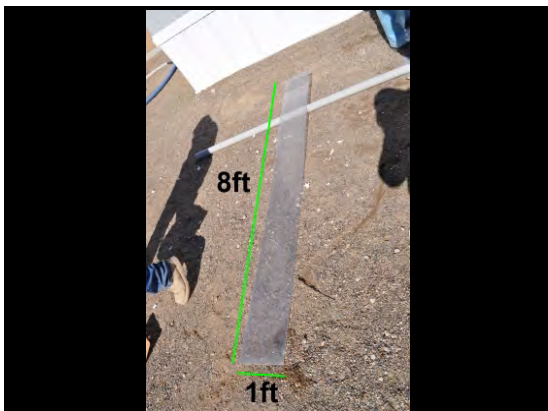

Best Practice

Insulation stuffing tool should be made of 1/4" polycarbonate, cut to 1' wide and 8' long

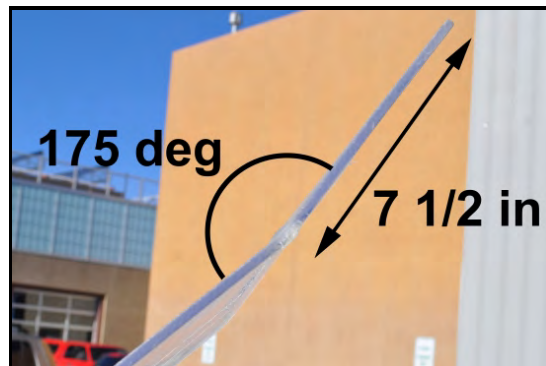

Best Practice

At one end, a bend of 5 degrees (175 degree supplement) should be made 7 1/2" from narrow edge

Tools:

1. Tape measure
2. Table saw with fine-toothed blade
3. Sander
4. Heat gun
5. Clamp
6. Protractor
7. Heat-resistant gloves

Materials:

1. Polycarbonate, like Lexan
2. Sandpaper

Most crews should have this tool in their supply. If one needs to be fabricated, find someone who has worked with polycarbonate before and ensure correct tool usage as well as proper PPE during fabrication.

4.1104.1d

Desired Outcome:

Consistent thermal boundary and air barrier between the conditioned space and unconditioned space

Specification(s):

Thickness of the batt will fill the void without deforming siding or damaging structure

Fiberglass batts will fill the cavity (e.g., batt may be cut approximately 1" longer to ensure proper fill and allow for lap at the top)

Flexible membrane will have an appropriate perm rating for the region

Flexible membrane will be cut 2" wider than the cavity and approximately 1' longer than the batt

Stuffer tool, membrane, and fiberglass batt will be aligned for installation

Stuffer tool will be used to install the fiberglass batt and membrane at the same time

Excess fiberglass batt and membrane vapor retarder extending below the cavity will be rolled and tucked into the cavity

A poly-encased fiberglass batt may be used in place of the fiberglass batt and membrane assembly

The membrane will be installed in contact with the side of the wall that is compatible with the local climate zone

Objective(s):

Maintain integrity of the batt

Aid in the installation process



 Before

Uninsulated and underinsulated wall cavities can be filled from the exterior with fiberglass batts

Tools:

1. Tape measure
2. Utility knife



 After

Fiberglass batt should fill entire cavity without creating bulging in exterior paneling

Materials:

1. Fiberglass batts, may be wrapped
2. Vapor barrier appropriate for region

4.1104.1d - Fiberglass batt installation

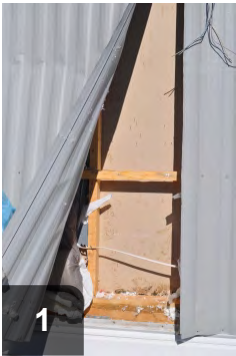

1
Uninsulated wall cavity can be accessed from exterior of mobile home through paneling

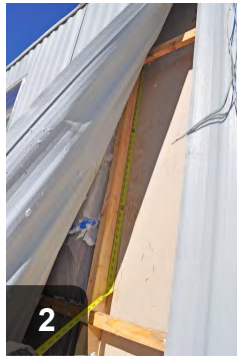

2
Measure length of cavity



3
Measure depth of cavity



4
Select appropriate batt thickness and R-value. Wrapped batts provide a built in vapor barrier



5
Measure batt to length of cavity with extra for overlap from stuffing tool



6
Lap cut batt over bent end of stuffing tool

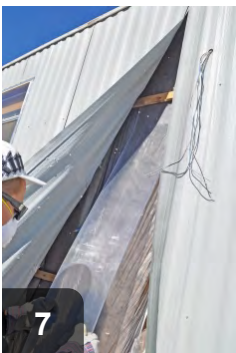

7
Beginning with lapped end, tuck batt under top belt rail and stuff batt up to top of cavity. Remove stuffing tool



8
Tuck bottom of batt behind bottom belt rail. If longer than cavity, cut to within 1" longer, roll and tuck into cavity

4.1104.1e

Desired Outcome:

Consistent thermal boundary and air barrier between the conditioned space and unconditioned space

Specification(s):

Subsheathing will be patched or repaired as necessary

Objective(s):

Ensure the integrity of the drainage plane

4.1104.1f

Desired Outcome:

Consistent thermal boundary and air barrier between the conditioned space and unconditioned space

Specification(s):

If skirting was removed, skirting will be reinstalled to shed water to the outside of the skirting

Siding will be reattached with new fasteners

Siding will be reattached without bulges or wrinkles

Objective(s):

Ensure the integrity of the drainage plane

Return siding to existing conditions without damage



After wall cavities have been stuffed, paneling needs to be put back into place and refastened

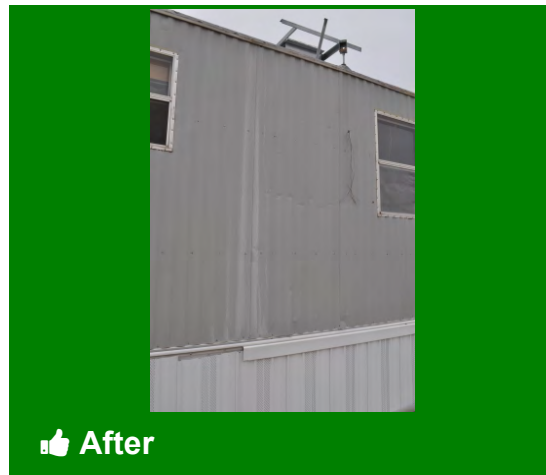

Once work is finished, reattach siding and skirting, ensuring neither have been damaged

Tools:

1. Drill

Materials:

1. Fasteners

4.1104.1f - Reattachment



Using new fasteners, reattach paneling



Reinstall skirting, if necessary



Reattach trim, if necessary



Verify that siding and skirting have not been damaged and show no signs of bulging

4.1104.1g

Desired Outcome:

Consistent thermal boundary and air barrier between the conditioned space and unconditioned space

Specification(s):

A dated receipt signed by the installer will be provided that includes:

- Coverage area
- Thickness
- R-value

Objective(s):

Document job completion to contract specifications

Confirm amount of insulation installed

Comply with 16 CFR 460.17

4.1104.2a

Desired Outcome:

Consistent thermal boundary and air barrier between the conditioned space and unconditioned space

Specification(s):

If skirting overlaps siding, skirting will be removed

Fasteners will be removed from the bottom of the siding, working upward until the siding can be pulled away from the framing approximately 6" without damaging the siding

Temporary fasteners will be installed near the bottom of the siding panels at the seams

If a subsheathing is present under the siding, access through the subsheathing will be required

Objective(s):

Gain access to the wall cavity without causing damage or separation of the siding

4.1104.2b

Desired Outcome:

Consistent thermal boundary and air barrier between the conditioned space and unconditioned space

Specification(s):

Installer prework assessment will be conducted to determine:

- Moisture damage
- Presence of infestation or pests
- Location and integrity of wiring
- Holes to the interior and exterior
- Loose paneling or siding
- Location of belt rails
- Location of wall obstructions (switches, outlets)
- Existing insulation
- Wall hangings for removal during work

Problems will be corrected before work begins

Objective(s):

Prepare wall cavity for insulation

Prevent water leaks

4.1104.2c

Desired Outcome:

Consistent thermal boundary and air barrier between the conditioned space and unconditioned space

Specification(s):

Blowing machine pressure test will be performed with air on full, feed off, and gate closed

Hose outlet pressure will be set according to manufacturer specifications

Objective(s):

Achieve uniform insulation density and coverage



In Progress

Before loading insulation, check to ensure that machine is operating properly

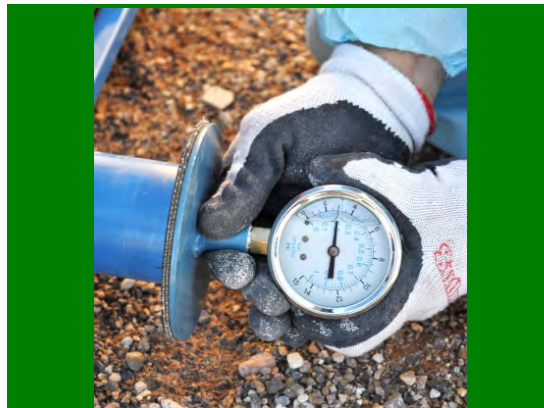

Best Practice

Test insulation blowing machine's pressure to ensure it is operating within manufacturer's parameters

Tools:

1. Pressure gauge
2. Hex wrench

4.1104.2c - Blowing machine set up



Set-up blowing machine on dry, level surface near electrical source and insulation site



Check electrical connections before operation



Make sure feed is off for testing and gate is closed

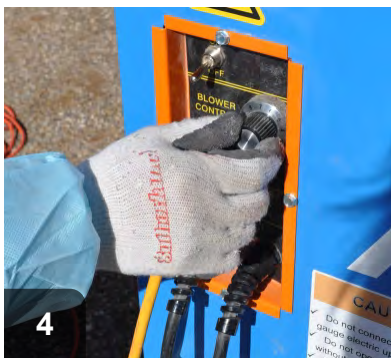

Adjust blower to full, or maximum



Using pressure gauge at feed outlet, verify that machine is working within manufacturer's specifications



If testing shows machine is operating properly, attach hose and tighten fitting to minimize slippage

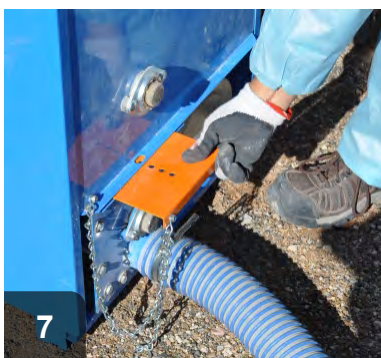

Open gate to allow for feed of insulation, turn on feed

4.1104.2d

Desired Outcome:

Consistent thermal boundary and air barrier between the conditioned space and unconditioned space

Specification(s):

Insulation will meet a flame spread rating of 25 or less and a smoke development rating of 450 or less when tested in accordance with ASTM E84

Insulation will be installed to a density of 1.5 to-1.6 pounds per cubic foot

Using fill tube, 100% of each cavity will be filled to a consistent density

Special precaution will be taken not to overfill the bottom of the cavity

Fill tube will be inserted from the bottom of the wall cavity within 6" of the top of the cavity between the interior paneling and any existing insulation

Objective(s):

Fire safety maintained

Fill entire wall cavity to the prescribed R-value to reduce air infiltration

Ensure bottom portion of siding will reattach properly

Avoid clogging of the cavity and the fill tube

4.1104.2e

Desired Outcome:

Consistent thermal boundary and air barrier between the conditioned space and unconditioned space

Specification(s):

Subsheathing will be patched or repaired as necessary

Objective(s):

Ensure the integrity of the drainage plane

4.1104.2f

Desired Outcome:

Consistent thermal boundary and air barrier between the conditioned space and unconditioned space

Specification(s):

If skirting was removed, skirting will be reinstalled to shed water to the outside of the skirting

Siding will be reattached with new fasteners

Siding will be reattached without bulges or wrinkles

Objective(s):

Ensure the integrity of the drainage plane

Reattach siding without damage

4.1104.2g

Desired Outcome:

Consistent thermal boundary and air barrier between the conditioned space and unconditioned space

Specification(s):

A dated receipt signed by the installer will be provided that includes:

- Coverage area
- Thickness
- R-value

Objective(s):

Document job completion to contract specifications

Confirm amount of insulation installed Comply with 16 CFR 460.17

4.1104.3a

Desired Outcome:

Consistent, uniform thermal boundary and air barrier between the conditioned space and unconditioned space

Specification(s):

With T-111, OSB, or plywood type siding:

- Access to exterior wall cavities will be gained and sheathing will be drilled as needed and probed to locate each cavity, wall studs, and blockers
- Drilled holes will be large enough to accommodate an appropriately sized fill tube
- Holes will be drilled around the perimeter of the home, parallel to the bottom plate and an equal distance apart
- The line of holes will be located under the lowest window sill when possible

With lap siding:

- Course of siding will be unhooked or removed
- Holes sufficiently large for the fill tube will be drilled in every wall cavity

Objective(s):

Gain access to the wall cavity

Ensure holes are easily covered with an aesthetically pleasing trim strip

4.1104.3b

Desired Outcome:

Consistent, uniform thermal boundary and air barrier between the conditioned space and unconditioned space

Specification(s):

Installer prework assessment will be conducted to determine:

- Moisture damage
- Presence of infestation or pests
- Location and integrity of wiring
- Holes to the interior and exterior
- Loose paneling or siding
- Location of belt rails
- Location of wall obstructions (switches, outlets)
- Existing insulation
- Wall hangings for removal during work

Problems will be corrected before work begins

Objective(s):

Prepare wall cavity for insulation

Prevent water leaks

4.1104.3c

Desired Outcome:

Consistent, uniform thermal boundary and air barrier between the conditioned space and unconditioned space

Specification(s):

Blowing machine pressure test will be performed with air on full, feed off, and gate closed

Hose outlet pressure will be set in accordance with manufacturer specifications

Objective(s):

Ensure machine is capable of delivering uniform insulation density and coverage



In Progress

Before loading insulation, check to ensure that machine is operating properly

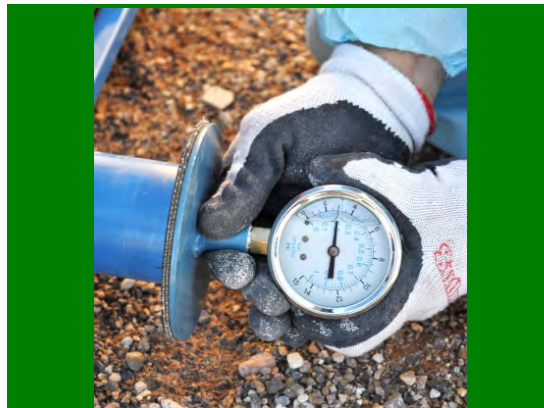

Best Practice

Test insulation blowing machine's pressure to ensure it is operating within manufacturer's parameters

Tools:

1. Pressure gauge
2. Hex wrench

4.1104.3c - Blowing machine set up



Set-up blowing machine on dry, level surface near electrical source and insulation site



Check electrical connections before operation



Make sure feed is off for testing and gate is closed

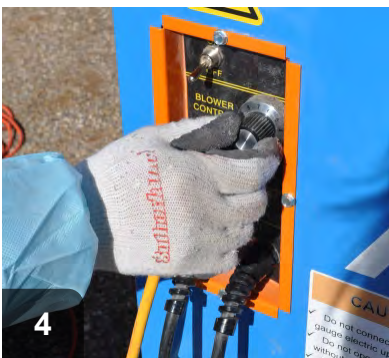

Adjust blower to full, or maximum



Using pressure gauge at feed outlet, verify that machine is working within manufacturer's specifications



If testing shows machine is operating properly, attach hose and tighten fitting to minimize slippage

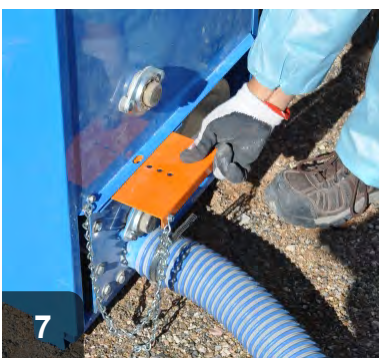

Open gate to allow for feed of insulation, turn on feed

4.1104.3d

Desired Outcome:

Consistent, uniform thermal boundary and air barrier between the conditioned space and unconditioned space

Specification(s):

Flame spread and smoke-developed index for insulation will meet a flame spread rating of 25 or less and a smoke development rating of 450 or less when tested in accordance with ASTM E84

Insulation will be installed to a density of 1.5 to 1.6 pounds per cubic foot

Using fill tube, 100% of each cavity will be filled to a consistent density

Fill tube will be inserted within 6" of the top of the cavity between the interior paneling and any existing insulation

Objective(s):

Fill entire wall cavity to the prescribed R-value to reduce air infiltration

Avoid clogging of the cavity and the fill tube

Fire safety will be maintained

4.1104.3e

Desired Outcome:

Consistent, uniform thermal boundary and air barrier between the conditioned space and unconditioned space

Specification(s):

Holes will be plugged and sealed

Objective(s):

Ensure the integrity of the drainage plane

4.1104.3f

Desired Outcome:

Consistent, uniform thermal boundary and air barrier between the conditioned space and unconditioned space

Specification(s):

For T-111 and equivalent siding:

- A preprimed trim will be centered and installed over the holes
- Height of the trim will span from 1" above to 1" below the hole
- A continuous caulk seal will be applied between the trim and siding
- Caulk seal will be above the holes
- Top edge of the trim will be sealed to the siding with a continuous caulk seal

For lap siding:

- Siding will be reattached without bulges or wrinkles
- Siding will be hooked into the original position

Objective(s):

Ensure the integrity of the drainage plane

Return siding to existing conditions without damage

4.1104.3g

Desired Outcome:

Consistent, uniform thermal boundary and air barrier between the conditioned space and unconditioned space

Specification(s):

A dated receipt signed by the installer will be provided that includes:

- Coverage area
- Thickness
- R-value

Objective(s):

Document job completion to contract specifications

Confirm amount of insulation installed

Comply with 16 CFR 460.17

4.1104.4a

Desired Outcome:

Consistent, uniform thermal boundary and air barrier between the conditioned space and unconditioned space

Specification(s):

All interior surfaces of the cavities planned to be insulated will be inspected for loose paneling joints, occupant wall hangings, and other wall obstructions

Objects will be removed from the interior surfaces of the exterior walls as needed

Interior paneling will be repaired and secured as necessary

Holes will be drilled from the interior of the house

A hole no larger than the spray nozzle will be drilled in each cavity above the door or window

When possible, the hole will be drilled in the panel groove

Objective(s):

Prepare wall cavity for insulation

Prevent damage from overspray to occupant possessions

4.1104.4b

Desired Outcome:

Consistent, uniform thermal boundary and air barrier between the conditioned space and unconditioned space

Specification(s):

Cavity will be probed to assess conditions and volume of cavity

Objective(s):

Determine the approximate amount of foam to be installed in the cavity

4.1104.4c

Desired Outcome:

Consistent, uniform thermal boundary and air barrier between the conditioned space and unconditioned space

Specification(s):

Flame spread index of foam insulation will not exceed 75 and a smoke- developed index of no more than 450 when tested in the maximum thickness intended for use in accordance with ASTM E84 or UL 723

Foam insulation will be separated from the interior of the building by an approved thermal barrier at a minimum of 1/2" gypsum wallboard or a material that is tested in accordance with the acceptance criteria of both the Temperature Transmission Fire Test and the Integrity Fire Test of NFPA 275

Two-part foam selection will be based on regional considerations

100% of each cavity will be filled to a consistent density without bulging of panels or siding

Objective(s):

Fill entire wall cavity to the prescribed R-value to reduce air infiltration

Fire safety will be maintained

4.1104.4d

Desired Outcome:

Consistent, uniform thermal boundary and air barrier between the conditioned space and unconditioned space

Specification(s):

A color-corresponding sealant will be applied to the access hole

Objective(s):

Ensure wall is aesthetically pleasing

4.1104.4e

Desired Outcome:

Consistent, uniform thermal boundary and air barrier between the conditioned space and unconditioned space

Specification(s):

A dated receipt signed by the installer will be provided that includes:

- Coverage area
- Thickness
- R-value

Objective(s):

Document job completion to contract specifications

Confirm amount of insulation installed

Comply with 16 CFR 460.17

4.1302.1a

Desired Outcome:

Belly floor cavity ready for insulation

Specification(s):

Gas, water, waste, and electrical lines will be checked for:

- Plumbing leaks
- Gas/oil leaks
- Attachment
- Standing water
- Raw sewage
- Pests

Objective(s):

Ensure that floor space is safe and ready for work

Verify scope of work

4.1302.1b

Desired Outcome:

Belly floor cavity ready for insulation

Specification(s):

Where bottom board/rodent barrier is missing or damaged and accessible, the following will be ensured:

- Duct sealing completed
- Gas, water, and electrical lines secured at least every 4' to a floor joist or framing member
- Water line will be located on the warm side of the insulation; if not, the water lines will be insulated appropriately
- No water or gas leaks are present
- Waste lines are sloped to 1/4" per foot
- Bottom board/rodent barrier is sound/strong enough to support insulation

When bottom board is intact, the following will be ensured:

- Holes and penetrations in the bottom board and decking sealed
- Duct sealing completed
- No water or gas leaks present
- Bottom board is sound/strong enough to support insulation
- Water lines are secured to the floor joists/warm side of the insulation; if not, the water lines will be insulated appropriately

Problems will be corrected before floor cavity insulation work begins

Objective(s):

Ensure problems are corrected before floor cavity insulation work begins

Keep pipes from freezing

4.1303.1a

Desired Outcome:

Consistent thermal boundary between conditioned and unconditioned space that reduces heat flow

Specification(s):

Insulation will be installed in accordance with recommended R-value and density

Objective(s):

Insulate to prescribed R-value for the climate zone

Zone	Floor
1	R13
2	R13-R19
3	R19-R25
4 to 8	R25-R30

R-value should be determined by climate zone, and be listed in work order

Area de recubrimiento pa aplicaciones de
Peso neto por

Thermal Resistance R-value Resistencia al flujo calórico Valor R	Cavity Depth/ Installed Thickness inches Espesor instalado/ Espacio de la cavidad Pulgadas	Minimum Installed Density lbs/ft ³ Densidad mínima instalada libras/p ³
13	3.5	1.0
20	5.5	
14	3.5	1.4
22	5.5	
15	3.5	1.8
23	5.5	

* BIBS = Blow-In Blanket® System; Sistema de Manto de Fibra de Vidrio al Sopló

Best Practice

Consult density chart on insulation packaging to determine proper insulation application to achieve prescribed R-value

4.1303.1b

Desired Outcome:

Consistent thermal boundary between conditioned and unconditioned space that reduces heat flow

Specification(s):

Road and rodent barrier must be intact and free from holes and capable of supporting the insulation

Objective(s):

Ensure bottom board is intact

Ensure insulation is supported

Protect cavity from infestation

4.1303.1c

Desired Outcome:

Consistent thermal boundary between conditioned and unconditioned space that reduces heat flow

Specification(s):

Each cavity will be insulated to specified R-value and density

The number of bags installed will be confirmed and will match the number required on the coverage chart

Objective(s):

Eliminate voids and settling

4.1303.1d

Desired Outcome:

Consistent thermal boundary between conditioned and unconditioned space that reduces heat flow

Specification(s):

Flame spread index of selected materials will not exceed 25 with an accompanying smoke-developed index not to exceed 450 when tested in accordance with ASTM E84 or UL 723

Flame spread index of foam insulation will not exceed 75 and a smoke- developed index of no more than 450 when tested in the maximum thickness intended for use in accordance with ASTM E84 or UL 723

Foam insulation will be separated from the interior of the building by an approved thermal barrier at a minimum of 1/2" gypsum or a material that is tested in accordance with the acceptance criteria of both the Temperature Transmission Fire Test and the Integrity Fire Test of NFPA 275

Selected material will be of minimal water absorbency

Selected material will be noncorrosive

Objective(s):

Ensure durability

Prevent moisture damage

Fire safety will be maintained

4.1303.1e

Desired Outcome:

Consistent thermal boundary between conditioned and unconditioned space that reduces heat flow

Specification(s):

A dated receipt signed by the installer will be provided that includes:

- Insulation type
- Coverage area
- R-value
- Installed thickness and minimum settled thickness
- Number of bags installed in accordance with manufacturer specifications

Objective(s):

Document job completion to contract specifications

Confirm amount of insulation installed

Ensure ability to match bags required for total area completed

Comply with 16 CFR 460.17

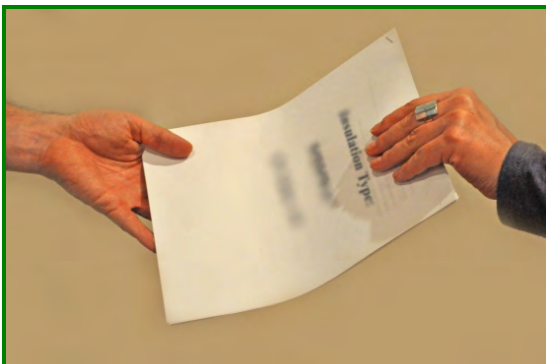

Best Practice

Provide occupant with signed, dated receipt documenting information about insulation installed

4.1303.1e - Occupant education

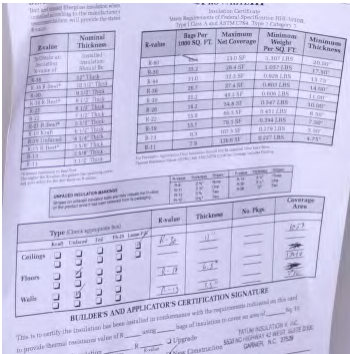

Documentation should include insulation material and r-value



Provide occupant with copies of all documentation



Communicate professionally with occupant to provide information and support

4.1303.2a

Desired Outcome:

Consistent thermal boundary between conditioned and unconditioned space that reduces heat flow

Specification(s):

Insulation will be installed in accordance with recommended R-value and density

Objective(s):

Insulate to prescribed R-value for the climate zone

Zone	Floor
1	R13
2	R13-R19
3	R19-R25
4 to 8	R25-R30

Proper r-value is determined by climate zone, and should be listed in work order



Review work order and verify that proper R-value and thickness of batt is being used

Materials:

1. Fiberglass batts

4.1303.2b

Desired Outcome:

Consistent thermal boundary between conditioned and unconditioned space that reduces heat flow

Specification(s):

Ensure complete accessibility of floor cavity

Clean floor cavities

Remove all remnants of previous insulation and bottom board

Objective(s):

Ensure work area is clean, safe, and ready to accept insulation



 Before

Cavity spaces that are to be insulated need to be cleared of old insulation and debris



 After

Once cavity is cleared, it is ready for new insulation

Tools:

1. Utility knife

4.1303.2b - Work assessment



1 Remove old rodent barrier and insulation



2 Cavities should be completely cleared of debris

4.1303.2c

Desired Outcome:

Consistent thermal boundary between conditioned and unconditioned space that reduces heat flow

Specification(s):

Each cavity will be insulated to specified R-value and density

If insulation has facing, facing will be in contact with the heated side

Insulation will be in contact with subfloor

Insulation will not have gaps, voids, or be compressed

Insulation will be supported (e.g., metal insulation supports) to maintain a permanent contact with subfloor

Insulation will be notched around all wires, pipes, and blocks

Ducts and water lines will be insulated for climate conditions

Water lines will be located above the warm side of the insulation (toward the conditioned space), when feasible

A rigid air barrier will be installed in contact with the bottom of the joists, when feasible

Rigid air barrier will be fastened as to not sag, bend, or fall off

Seams, holes, and joints in the air barrier will be sealed

In cases where HVAC ducts hang below the level of the rigid air barrier and insulation, the ducts will be insulated and air barrier provided that is sealed to the rigid air barrier

Objective(s):

Eliminate voids

Minimize conductive heat transfer across the floor system

Ensure durability

Minimize convective heat transfer

Keep pipes from freezing

**Before**

Uninsulated floors over unconditioned spaces are an energy drain

**After**

In addition to fiberglass batt insulation, a rigid air barrier will be sealed and mechanically fastened in place

Tools:

1. Utility knife
2. Tape measure
3. Metal snips
4. Drill
5. Caulk gun

Materials:

1. Fiberglass batts, may be kraft-faced
2. Metal tape
3. Insulation supports (lightning rods)
4. Fasteners
5. Caulk
6. Duct insulation

4.1303.2c - Insulate floors



1 If fiberglass insulation is kraft-faced, ensure kraft is in contact with subfloor

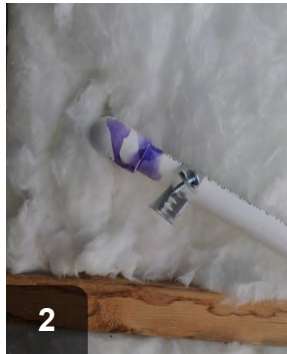

2 Notch insulation around pipes, blocks, and other obstructions

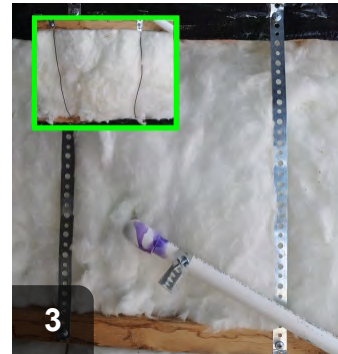

3 To prevent insulation from moving away from subfloor, supports should be fastened in place



4 A rigid air barrier should be securely in place so prevent sagging, gaps and penetrations should be sealed



5 When ductwork or water pipes run below joists, insulation should be threaded above to fill joist cavity, uncompressed



6 Water lines and ducts should be insulated if running below joists



7 A rigid air barrier should be mechanically fastened to hold it tight against the floor joists



8 When insulating around low-hanging ducts and water pipes, run a line of sealant before placing insulation



9 Insulation around ducting should be securely fastened and sealed to maintain air barrier

4.1303.2d

Desired Outcome:

Consistent thermal boundary between conditioned and unconditioned space that reduces heat flow

Specification(s):

Insulation materials will be of minimal water absorbency and flame spread, and smoke-developed index for insulation will be in accordance with 2012 IRC 2012, Sections R302.10.1 through R302.10.5

Foam plastic insulation will comply with 2012 IRC 2012, Section R316

Fasteners will be corrosion resistant

Objective(s):

Ensure durability

Prevent moisture damage



Bad Practice

Do not use absorbent insulation material, such as cellulose, in the floor cavity



Best Practice

Fiberglass batts are a good choice for insulating floor cavities

Materials:

1. XPS insulation board
2. Fiberglass batts
3. Corrosion resistant exterior screws

4.1303.2d - Materials

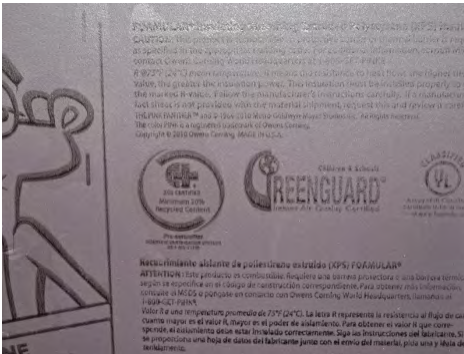

XPS insulation board is a non-absorbent insulation option



XPS (extruded polystyrene) is safe for use in floor cavities



Do not use EPS (expanded polystyrene) foam board in floor cavities due to flame spread rate



Use only corrosion resistant, exterior screws as fasteners in floor cavities

4.1303.2e

Desired Outcome:

Consistent thermal boundary between conditioned and unconditioned space that reduces heat flow

Specification(s):

A dated receipt signed by the installer will be provided that includes:

- Coverage area
- Thickness
- R-value

Objective(s):

Document job completion to contract specifications

Confirm amount of insulation installed

Comply with 16 CFR 460.17



Best Practice

Provide occupant with signed, dated receipt documenting information about insulation installed

4.1303.2e - Occupant education

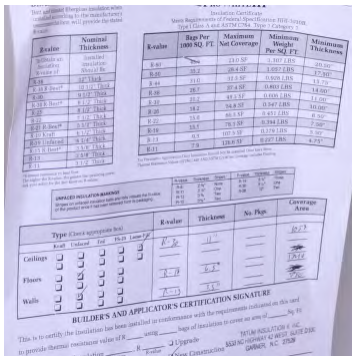

Documentation should include insulation material and r-value



Provide occupant with copies of all documentation



Communicate professionally with occupant to provide information and support

4.1303.3a

Desired Outcome:

Installation of a consistent thermal boundary between conditioned and unconditioned space that reduces heat flow

Specification(s):

Insulation will be installed in accordance with recommended R-value

Objective(s):

Insulate to prescribed R-value for the climate zone

4.1303.3b

Desired Outcome:

Installation of a consistent thermal boundary between conditioned and unconditioned space that reduces heat flow

Specification(s):

Ensure complete accessibility of floor cavity

Objective(s):

Ensure work area is clean, safe, and ready to accept insulation

4.1303.3c

Desired Outcome:

Installation of a consistent thermal boundary between conditioned and unconditioned space that reduces heat flow

Specification(s):

All floor areas will be open and accessible for spray foam application

Any openings in the subfloor larger than ¼" will be covered with appropriate materials

Insulation dams or end blockers will be installed where needed

All surfaces where spray foam is applied will be clean, dry, and free of contamination and degradation

Substrate surfaces will be wiped, blown, or vacuumed to be free of excessive dust and dirt

Grease and oil will be removed using appropriate cleaners or solvents

Moisture content of all wood substrate materials will be below 19%; if tested at or above this percent of moisture, insulating the floor will be deferred until moisture level is corrected

Clean floor cavities

Remove all remnants of previous insulation and bottom board

Objective(s):

Prepare all substrate surfaces for the application of spray foam

4.1303.3d

Desired Outcome:

Installation of a consistent thermal boundary between conditioned and unconditioned space that reduces heat flow

Specification(s):

Insulation will be installed to prescribed R-value in accordance with manufacturer specifications

In accordance with manufacturer specifications, spray foam will be applied to desired thickness using the maximum pass thickness onto subfloor between floor joists and all rim/band joists

Rim/band joist will be sealed

When desired, underside of joists will be covered with spray foam to provide a layer of continuous insulation

Each cavity will be insulated to specified R-value

Insulation must be in contact with subfloor

Insulation will not have gaps or voids

Ducts and water lines will be insulated for climate conditions

Objective(s):

Insulate and seal floors

Eliminate voids

Minimize conductive and convective heat transfer across the floor system

Ensure durability

4.1303.3e

Desired Outcome:

Installation of a consistent thermal boundary between conditioned and unconditioned space that reduces heat flow

Specification(s):

Insulation will be installed in accordance with manufacturer specifications

Flame spread index of selected materials will not exceed 25 with an accompanying smoke-developed index not to exceed 450 when tested in accordance with ASTM E 84 or UL 723

Flame spread index of foam insulation will not exceed 75 and a smoke-developed index of no more than 450 when tested in the maximum thickness intended for use in accordance with ASTM E 84 or UL 723

Foam insulation will be separated from the interior of the building by an approved thermal barrier at minimum 1/2" gypsum or a material that is tested in accordance with the acceptance criteria of both the Temperature Transmission Fire Test and the Integrity Fire Test of NFPA 275

Objective(s):

Ensure durability

Ensure worker safety

Ensure proper installation

Fire safety will be maintained

4.1303.3f

Desired Outcome:

Installation of a consistent thermal boundary between conditioned and unconditioned space that reduces heat flow

Specification(s):

Spray foam will be separated from the occupied space of the building with a 15-minute thermal barrier (typically 15/32" sheathing, 1/2" gypsum board, or approved thermal barrier coating) or as approved by ASTM E84 requirements

Spray foam designed to be used as a fire block does not require a thermal barrier installed prior to application

Objective(s):

Provide necessary fire protection for combustible spray foam insulation

4.1303.3g

Desired Outcome:

Installation of a consistent thermal boundary between conditioned and unconditioned space that reduces heat flow

Specification(s):

A dated receipt signed by the installer will be provided that includes:

- Coverage area
- Thickness
- R-value

Objective(s):

Document job completion to contract specifications

Confirm amount of insulation installed

Comply with 16 CFR 460.17



Best Practice

Provide occupant with signed, dated receipt documenting information about insulation installed

4.1303.3g - Occupant education

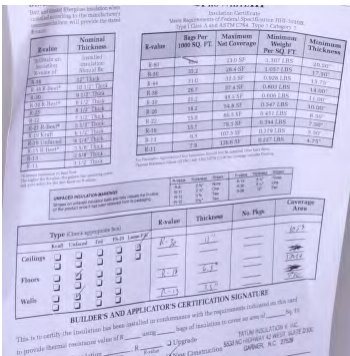

Documentation should include insulation material and r-value

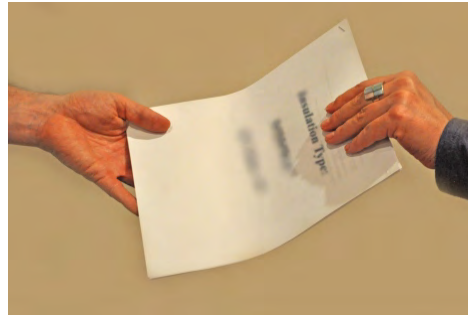

Provide occupant with copies of all documentation



Communicate professionally with occupant to provide information and support

4.1402.2a

Desired Outcome:

Basement insulation improves thermal performance and ensures sufficient drying potential

Specification(s):

Regional IECC will be followed for required R-values

Objective(s):

Improve thermal performance of the basement and living space

	Continuous Rigid Insulation, Interior or Exterior	Interior Cavity Insulation
Zone 1	0	0
Zone 2	0	0
Zone 3	5	13
Zone 4, except marine	10	13
Zone 5 and marine 4	15	19
Zone 6-8	16	19

Best Practice

Find your regional zone and insulation application to determine r-value

4.1402.2b

Desired Outcome:

Basement insulation improves thermal performance and ensures sufficient drying potential

Specification(s):

A continuous air barrier will be installed on the warm side of the insulation

Objective(s):

Prevent condensation on the basement wall



 Before

Basement shows no sign of ground water penetration, but needs insulation



 After

Insulation and drywall create an air barrier

Tools:

1. Utility knife
2. Tape measure
3. Drill
4. Taping knife

Materials:

1. XPS insulation board
2. Kraft-faced fiberglass batts
3. Drywall
4. Spackle
5. Seam tape
6. Fasteners

4.1402.2b - Air barrier



XPS insulation board is a non-absorbent insulation option



The drywall still provides an air barrier to keep moisture build up on wall



OR Kraft-faced fiberglass batts can be used with paper toward living space



Both kraft-face and drywall create air barrier, but batts are absorbent

4.1402.2c

Desired Outcome:

Basement insulation improves thermal performance and ensures sufficient drying potential

Specification(s):

When absorbent insulation materials are installed, assembly will remain vapor permeable to the interior in all climate zones except Zone 7 (<http://energycode.pnl.gov/EnergyCodeReqs/>)

Objective(s):

Provide drying potential to the basement



Kraft-faced fiberglass insulation is absorbent



Drywall typically has a perm rating of 50--good for zones 1-6

Tools:

1. Utility knife
2. Tape measure
3. Drill
4. Taping knife

Materials:

1. XPS insulation board
2. Drywall
3. Kraft-faced fiberglass batts
4. Spackle
5. Seam tape
6. Fasteners

The higher a material's perm rating, the more vapor can pass through said material. Drywall typically has a perm rating of approximately 50.

In zones 7 & 8 (AK, parts of MN, ND, WI, MI, WY, CO, and ME), vapor retarders should be used to minimize freezing. For vapor retarders in basements and crawl spaces, SWS calls for materials with a perm rating of <math><0.5</math> (which translates to 4mil or thicker). From 2007 IRC definition of vapor retarders: Class I: ≤ 0.1 perm (called impermeable), Class II: 0.1 to 1.0 perm (called semi-impermeable), Class III: 1.0 perm to 10 perms (called semi-permeable).

4.1402.2c - Vapor permeability

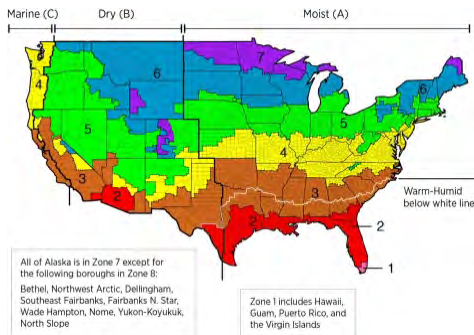

Determine in which zone you are working before selecting work materials

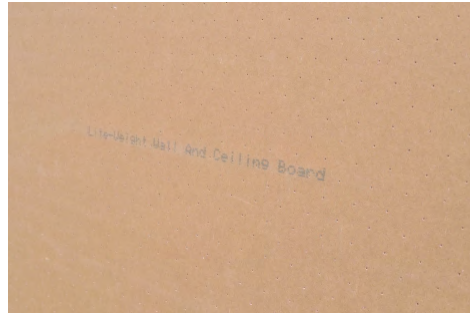

Many light-weight drywall brands have higher perm ratings for humid zones



In zones 7&8, vapor permeability is undesirable. Use a vapor retarder

4.1402.3a

Desired Outcome:

Basement insulation improves thermal performance and ensures sufficient drying potential

Specification(s):

A continuous drainage plane at the interior surface of the exterior basement wall will be created from the top of the wall to a drainage field at the bottom of the wall or sub-slab

Drainage field will be run to daylight or pumped to the outside

Objective(s):

Remove moisture on the surface of the exterior basement wall

4.1402.3b

Desired Outcome:

Basement insulation improves thermal performance and ensures sufficient drying potential

Specification(s):

Drainage plane will be replaced with a waterproof membrane

Only a nonabsorbent insulation that complies with ASTM C665-06 will be applied

Insulation will adhere to the waterproof membrane without voids

Drainage field will be run to daylight or pumped to the outside

Objective(s):

Create an air and moisture barrier on the interior side of the exterior basement wall and allow the insulation to conform to the irregularity of the surface

Improve thermal performance of the basement and the living space

4.1402.3c

Desired Outcome:

Basement insulation improves thermal performance and ensures sufficient drying potential

Specification(s):

A nonabsorbent insulation will be used with a minimum expected service life of 10 years

A fire-rated material will be used if the insulation is left exposed

Objective(s):

Improve thermal performance of the basement and the living space

4.1402.3d

Desired Outcome:

Basement insulation improves thermal performance and ensures sufficient drying potential

Specification(s):

Insulation will be installed continuously from the top of the band joist to the top of the slab

Objective(s):

Maintain a continuous thermal boundary on the interior side of the exterior basement wall

4.1402.3e

Desired Outcome:

Basement insulation improves thermal performance and ensures sufficient drying potential

Specification(s):

Where termite pressure exists, if subslab drainage is installed, termite treatment will be performed before reinstalling the slab

Objective(s):

Provide termite protection

4.1402.3f

Desired Outcome:

Basement insulation improves thermal performance and ensures sufficient drying potential

Specification(s):

Insulation will be attached with a durable connection equal to or better than the manufacturer specifications, whichever is more durable

A minimum expected service life of 10 years will be ensured

Objective(s):

Secure thermal boundary without compromising the insulation

4.1402.3g

Desired Outcome:

Basement insulation improves thermal performance and ensures sufficient drying potential

Specification(s):

Regional IECC will be followed for required R-value

Objective(s):

Improve thermal performance of the basement and living space

	Continuous Rigid Insulation, Interior or Exterior	Interior Cavity Insulation
Zone 1	0	0
Zone 2	0	0
Zone 3	5	13
Zone 4, except marine	10	13
Zone 5 and marine 4	15	19
Zone 6-8	16	19

Best Practice

Find your regional zone and insulation application to determine r-value

4.1402.3h

Desired Outcome:

Basement insulation improves thermal performance and ensures sufficient drying potential

Specification(s):

A continuous air barrier on the warm side of the thermal boundary will be installed, including floor-to-wall and wall-to-ceiling connections

Objective(s):

Prevent convective air leakage from the basement, through the drainage plane, and back into the basement

4.1402.3i

Desired Outcome:

Basement insulation improves thermal performance and ensures sufficient drying potential

Specification(s):

International Residential Code (2012 IRC) will be followed for finished wall details in basements

Objective(s):

Install a durable, finished wall

4.1402.3j

Desired Outcome:

Basement insulation improves thermal performance and ensures sufficient drying potential

Specification(s):

A dated receipt signed by the installer will be provided that includes:

- Coverage area
- Thickness
- R-value

Objective(s):

Document job completion to contract specifications

Confirm amount of insulation installed

Comply with 16 CFR 460.17

4.1488.1a

Desired Outcome:

Water supply line does not freeze in cold climates

Specification(s):

Installer prework assessment will be conducted to determine:

- Water leaks do not exist
- Accessibility

Water leaks will be repaired before installation

Objective(s):

Verify scope of work

Ensure that work space is safe and ready for work

4.1488.1b

Desired Outcome:

Water supply line does not freeze in cold climates

Specification(s):

Pipe freeze protection system will have thermostatic heat control and circuit protection

Insulation will be installed over pipe freeze protection system when necessary

Pipe will be protected from wind

Objective(s):

Ensure fire safety

Protect supply pipe from freezing



In Progress

Properly installed freeze protection heat tape

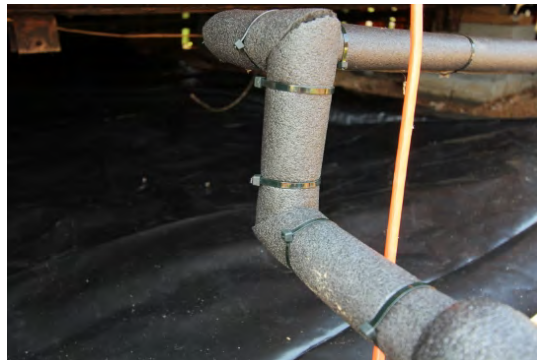

After

Insulated, freeze protected water line

Tools:

1. Utility knife
2. Rags

Materials:

1. Heat tape
2. Zip ties (to attach thermostat)
3. Electrical tape
4. 1/2" thick fiberglass insulation

To prevent pipe freezing and reduce the risk of fire, follow manufacturer's instructions carefully. Choose the proper length heat tape for the pipe to be protected. When using multiple lengths of heat tape on long pipes, start subsequent runs of heat tape one foot before the end of the previous run on opposite sides of the pipe. Never overlap or cross heat tape with itself. Complete heat tape installation instructions may be found here: <https://www.foremost.com/mygreathome/mobile-home-repair/seasonal/how-to-install-heat-tape.asp>

4.1488.1b - Installation



1 Install thermostat in firm contact with the pipe at the coldest point



2 Fasten heat tape to pipe with electrical tape every six inches.



3 Measure and cut insulation to fit water lines. Miter insulation at elbows and tees



4 Fasten insulation to water lines with zip ties

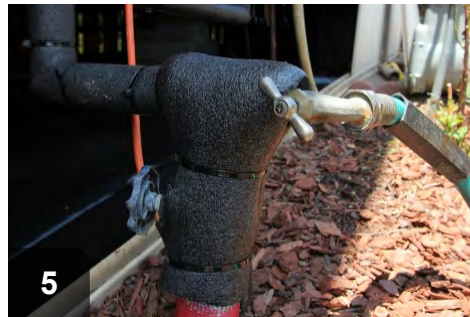

5 Cover all exposed portions of the water supply lines with insulation

4.1488.1c

Desired Outcome:

Water supply line does not freeze in cold climates

Specification(s):

Occupants will be educated on efficient and safe operation and maintenance of heat tape

Objective(s):

Ensure safe and durable protection of water line



Educate occupant on effective and safe use of heat tape

Materials:

1. Heat tape manufacturer's operating instructions

A good guide for homeowner education may be found here:

<https://www.foremost.com/mygreathome/mobile-home-repair/seasonal/how-to-install-heat-tape.asp>

4.1601.3a

Desired Outcome:

Minimize condensation

Specification(s):

Ducts will have continuous insulation and vapor barrier

Insulation will be sufficient to prevent dew point on surface of ducts

Objective(s):

Minimize condensation

4.1601.3b

Desired Outcome:

Minimize condensation

Specification(s):

Inspection and/or testing will be conducted to determine whether ducts are within thermal, pressure, and vapor boundary

If ducts are within thermal, pressure, and vapor boundary, no action will be required

If ducts are not within thermal, pressure, and vapor boundary, continuous air barrier, insulation, and vapor retarder will be installed either on the ducts or at the belly liner

Objective(s):

Minimize condensation

4.1601.3c

Desired Outcome:

Minimize condensation

Specification(s):

All exposed metal will have continuous insulation and vapor retarder

Objective(s):

Minimize condensation

4.1601.4a

Desired Outcome:

Lower conductive heat transfer by ducts and decrease condensation on duct vapor barrier

Specification(s):

All accessible low R-value flexible ducting will be removed from premises

Objective(s):

Ensure installation of proper R-value ducts



Before

Remove existing flex duct that does not meet the requirement of R-8.0



Best Practice

Replace with ducting insulated to a minimum of R-8

4.1601.4b

Desired Outcome:

Lower conductive heat transfer by ducts and decrease condensation on duct vapor barrier

Specification(s):

All flexible ducting will have a minimum of R-8

Objective(s):

Minimize thermal conductance through the duct system



Existing flex duct that does not meet the requirement of R-8.0 should be removed



All replacement ducting should be R-8.0, minimum

Tools:

1. Tie band tensioner

Materials:

1. Flex duct, min R-8

4.1601.4c

Desired Outcome:

Lower conductive heat transfer by ducts and decrease condensation on duct vapor barrier

Specification(s):

Duct-sizing procedures will be conducted when replacing flex duct

Objective(s):

Improve comfort in rooms

Improve fan performance

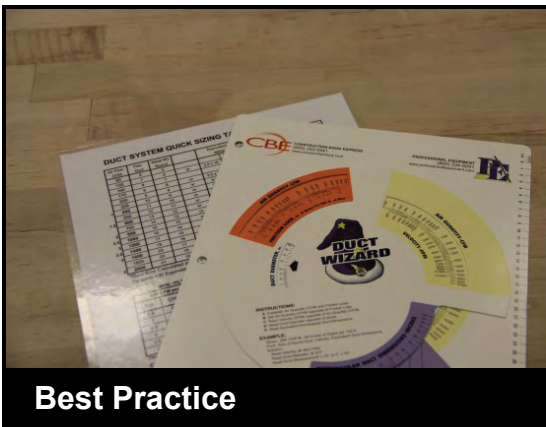

Best Practice

Ducts should be sized according to how much airflow is needed for a room.

Tools:

1. Duct-u-lator or ACCA equivalent

4.1601.4d

Desired Outcome:

Lower conductive heat transfer by ducts and decrease condensation on duct vapor barrier

Specification(s):

Flex duct will be supported in accordance with flex duct manufacturer's directions or local codes

Beaded rigid elbow or equivalent will be installed in duct runs whenever change in direction is required

Objective(s):

Prevent sags, drops, or other bends that may interfere with correct air flow

Maintain duct diameter around the turns

Maximize air flow and distribution



Best Practice
Straps should be at least 1.5" wide.



After
Straps should be placed in accordance with manufacturers specification, typically 4ft.

Materials:

1. 1.5" webbing or strap material

4.1601.4d - Installation of flex



Elbows are required when a change in direction is needed.

4.1601.4e

Desired Outcome:

Lower conductive heat transfer by ducts and decrease condensation on duct vapor barrier

Specification(s):

Interior liner of the flex-to-metal connection will be fastened with tie bands using a tie band tensioning tool

For oval flexible duct-to-metal connections, tie bands cannot be used; appropriate mechanical fasteners will be used

Objective(s):

Create a strong, secure attachment



Before

Duct liner has been sealed, but tie band has not been installed.



After

Liner has been securely fastened with tie band tensioning tool.

Tools:

1. tie band tensioning tool

Materials:

1. tie band

4.1601.4f

Desired Outcome:

Lower conductive heat transfer by ducts and decrease condensation on duct vapor barrier

Specification(s):

UL 181 B-M-listed mastic product will be used to seal the connection

Objective(s):

Create an airtight connection



Best Practice

Using a product like the mastic shown here results in an airtight connection

Materials:

1. UL 181 B-M listed mastic product

4.1601.4g

Desired Outcome:

Lower conductive heat transfer by ducts and decrease condensation on duct vapor barrier

Specification(s):

Liner will be pulled up onto the metal duct as far as possible before securing

The exterior liner of the flex duct will be fastened with tie bands using a tie band tensioning tool

Objective(s):

Create a strong, durable attachment



Pull the outer liner so that all exposed surfaces are covered.

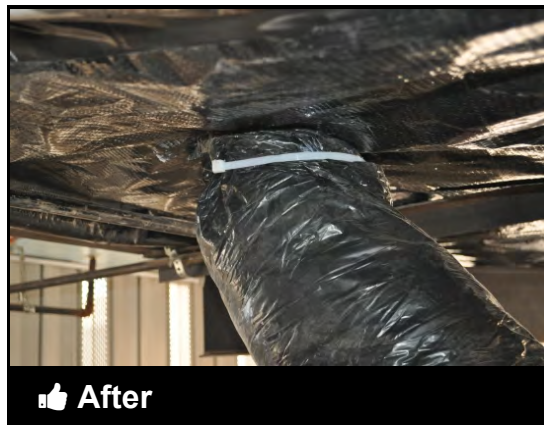

Duct is properly secured with a trimmed tie band.

Tools:

1. tie band tensioning tool

Materials:

1. tie band

4.1601.4g - Attachment of exterior liner



Outer liner should be pulled up to cover all un-insulated surfaces.



Secure the tie band in place by hand or using a tie band tension tool.



Trim the excess tie band material.

4.1601.4h

Desired Outcome:

Lower conductive heat transfer by ducts and decrease condensation on duct vapor barrier

Specification(s):

All accessible joints, seams, and connections will be sealed with UL 181 approved mastics

Objective(s):

Minimize duct leakage



In Progress

Here the technician is inspecting work in progress, ensuring a good seal.



After

The duct boot has been properly sealed, even though the area is difficult to reach.

Tools:

1. inspection mirror

Materials:

1. mastic
2. duct boot

4.1601.4i

Desired Outcome:

Lower conductive heat transfer by ducts and decrease condensation on duct vapor barrier

Specification(s):

All metal fittings, including boots, elbows, and takeoffs, will be insulated separately using a minimum of R-8 duct wrap with a vapor barrier mechanically fastened (e.g., stitch staples, tie bands) and sealed with no exposed metal

Objective(s):

Minimize thermal conductance of the duct system

Minimize condensation



 Before

This elbow has been sealed, but is not insulated.



 After

Fitting has been sealed and properly insulated.

4.1601.4j

Desired Outcome:

Lower conductive heat transfer by ducts and decrease condensation on duct vapor barrier

Specification(s):

Vapor barrier of all duct insulation will be taped to the flex duct using the taping system required by the manufacturer of the duct insulation

Vapor barrier will be sealed to the belly liner

Objective(s):

Ensure a complete vapor barrier



Crossover duct with vapor barrier mended and sealed to manufactured home belly

Tools:

1. Reusable spray foam gun
2. Utility knife
3. Scissors
4. Outward clinching (stitch) stapler

Materials:

1. UL-181 B-M foil or Mylar tape
2. Foam sealant
3. Staples

Clean vapor barrier thoroughly before applying UL 181B Mylar tape to cuts and seams. Repair belly if necessary, and use foam sealant to seal the vapor barrier to the belly.

4.1601.4k

Desired Outcome:

Lower conductive heat transfer by ducts and decrease condensation on duct vapor barrier

Specification(s):

Vermin access points will be identified and treated appropriately (e.g., seal access holes)

Objective(s):

Ensure long-term durability of the building materials



 Before

Flexible ducts are susceptible to vermin entry.



 After

Flex that has been damaged by vermin entry must be replaced or repaired.

4.1601.4I

Desired Outcome:

Lower conductive heat transfer by ducts and decrease condensation on duct vapor barrier

Specification(s):

CAZ testing will be performed where combustion appliances are utilized

Objective(s):

Identify unsafe equipment operating conditions



Complete combustion appliance zone testing to ensure a healthy, safe environment

Tools:

1. Manometer
2. Mirror
3. Chemical smoke pencil
4. Stopwatch or watch with second hand
5. Gas leak detector
6. Combustion analyzer
7. 1/4" air line tubing

At the end of each day in which duct sealing or repair is performed, conduct Combustion Appliance Zone (CAZ) testing in accordance with the NREL Manufactured Home Standard Work Specifications, details 2.0201.3a through 2.0201.3h.

4.1601.5a

Desired Outcome:

Lowered thermal conductance of duct system and minimized condensation on the duct system

Specification(s):

Duct insulation will be a minimum of R-8, in accordance with local code or buried under attic insulation, whichever is a greater R-value, and have an attached and continuous vapor barrier

Hot humid and warm coastal regions will not bury ducts

Objective(s):

Decrease heat loss and condensation problems



 Before

Uninsulated ducts in unconditioned spaces are an energy drain



 After

Properly insulated ducts operate at much higher rates of efficiency

4.1601.5a - Selection of duct insulation material



Ducts in unconditioned areas should have r-8 insulation with vapor barrier



OR ducts can be buried in loose fill in attic spaces in drier climates

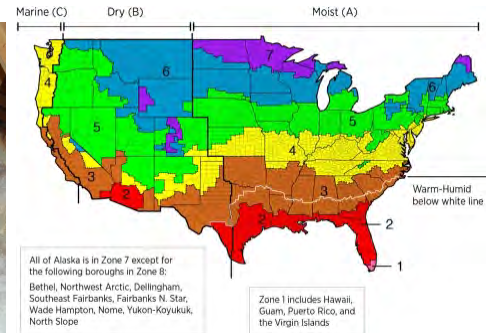

Burying ducts is discouraged in warm coastal and hot humid regions

4.1601.5b

Desired Outcome:

Lowered thermal conductance of duct system and minimized condensation on the duct system

Specification(s):

All accessible ducts will be sealed with a UL-181 mastic before insulation is applied

Objective(s):

Minimize duct leakage



 Before

Unsealed joints and connections need to be sealed to prevent health risks



 After

Sealed ductwork connections help prevent leakage

Tools:

1. Putty knife

Materials:

1. UL-181 mastic
2. Fiberglass mesh tape

4.1601.5b - Duct sealing



1 Prepare work area by assessing any safety concerns

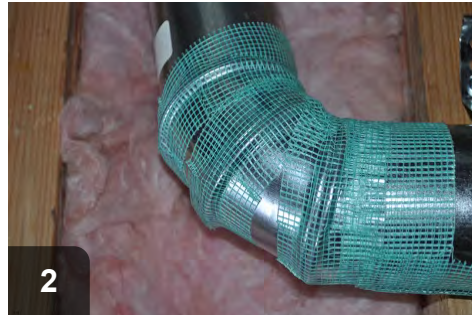

2 Wrap joint with fiberglass mesh tape



3 Apply UL 181 mastic to seal joint

4.1601.5c

Desired Outcome:

Lowered thermal conductance of duct system and minimized condensation on the duct system

Specification(s):

Duct insulation will be mechanically fastened (e.g., stitch staples, tie bands) and sealed with no exposed metal

Duct insulation will be secured to the duct system using metal wire or rot-proof nylon twine

Pattern of the wire or twine will be sufficient to securely hold the duct insulation tight to the duct

Mechanical fastening will be sufficient to securely hold the duct insulation in place and tight to the duct

Objective(s):

Ensure a secure connection between the duct system and the duct insulation

Ensure performance of the installed material

Minimize condensation



Materials holding insulation in place should not compress or kink duct



Durable materials can be attached without compressing insulation

Tools:

1. Scissors
2. Metal snips

Materials:

1. Nylon twine
2. Wire
3. Tie bands

4.1601.5d

Desired Outcome:

Lowered thermal conductance of duct system and minimized condensation on the duct system

Specification(s):

Using a tape approved by the manufacturer, all seams and connection of the vapor barrier will be taped so that no metal is exposed

No gaps will exist between pieces of duct insulation

Objective(s):

Prevent gaps in the vapor barrier of the insulation



 Before

Unsecured and sealed insulation around ducts is useless



 After

All seams should be sealed with UL-181 duct tape to preserve vapor barrier

Tools:

1. Utility knife

Materials:

1. UL-181 tape
2. R-8 duct insulation with vapor barrier

4.1601.5e

Desired Outcome:

Lowered thermal conductance of duct system and minimized condensation on the duct system

Specification(s):

Vermin access points will be identified and treated appropriately (e.g., seal access holes)

Objective(s):

Ensure long-term durability of the building materials

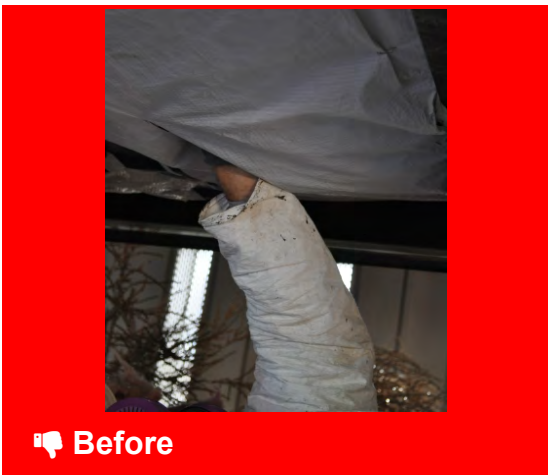

Holes in air barrier should be patched to deter vermin

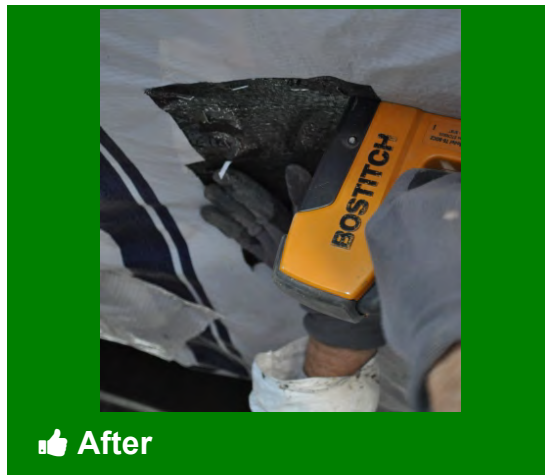

Ensure that patch is well sealed and securely fastened

4.1601.5e - Vermin proofing



Holes in ducting should be patched to discourage vermin



Holes in belly air barriers allow vermin access to insulation and ducting

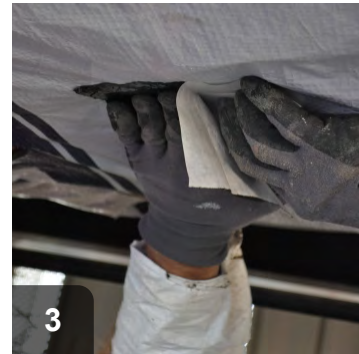

Use adhesive patch to air seal

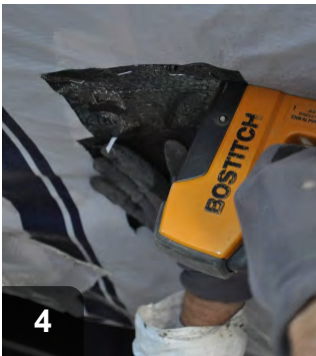

Stitch staple patch to securely fasten physical barrier



Stitch staples bend outward to hold in place for the long-term

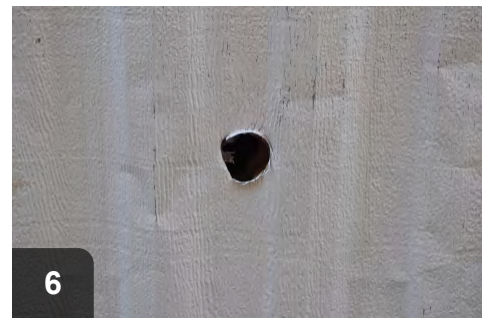

Holes in exterior walls are another point of vermin entry



Apply sealant to back of patch to maintain air barrier



Flex patch to contour to wall



Securely fasten patch in place with screws and apply addition sealant to deter water

4.9901.1a

Desired Outcome:

To provide general Information on spray polyurethane foam

Specification(s):

Low-pressure SPF systems are two-component polyurethane foam products. They are typically delivered to the job site in pressurized canisters (~250 psi), dispensed through unheated hoses through a disposable mixing nozzle system, and applied as a froth-like material to substrate. This type of SPF product is typically used for large sealing and small-scale insulation products.

Objective(s):

To provide general Information on spray polyurethane foam

4.9901.1b

Desired Outcome:

To provide general Information on spray polyurethane foam

Specification(s):

High-pressure SPF systems are two-component polyurethane foam products. They are typically delivered to the job site in unpressurized drums or totes, and dispensed by a proportioner pump where heat and pressure are added. These chemicals travel through heated hoses to a spray gun where the material is aerosolized during application. This type of SPF product is typically used for larger insulation applications.

Once installed, there is essentially no difference in product performance between low- and high-pressure foams. It should be noted that the main differences between the delivery methods are in capital equipment investment, application rate, and PPE requirements.

Applicators should obtain training from the suppliers of SPF to help assure installation quality and use of all equipment as well as safe handling, use, and disposal of all chemicals used in the process. Spray Polyurethane Foam Alliance (SPFA) also offers additional training and accreditation for high-pressure SPF applicators.

Objective(s):

To provide general Information on spray polyurethane foam

4.9901.1c

Desired Outcome:

To provide general Information on spray polyurethane foam

Specification(s):

In addition to the guidelines above, SPF applicators should follow all manufacturer installation instructions for the product being used. These instructions include product-specific documents, such as application instructions, MSDSs, and evaluation reports.

Objective(s):

To provide general Information on spray polyurethane foam

5.3001.3a

Desired Outcome:

Effective, efficient, safe, and durable return air system

Specification(s):

Existing return air openings will be closed off and sealed with a durable material equivalent in strength to the surrounding material

Disturbed materials suspected to contain asbestos or lead content will be assessed and removed in accordance with EPA regulations

Objective(s):

Minimize air leakage

Improve indoor environmental quality

Ensure safe and legal renovation

5.3001.3b

Desired Outcome:

Effective, efficient, safe, and durable return air system

Specification(s):

Alternate return air opening will be provided to the furnace closet (e.g., replace louvered door or install grilles); whenever possible, follow manufacturer specifications for amount needed

Return duct design will be in accordance with ANSI/ACCA 1 Manual D Residential Duct Systems

A continuous and adequate return air pathway to the air handler will be installed

Objective(s):

Ensure sufficient return air is provided to the system

5.3001.3c

Desired Outcome:

Effective, efficient, safe, and durable return air system

Specification(s):

Pressures will be measured with the furnace fan operating across interior doors that can be closed and have a supply and/or return behind them

Rooms should not exceed 3 pascals of pressure

Pressure testing will be performed with all interior doors closed and the air handler running

Objective(s):

Ensure sufficient return air is provided to the system

Minimize moisture intrusion from negative pressures

Improve indoor air quality

5.3001.3d

Desired Outcome:

Effective, efficient, safe, and durable return air system

Specification(s):

CAZ testing will be performed where combustion appliances are utilized

Objective(s):

Identify unsafe equipment operating conditions



Complete combustion appliance zone testing to ensure a healthy, safe environment

See
**SWS 2.0201.3a-
2.0201.3h
for CAZ testing**

Tools:

1. Manometer
2. Mirror
3. Chemical smoke pencil
4. Stopwatch or watch with second hand
5. Combustion analyzer
6. 1/4" air line tubing
7. Gas leak detector

At the end of each day in which duct sealing or repair is performed, conduct Combustion Appliance Zone (CAZ) testing in accordance with the NREL Manufactured Home Standard Work Specifications, details 2.0201.3a through 2.0201.3h.

5.3001.3e

Desired Outcome:

Effective, efficient, safe, and durable return air system

Specification(s):

Occupant will be educated on changes, how to operate and maintain the system, and any potential health concerns (e.g., lead, asbestos)

Objective(s):

Ensure occupant is educated

5.3003.1a

Desired Outcome:

Data for commissioning and future service work is recorded

Specification(s):

Equipment will be visually inspected

Information will be recorded from the equipment data plates indoors and outdoors

Objective(s):

Ensure technician has equipment data necessary for commissioning and future service work

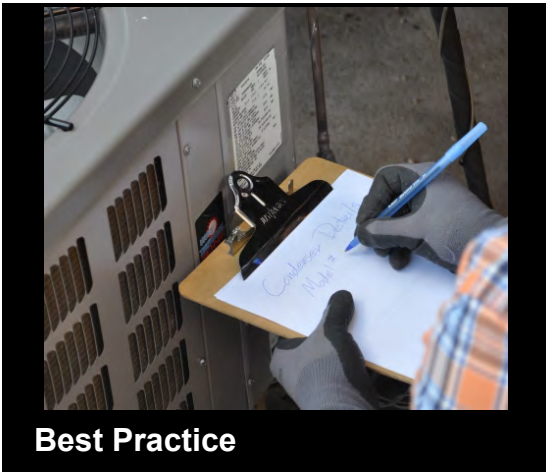

Best Practice

Complete a visual inspection of all heating and cooling equipment

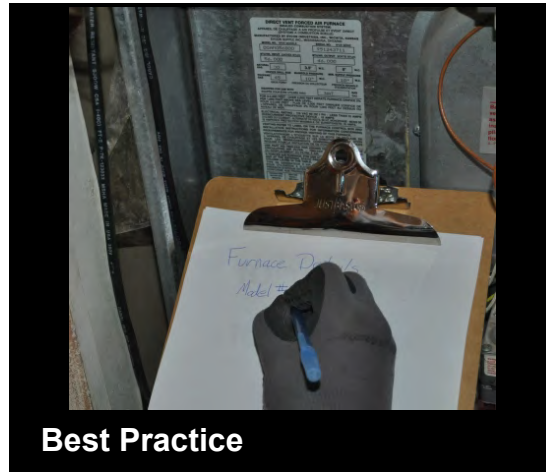

Best Practice

Record model information about heating and cooling equipment to ensure proper maintenance

5.3003.3a

Desired Outcome:

Air flow is properly tested

Specification(s):

Total system air flow will be measured by:

- Temperature rise
- Flow plate
- Fan depressurization device (e.g., Duct Blaster, DucTester)

Objective(s):

Ensure equipment:

- Operates as designed
- Operates efficiently
- Provides comfort
- Operates safely
- Is durable

5.3003.3b

Desired Outcome:

Air flow is properly tested

Specification(s):

External static pressure will be in accordance with manufacturer specifications

Objective(s):

Ensure equipment:

- Operates as designed
- Operates efficiently
- Provides comfort
- Operates safely
- Is durable

5.3003.3c

Desired Outcome:

Air flow is properly tested

Specification(s):

Pressure drop across cooling coils will be in accordance with manufacturer specifications

Objective(s):

Ensure equipment:

- Operates as designed
- Operates efficiently
- Provides comfort
- Operates safely
- Is durable

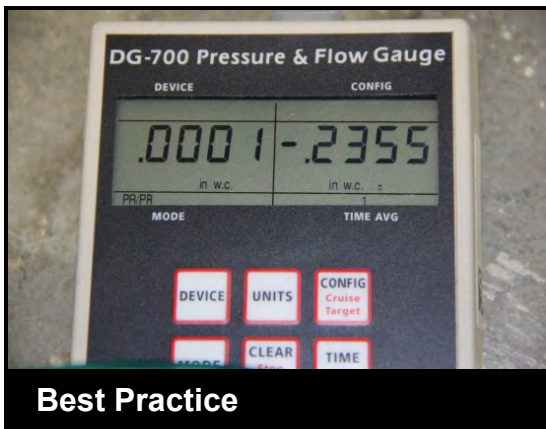

Best Practice

Pressure drop across the coil should be less than or equal to manufacturer recommendations, generally less than .3" w.c.

Tools:

1. manometer
2. static pressure probes
3. 1/4" hoses

5.3003.3c - Pressure



Drill holes being careful not to damage the evaporator coil.

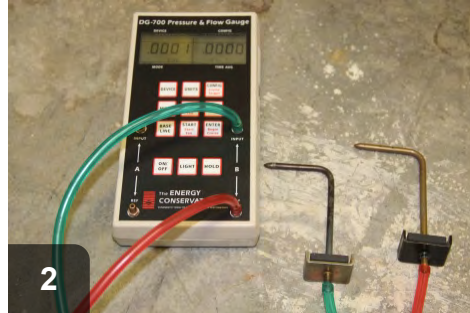

Hook gauges up to measure pressure before and pressure after the coil.



Static pressure probe should be inserted with the tip pointing into the air stream.



Probe placed before the coil.



Probe placed after the coil.



Measure resulting pressure drop of the dry evaporator coil.

5.3003.3d

Desired Outcome:

Air flow is properly tested

Specification(s):

Pressure drop across filter will be in accordance with manufacturer specifications

Objective(s):

Ensure equipment:

- Operates as designed
- Operates efficiently
- Provides comfort
- Operates safely
- Is durable

5.3003.3e

Desired Outcome:

Air flow is properly tested

Specification(s):

Air flow will be measured at each register to ensure proper air flow delivery

Objective(s):

Ensure equipment:

- Operates as designed
- Operates efficiently
- Provides comfort
- Operates safely
- Is durable

5.3003.3f

Desired Outcome:

Air flow is properly tested

Specification(s):

Supply wet bulb and dry bulb air temperatures will be recorded

Objective(s):

Ensure equipment:

- Operates as designed
- Operates efficiently
- Provides comfort
- Operates safely
- Is durable

5.3003.3g

Desired Outcome:

Air flow is properly tested

Specification(s):

Return wet bulb and dry bulb air temperatures will be recorded

Objective(s):

Ensure equipment:

- Operates as designed
- Operates efficiently
- Provides comfort
- Operates safely
- Is durable

5.3003.3h

Desired Outcome:

Air flow is properly tested

Specification(s):

Temperature rise between the supply and return will be in accordance with manufacturer specifications

Objective(s):

Ensure equipment:

- Operates as designed
- Operates efficiently
- Provides comfort
- Operates safely
- Is durable

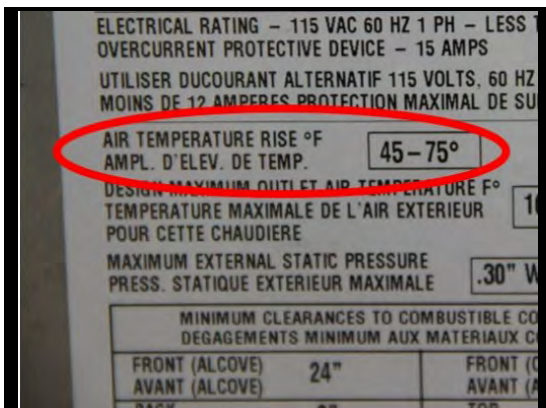

Best Practice

Temperature rise should be within the range specified by the manufacturer. If it is not, airflow must be adjusted.

Tools:

1. thermometers

Supply temperature(out of line of sight of the heat exchanger) - return temperature = air temperature rise

e.g. $116.8 - 88.5 = 28.3$ which is well outside of the manufacturers recommendations of 45-75. Air speed adjustment is needed.

5.3003.3h - Temperature rise: gas and oil furnaces only



1
Measure the temperature inside the combustion closet or the return nearest to the unit.



2
Return temperature is 88.5 degrees.



3
Measure the outgoing air temperature of the nearest supply register. Supply temperature is 116.8.

5.3003.5a

Desired Outcome:

Refrigerant lines properly installed

Specification(s):

All liquid refrigerant lines will be insulated to a minimum of R-4

Vapor or high side lines will not be insulated unless specified by the equipment's manufacturer

Suction lines will be insulated to a minimum of R-4

For mixed humid, hot humid, and marine climates, heating and cooling refrigerant lines will be insulated

Objective(s):

Ensure refrigerant lines do not gain excessive heat

Prevent energy loss and condensation



Best Practice

Refrigerant line set should be insulated to an R-4 to maintain performance

5.3003.5b

Desired Outcome:

Refrigerant lines properly installed

Specification(s):

If exposed to sunlight, refrigerant line insulation will be protected from UV degradation in accordance with manufacturer specifications, 2012 IRC N1103.3.1, or local code

Objective(s):

Install insulation so it does not degrade



Bad Practice

Line set insulation is exposed to direct sunlight and is severely degraded.



Best Practice

Line set insulation is protected with integrated UV protection. Tapes and other sealants may be required.

5.3003.5c

Desired Outcome:

Refrigerant lines properly installed

Specification(s):

Refrigerant lines will be sized to meet manufacturer specifications for the installed equipment

Objective(s):

Ensure system moves appropriate volume of refrigerant

5.3003.5d

Desired Outcome:

Refrigerant lines properly installed

Specification(s):

Refrigerant lines will be installed without kinks, crimps, or excessive bends

Objective(s):

Ensure system moves appropriate volume of refrigerant

5.3003.5e

Desired Outcome:

Refrigerant lines properly installed

Specification(s):

Refrigerant lines will be routed, supported, and secured to house in a manner that protects the line from damage by workers or occupants

Objective(s):

Ensure refrigerant lines do not move, vibrate, or sag

Protect lines from damage

5.3003.6a

Desired Outcome:

Sequence of operation of the system verified

Specification(s):

The sequence of operation of the system will be verified in accordance with the manufacturer installation, operation, and maintenance manual

Objective(s):

Ensure system components function and operate in the correct sequence

5.3003.7a

Desired Outcome:

Occupants understand their role and responsibility in the safe, effective, and efficient operation of the equipment

Specification(s):

Basic operation of the equipment will be explained to the occupant (e.g., design conditions, efficiency measures, differences from previous system or situation)

Objective(s):

Ensure occupant has a reasonable expectation of the equipment's capability

5.3003.7b

Desired Outcome:

Occupants understand their role and responsibility in the safe, effective, and efficient operation of the equipment

Specification(s):

Proper operation and programming of system controls to achieve temperature and humidity control will be explained to the occupant

Objective(s):

Ensure occupant can operate system controls

5.3003.7c

Desired Outcome:

Occupants understand their role and responsibility in the safe, effective, and efficient operation of the equipment

Specification(s):

Indoor and outdoor electrical disconnects and fuel shut-offs will be demonstrated to occupant

Objective(s):

Ensure occupant can shut off equipment in emergencies

5.3003.7d

Desired Outcome:

Occupants understand their role and responsibility in the safe, effective, and efficient operation of the equipment

Specification(s):

Location of combustion air inlets will be identified for occupant in accordance with NFPA 31, 54, and 58

Importance of not blocking inlets will be explained to occupant

Objective(s):

Ensure occupant does not block combustion air inlets

5.3003.7e

Desired Outcome:

Occupants understand their role and responsibility in the safe, effective, and efficient operation of the equipment

Specification(s):

Importance of cleaning dust and debris from return grilles will be explained to occupant

Proper placement of interior furnishings with respect to registers will be explained to occupant

Negative consequences of closing registers will be explained to occupant

Importance of leaving interior doors open as much as possible will be explained to occupant

Objective(s):

Ensure occupant does not prevent equipment from operating as designed

5.3003.7f

Desired Outcome:

Occupants understand their role and responsibility in the safe, effective, and efficient operation of the equipment

Specification(s):

Proper filter selection and how to change the filter will be explained to occupant

Importance of keeping outside unit clear of debris, vegetation, decks, and other blockage will be explained to occupant

Importance and timing of routine professional maintenance will be explained to occupant

Objective(s):

Ensure equipment operates as designed

5.3003.7g

Desired Outcome:

Occupants understand their role and responsibility in the safe, effective, and efficient operation of the equipment

Specification(s):

Situations when the occupant should contact the HVAC contractor will be explained, including:

- Fuel odors
- Water draining from secondary drain line
- Emergency heat indicator always on for a heat pump system
- System blowing cold air during heating season and vice versa
- Icing of the evaporator coil during cooling mode
- Outside unit never defrosts
- Unusual noises
- Unusual odors

Objective(s):

Notify occupant to contact installer when system is not operating as designed

5.3003.7h

Desired Outcome:

Occupants understand their role and responsibility in the safe, effective, and efficient operation of the equipment

Specification(s):

A carbon monoxide (CO) alarm will be installed

Objective(s):

Occupant will be made aware of operation of CO alarm



Carbon Monoxide alarms should be installed according to local codes

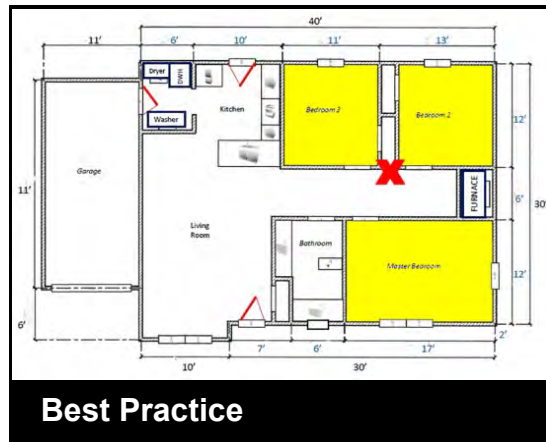

Alarms should be mounted near sleeping areas--such as the one marked in red

Tools:

1. Drill

Materials:

1. CO alarm
2. Fasteners

5.3003.7i

Desired Outcome:

Occupants understand their role and responsibility in the safe, effective, and efficient operation of the equipment

Specification(s):

Occupant will be provided with relevant manuals and warranties

The labor warranty will be explained and the occupant will be given a phone number to call for warranty service

Objective(s):

Provide manuals and warranties for future servicing

5.3003.11a

Desired Outcome:

Heating and cooling controls installed and set properly

Specification(s):

Mercury-based thermostat will be removed safely and disposed of in accordance with EPA regulations

Objective(s):

Protect workers and occupants from injury

Protect environment from damage



Mercury thermostats should be replaced and disposed of properly



Do NOT dispose of mercury thermostats in the trash--find local recycling

Paraphrased from 40 CFR 273.14: A universal waste mercury-containing thermostat or container containing only universal waste mercury-containing thermostats should be labeled or marked clearly with any of the following phrases: "Universal Waste-Mercury Thermostat(s)," "Waste Mercury Thermostat(s)," or "Used Mercury Thermostat(s)." **Contact thermostat-recycle.org or earth911.org for recycling options.

5.3003.11b

Desired Outcome:

Heating and cooling controls installed and set properly

Specification(s):

Existing controls will be removed in accordance with EPA lead safe work rules

Objective(s):

Protect workers and occupants from injury

Protect environment from damage

5.3003.11c

Desired Outcome:

Heating and cooling controls installed and set properly

Specification(s):

Penetrations for control wiring will be sealed with a durable sealant (e.g., caulk, silicone, foam) at both the interior (e.g., floor, sheetrock) and exterior air barriers (e.g., bottom liner, side walls)

Objective(s):

Ensure controls operate as designed

Minimize infiltration and exfiltration from house

5.3003.11d

Desired Outcome:

Heating and cooling controls installed and set properly

Specification(s):

Thermostats will be installed to reflect the temperature of the zone in which they are installed

Mounting location for air leakage and conductance that would affect the thermostat operation (e.g., marriage walls, exterior walls) will be accessed

Thermostats will not be exposed to extreme temperatures, radiant heat sources, and drafts

Objective(s):

Ensure controls operate as designed

5.3003.11e

Desired Outcome:

Heating and cooling controls installed and set properly

Specification(s):

Blower speed will be set for equipment in accordance with manufacturer specifications

Objective(s):

Ensure equipment has correct air flow

5.3003.11f

Desired Outcome:

Heating and cooling controls installed and set properly

Specification(s):

A thermostat with supplementary heat lockout that can interface with an outdoor temperature sensor will be selected

Objective(s):

Ensure supplementary heater operation is prevented when the heat pump is capable of meeting the load

5.3003.11g

Desired Outcome:

Heating and cooling controls installed and set properly

Specification(s):

Supplementary heat lockout on air-to-air heat pumps will be set to the economical balance point

ANSI/ACCA 3 Manual S-2004 Residential Equipment Selection will be referenced for set points when using different types of heat pumps

Objective(s):

Ensure supplementary heater operation is prevented when the heat pump is capable of meeting the load

5.3003.11h

Desired Outcome:

Heating and cooling controls installed and set properly

Specification(s):

For air-to-air heat pumps, low ambient compressor lockout will be set to 0°F outdoor temperature or ambient compressor lockout will be disabled

ANSI/ACCA 3 Manual S-2004 Residential Equipment Selection will be referenced for low ambient compressor lockout when using different types of heat pumps

Objective(s):

Ensure supplementary heater operation is prevented when the heat pump is capable of meeting the load

5.3003.11i

Desired Outcome:

Heating and cooling controls installed and set properly

Specification(s):

An outdoor temperature sensor will be installed in accordance with manufacturer specifications

Objective(s):

Ensure equipment operates as designed

5.3003.11j

Desired Outcome:

Heating and cooling controls installed and set properly

Specification(s):

Supplementary heat will be wired onto second stage heating terminal in accordance with manufacturer specifications

Objective(s):

Do not operate supplementary heat in stage one heating

5.3003.11k

Desired Outcome:

Heating and cooling controls installed and set properly

Specification(s):

The installer options will be set to match the thermostat to the equipment and control board settings

Objective(s):

Ensure equipment operates as designed

5.3003.11I

Desired Outcome:

Heating and cooling controls installed and set properly

Specification(s):

Time delay for equipment will be set in accordance with manufacturer specifications and as appropriate for the climate zone (e.g., no time delay for hot humid climates)

Objective(s):

Maximize transfer of heat without adversely affecting indoor humidity levels

5.3003.11m

Desired Outcome:

Heating and cooling controls installed and set properly

Specification(s):

Humidistat will be installed to reflect humidity of the zone in which it is installed

Humidistat will be installed in a dry location

Objective(s):

Ensure controls operate as designed

5.3003.11n

Desired Outcome:

Heating and cooling controls installed and set properly

Specification(s):

Ventilation controls will be connected to operational control system, as originally designed in the factory

Powered ventilation system alarm will be set to "on;" controls will be reset to factory settings

Objective(s):

Ensure proper operation of the mechanically dampered and powered ventilation systems

5.3003.11o

Desired Outcome:

Heating and cooling controls installed and set properly

Specification(s):

Occupants will be educated on proper use of thermostat, including:

- Proper use of setbacks for air conditioners and heat pumps
- Allowing occupant comfort to determine setback for combustion heating appliances
- Using emergency heat appropriately
- Educate property manager/occupant about fan on/auto or vent/auto operations
- Educate the property manager/occupant about ventilation, as it applies to controls
- Instruct the property manager/occupant to never leave the fan set to "on" or "vent" in humid climates
- Educate property manager/occupant about possible moisture problems when thermostat is set low for extended periods of time during the summer

Objective(s):

Ensure equipment and controls operate as designed

Provide comfort throughout house

Ensure property manager/occupant knows how to operate the system

Minimize moisture problems

5.3003.12a

Desired Outcome:

Maximize efficiency and performance of existing system, when required by the authority having jurisdiction

Specification(s):

Assessment will be performed to identify problems with air, refrigerant, electrical, load, safety, indoor environmental quality (IEQ), and/or other needed repairs

If new installation or replacement is necessary, ACCA Manual J, Manual S, and/or Manual D will be referenced to determine if the existing duct system is adequate for the sizing of the furnace, and the procedures outlined in ANSI/ACCA 5 QI-2010 HVAC Quality Installation Specification will be followed

Objective(s):

Determine the scope of repair, service, and level of expertise required to perform the work

5.3003.12b

Desired Outcome:

Maximize efficiency and performance of existing system, when required by the authority having jurisdiction

Specification(s):

Nonsalvageable components and waste will be removed and disposed of properly

Refrigerant will be removed in accordance with EPA requirements

Objective(s):

Prepare for installation of new equipment or components

Ensure environmental and legal compliance

5.3003.12c

Desired Outcome:

Maximize efficiency and performance of existing system, when required by the authority having jurisdiction

Specification(s):

Repairs will be performed by qualified specialist as identified in the assessment

Maintenance will be done in accordance with ANSI/ACCA 4

Maintenance of Residential HVAC Systems-2007 and ANSI/ACCA 6 HVAC

System Cleanliness-2007

Objective(s):

Optimize performance of the system

5.3003.12d

Desired Outcome:

Maximize efficiency and performance of existing system, when required by the authority having jurisdiction

Specification(s):

Service will be performed by qualified personnel as identified in the assessment

Maintenance will be done in accordance with ANSI/ACCA 4

Maintenance of Residential HVAC Systems-2007 and ANSI/ACCA 6 HVAC

System Cleanliness-2007

Objective(s):

Optimize performance of the system

5.3003.12e

Desired Outcome:

Maximize efficiency and performance of existing system, when required by the authority having jurisdiction

Specification(s):

Equipment will be fully tested for proper operation following procedures outlined in ANSI/ACCA 5 QI-2010

Property manager/occupant will be educated on how to operate and maintain system, including thermostat operation and system changes

Objective(s):

Ensure proper system operation

Ensure property manager/occupant is educated

5.3003.13a

Desired Outcome:

Properly charged system

Specification(s):

Leak detection, air flow, and refrigerant line inspection will be checked and repaired to determine need for refrigerant charge

Objective(s):

Eliminate possible sources of other problems before addressing refrigerant charging

5.3003.13b

Desired Outcome:

Properly charged system

Specification(s):

Charge will be tested and work performed by a qualified contractor

Refrigerant charge will be in accordance with ANSI/ACCA 5 QI-2010 HVAC Quality Installation Specification refrigerant charging requirements for mixed humid, hot humid, marine, and hot dry climates

Objective(s):

Ensure compliance with codes and environmental regulations

Ensure proper equipment charge

5.3003.13c

Desired Outcome:

Properly charged system

Specification(s):

Contractor will provide documentation of work performed

Objective(s):

Maintain record of work performed

5.3003.13d

Desired Outcome:

Properly charged system

Specification(s):

External static pressure will be measured and documented

EPA refrigerant charge log will be provided

Objective(s):

Ensure external static pressure is within range in accordance with manufacturer specifications

Ensure quality workmanship

5.3003.14a

Desired Outcome:

Analysis of critical components and operations completed in accordance with industry and manufacturer specifications

Specification(s):

Heating equipment will be placed in operation in accordance with applicable NFPA standards and manufacturer specifications when available

Objective(s):

Ensure equipment:

- Operates as designed
- Operates safely
- Operates efficiently
- Is durable

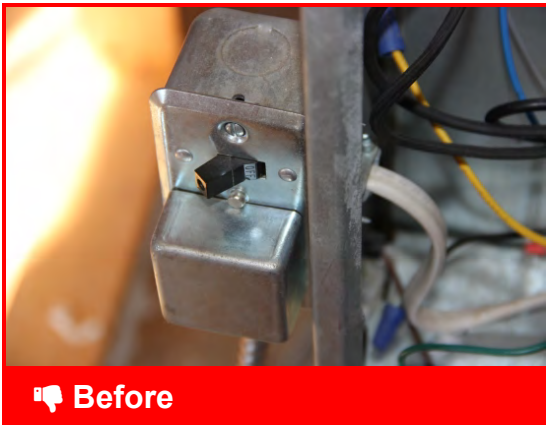

Appliance is set to OFF at the electrical disconnect, and will not fire.



Appliance is set to ON at the disconnect, and can now fire.

Ensure appliance is fired in accordance with manufacturer specifications.

5.3003.14a - Place appliance in operation



1 Propane - Ensure gas valve is open at the tank and there is fuel in the tank.



2 Natural Gas - Ensure the valve on the meter is on.



3 Ensure gas valve is open at the appliance.

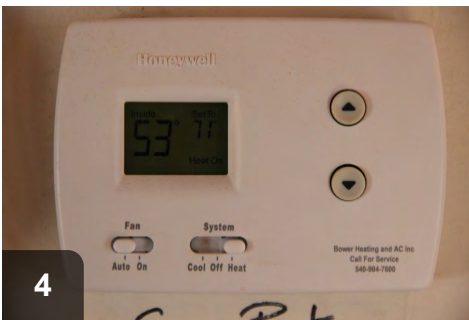

4 Turn appliance to heat, and raise the the temperature 15 degrees above ambient conditions.

5.3003.14b

Desired Outcome:

Analysis of critical components and operations completed in accordance with industry and manufacturer specifications

Specification(s):

Measurement will be verified by a certified professional in accordance with fuel type and manufacturer specifications

Objective(s):

Ensure equipment:

- Operates as designed
- Operates safely
- Operates efficiently
- Is durable



Best Practice

Natural gas should have a manifold pressure of 3.5" w.c.



Best Practice

Propane should have a manifold pressure of 10" w.c.

Tools:

1. Gas pressure gauge

5.3003.14b - Gas pressure

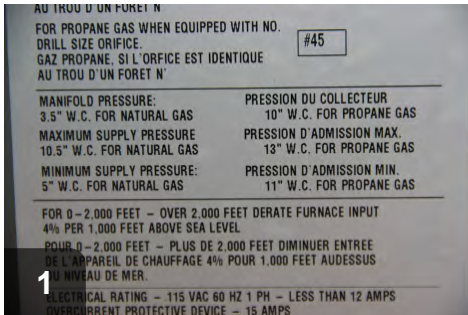

See the manufacturer specifications for desired manifold pressure.

5.3003.14c

Desired Outcome:

Analysis of critical components and operations completed in accordance with industry and manufacturer specifications

Specification(s):

Measurement will be verified in accordance with industry manuals (e.g., Testo, Bacharach)

Objective(s):

Ensure equipment:

- Operates as designed
- Operates safely
- Operates efficiently
- Is durable



Best Practice

Carbon dioxide and oxygen levels should be measured in undiluted flue gas

Tools:

1. Combustion analyzer with probe

Oxygen levels should usually fall between 7 - 9%. CO₂ should be between 6.5 - 8%.

5.3003.14d

Desired Outcome:

Analysis of critical components and operations completed in accordance with industry and manufacturer specifications

Specification(s):

Excess combustion air will be calculated and verified in accordance with industry manuals (e.g., Testo, Bacharach)

Objective(s):

Ensure equipment:

- Operates as designed
- Operates safely
- Operates efficiently
- Is durable



Best Practice

Excess combustion air should be measured in undiluted flue gas

Excess air or EA should be within manufacturer levels, generally between 35 - 50%.

5.3003.14e

Desired Outcome:

Analysis of critical components and operations completed in accordance with industry and manufacturer specifications

Specification(s):

CO in the undiluted flue gas will be less than 100 ppm

Objective(s):

Ensure equipment:

- Operates as designed
- Operates safely
- Operates efficiently
- Is durable

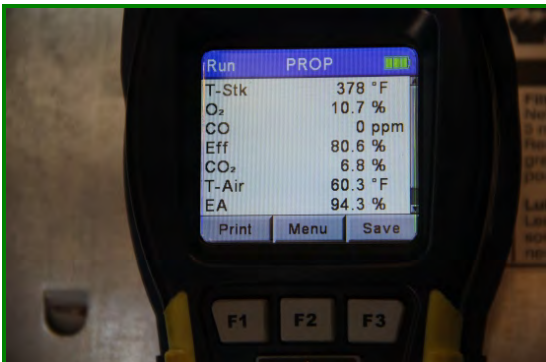

Best Practice

CO levels should be less than 100 ppm to ensure safe operation

5.3003.14e - Carbon monoxide (CO) in flue gas



Direct vent appliances have concentric venting. The inner liner exhausts flue gas and the outer draws in combustion air



Ensure that the test ports drilled penetrate into the flue. Be sure to drop the outer liner into position before testing



With the test ports lined up on the inner and outer pipe, measurements can be taken in undiluted flue gas.

5.3003.14f

Desired Outcome:

Analysis of critical components and operations completed in accordance with industry and manufacturer specifications

Specification(s):

All testing and inspection holes will be sealed with manufacturer approved materials

Objective(s):

Ensure equipment:

- Operates as designed
- Operates safely
- Operates efficiently
- Is durable



The testing hole was left unsealed.



The hole in both walls has been properly sealed with a plug, cap, or other approved method.

Materials:

1. high temperature sealant
2. stainless steel plug or cap
3. stainless 5/16" bolt

5.3003.14f - Testing/inspection holes



Apply high temperature sealant to the bolt, so that both holes will be sealed.



Screw the bolt into place, ensuring a proper seal on both pipes.



If sealing each wall individually, insert the plug into each hole.



Apply high temperature sealant to the perimeter of the plug.

5.3003.15a

Desired Outcome:

Analysis of critical components and operations completed to industry and manufacturer specifications

Specification(s):

Smoke test will be conducted before any combustion testing is completed

Smoke spot reading will be in accordance with burner manufacturer specifications

Objective(s):

Ensure equipment:

- Operates as designed
- Operates safely
- Operates efficiently
- Is durable



Best Practice

Verify oil-fired furnaces and water heaters are operating safely



Best Practice

Smoke tests determine if oil-fired appliances burn cleanly by testing soot

Tools:

1. Smoke testing pump

Materials:

1. Filter paper

5.3003.15a - Oil system: smoke test



Place filter paper in testing pump and draw air through paper



Remove paper and verify draw was successful by checking for soot



Compare level of soot deposit against smoke chart. A rating of 0 is ideal



Appliances with ratings of 3 or higher should be cleaned and tuned

5.3003.15b

Desired Outcome:

Analysis of critical components and operations completed to industry and manufacturer specifications

Specification(s):

Nozzle size, angle, and spray pattern will be correct for design input and within equipment firing rate of the heating system manufacturer

Objective(s):

Ensure equipment:

- Operates as designed
- Operates safely
- Operates efficiently
- Is durable



Best Practice

Locate nozzles on oil-fired water heaters and furnaces

Nozzle Rating at 100 PSI	Nozzle Flow Rates In Gallons Per Hour (Approx.)					
	120 PSI	140 PSI	160 PSI	175 PSI	200 PSI	300 PSI
0.40	0.44	0.47	0.51	0.53	0.57	0.69
0.50	0.55	0.59	0.63	0.66	0.71	0.87
0.60	0.66	0.71	0.76	0.79	0.85	1.04
0.65	0.71	0.77	0.82	0.86	0.92	1.13
0.75	0.82	0.89	0.95	0.99	1.06	1.30
0.85	0.93	1.01	1.08	1.12	1.20	1.47
0.90	0.99	1.10	1.14	1.19	1.27	1.56
1.00	1.10	1.20	1.26	1.32	1.41	1.73
1.00	1.31	1.42	1.48	1.56	1.65	1.91
1.20	1.48	1.60	1.71	1.79	1.91	2.34
1.50	1.64	1.77	1.90	1.98	2.12	2.60
1.65	1.81	1.95	2.09	2.18	2.33	2.86
1.75	1.92	2.07	2.21	2.32	2.47	3.03
2.00	2.19	2.37	2.53	2.65	2.83	3.46
2.25	2.46	2.66	2.85	2.98	3.18	3.90
2.50	2.74	2.96	3.16	3.31	3.54	4.33
2.75	3.01	3.25	3.48	3.64	3.89	4.76
3.00	3.29	3.55	3.79	3.97	4.24	5.20

After

Verify that nozzle size is appropriate for model by consulting flow chart

Tools:

1. Calipers

5.3003.15c

Desired Outcome:

Analysis of critical components and operations completed to industry and manufacturer specifications

Specification(s):

Filter will be present, clean, and leak free

Objective(s):

Ensure equipment:

- Operates as designed
- Operates safely
- Operates efficiently
- Is durable



Best Practice

Filter is present, clean, and shows no signs of leakage

5.3003.15d

Desired Outcome:

Analysis of critical components and operations completed to industry and manufacturer specifications

Specification(s):

Measurement will be verified in accordance with manufacturer specifications

Objective(s):

Ensure equipment:

- Operates as designed
- Operates safely
- Operates efficiently
- Is durable



Best Practice

Check oil-fired furnaces and water heaters for proper fuel pressure

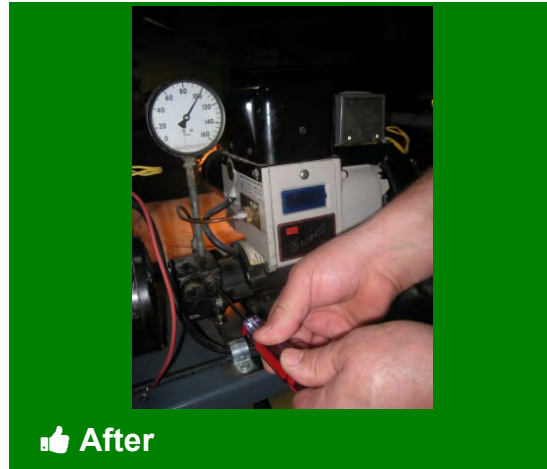

After

Verify that fuel pressure matches manufacturer's specifications

5.3003.15e

Desired Outcome:

Analysis of critical components and operations completed to industry and manufacturer specifications

Specification(s):

Measurement will be verified in accordance with manufacturer specifications

Objective(s):

Ensure equipment:

- Operates as designed
- Operates safely
- Operates efficiently
- Is durable

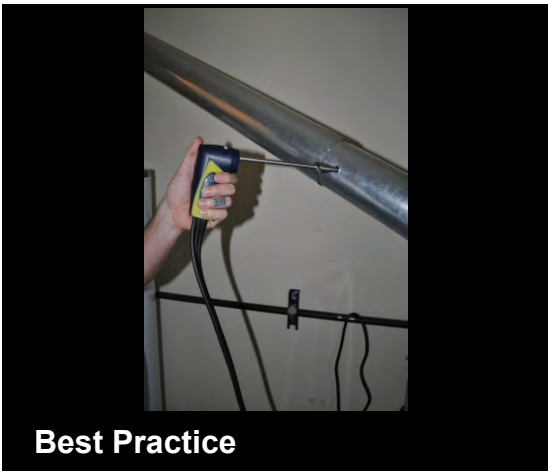

Best Practice

Test flue gases to determine steady state efficiency



Best Practice

At steady state, this furnace tests at 83%-- within manufacturer tolerances

Tools:

1. Combustion analyzer with probe

5.3003.15f

Desired Outcome:

Analysis of critical components and operations completed to industry and manufacturer specifications

Specification(s):

Net stack temperature will be measured and verified in accordance with manufacturer specifications

Objective(s):

Ensure equipment:

- Operates as designed
- Operates safely
- Operates efficiently
- Is durable

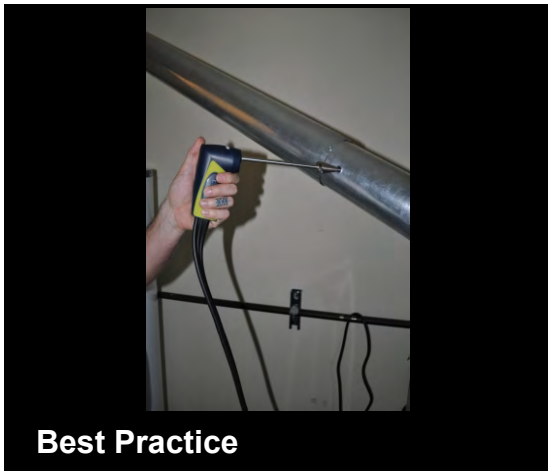

Best Practice

Verify oil-fired appliances are not burning hotter than manufacturer specs



After

T-stack minus T-air equals net stack temperature. Check against specs

Tools:

1. Combustion analyzer with probe

T=temperature. T-stack minus T-air = Delta T or Net Stack Temperature.

5.3003.15g

Desired Outcome:

Analysis of critical components and operations completed to industry and manufacturer specifications

Specification(s):

Measurement will be verified in accordance with industry manuals (e.g., Testo, Bacharach)

Objective(s):

Ensure equipment:

- Operates as designed
- Operates safely
- Operates efficiently
- Is durable

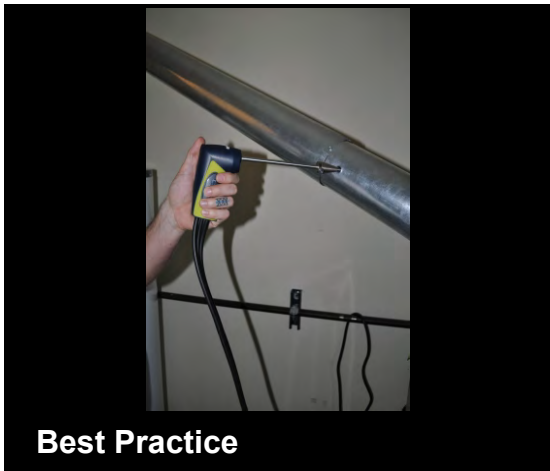

Best Practice

Verify oil-fired appliances are burning safely by testing CO₂ and O₂ levels



After

Levels should be within industry standards and match manufacturer specs

Tools:

1. Combustion analyzer with probe
2. Drill

15.4% should be the highest allowable level of CO₂ produced by an oil-fired appliance.

O₂ levels in the atmosphere are at a constant 20.9%. O₂ readings in appliances vary due to O₂ density and the efficiency of the combustion process.

5.3003.15h

Desired Outcome:

Analysis of critical components and operations completed to industry and manufacturer specifications

Specification(s):

Excess combustion air will be calculated and shown to be in accordance with industry manuals (e.g., Testo, Bacharach)

Objective(s):

Ensure equipment:

- Operates as designed
- Operates safely
- Operates efficiently
- Is durable

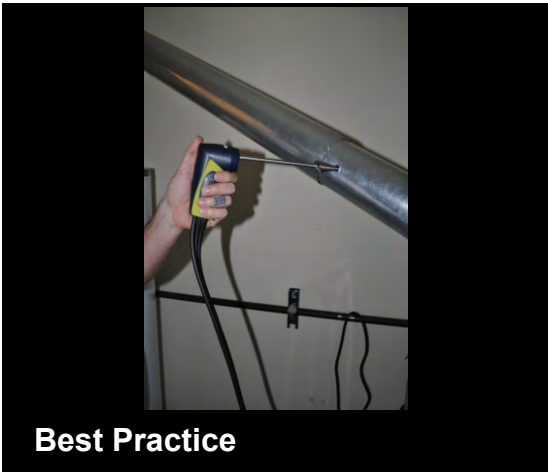

Best Practice

Oil-fired appliances require an appropriate level of air mixed with the oil



After

The percentage of Excess Air (EA) should be within manufacturer specs

Tools:

1. Combustion analyzer with probe
2. Drill

5.3003.15i

Desired Outcome:

Analysis of critical components and operations completed to industry and manufacturer specifications

Specification(s):

CO in the undiluted flue gas will be less than 100 ppm

Objective(s):

Ensure equipment:

- Operates as designed
- Operates safely
- Operates efficiently
- Is durable

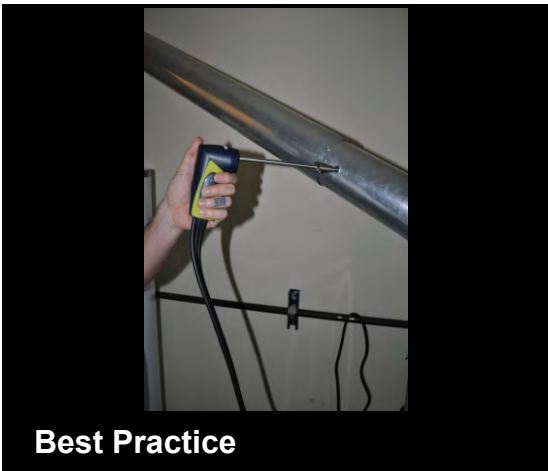

Best Practice

Test oil-fired appliances for CO in the flue gases to verify safe levels



After

CO should measure less than 100ppm

Tools:

1. Combustion analyzer with probe
2. Drill

5.3003.15j

Desired Outcome:

Analysis of critical components and operations completed to industry and manufacturer specifications

Specification(s):

All testing and inspection holes will be sealed with approved materials

Objective(s):

Ensure equipment:

- Operates as designed
- Operates safely
- Operates efficiently
- Is durable



The testing hole was left unsealed.



The hole in both walls has been properly sealed with a plug, cap, or other approved method.

5.3003.15j - Testing/inspection holes



If using a bolt, apply high temperature sealant to the bolt, so that both holes will be sealed.



Screw the bolt into place, ensuring a proper seal on both pipes.



If sealing each wall individually, insert the plug into each hole.



Apply high temperature sealant to the perimeter of the plug.

5.3003.16a

Desired Outcome:

Electrical components properly tested

Specification(s):

Homes will have a four-wire service entrance to the panel box to ensure a wiring system that is nominally rated at 120/240 volts and allows for proper grounding

Grounding at the service entrance will be checked to determine proper grounding of the home

Objective(s):

Ensure occupant and worker safety

5.3003.16b

Desired Outcome:

Electrical components properly tested

Specification(s):

Polarity of equipment will be verified by a qualified technician if wiring is to be modified or repaired

Objective(s):

Ensure equipment:

- Operates as designed
- Operates safely

5.3003.16c

Desired Outcome:

Electrical components properly tested

Specification(s):

Voltage will be in accordance with manufacturer specifications

Objective(s):

Ensure equipment operates as designed

5.3003.16d

Desired Outcome:

Electrical components properly tested

Specification(s):

Voltage drop will be within acceptable range in accordance with manufacturer specifications

Objective(s):

Ensure contactor does not overheat

Ensure equipment operates as designed

5.3003.16e

Desired Outcome:

Electrical components properly tested

Specification(s):

Grounding will be connected in compliance with local code requirements, ANSI/NEMA GR 1-2007, and NFPA 70 National Electric Code

Frames of home sections will be bonded with copper wire

Bonding lug will be selected to prevent corrosion due to dissimilar metals

Objective(s):

Ensure equipment:

- Operates as designed
- Operates safely

Ensure ground continuity among sections

5.3003.16f

Desired Outcome:

Electrical components properly tested

Specification(s):

Amperage will not exceed manufacturer full load amperage

Objective(s):

Ensure equipment:

- Operates as designed
- Operates efficiently
- Operates safely

5.3003.16g

Desired Outcome:

Electrical components properly tested

Specification(s):

Amperage will not exceed manufacturer full load amperage

Objective(s):

Ensure equipment:

- Operates as designed
- Operates efficiently
- Operates safely

5.3003.16h

Desired Outcome:

Electrical components properly tested

Specification(s):

Blower compartment safety switch operation will be verified, if present

Objective(s):

Ensure blower:

- Does not operate during service
- Cannot backdraft a flue when the door is off

5.3003.16i

Desired Outcome:

Electrical components properly tested

Specification(s):

Emergency heat circuit functions will be verified

Objective(s):

Ensure system delivers heat in case of compressor failure

5.3202.1a

Desired Outcome:

Reduce solar heat gain for manufactured homes

Specification(s):

Existing roof coating will be assessed for hazardous material

Objective(s):

Ensure worker and occupant safety

5.3202.1b

Desired Outcome:

Reduce solar heat gain for manufactured homes

Specification(s):

Roof will be stripped of all debris, algae, and peeled and loose coating

Repairs to roof and penetrations will be made before application

Objective(s):

Ensure roof is clean, dry, and structurally sound for proper adhesion of new coating

5.3202.1c

Desired Outcome:

Reduce solar heat gain for manufactured homes

Specification(s):

Material will be approved for application to metal and existing roof coating

Material will be an ENERGY STAR qualified reflective coating

Roof coating will be durable, flexible, reflective, and meet ASTM D412, ASTM D1737, and UL 790 Class A

Objective(s):

Provide proper reflective coating

5.3202.1d

Desired Outcome:

Reduce solar heat gain for manufactured homes

Specification(s):

Roof-coating material will be applied in accordance with manufacturer specifications

Objective(s):

Ensure proper application

5.3202.1e

Desired Outcome:

Reduce solar heat gain for manufactured homes

Specification(s):

Occupant will be educated on the maintenance of reflective coating per manufacturer specifications, including annual inspection and cleaning

Objective(s):

Preserve integrity and effectiveness of reflective coating

6.6002.3a

Desired Outcome:

Exhaust grille location optimizes either primary or local ventilation

Specification(s):

Fan intake grille will be installed in a central location within the main body of the house

Ensure it is accessible for filter change and cleaning

Objective(s):

Provide whole house air exchange

6.6002.3b

Desired Outcome:

Exhaust grille location optimizes either primary or local ventilation

Specification(s):

Fan intake grille will be installed in the space where odor, moisture vapor, or other contaminants are generated

Objective(s):

Remove contaminated air at the source

6.6002.4a

Desired Outcome:

Installed ducts effectively move the required volume of air and prevent condensation

Specification(s):

Consideration will be given to:

- Vent termination location
- Amount of space for duct run
- Roof condition, type, and access (e.g., metal, shingle, bow string, flat)
- Duct insulation

When applicable, pitch duct to remove condensation to outdoors

Ducts will be as straight as possible, fully extended, and have the shortest run possible

Turns will be made so the radius at the centerline is no less than one duct diameter

Duct diameter will be equal to or greater than the exhaust fan outlet

Fan flow will be verified by flow measurement to meet ASHRAE Standard 62.2

Objective(s):

Effectively move the required volume of air

6.6002.4b

Desired Outcome:

Installed ducts effectively move the required volume of air and prevent condensation

Specification(s):

Ducts installed outside of the thermal envelope will be insulated to a minimum of R-8 or in accordance with local codes

Objective(s):

Prevent condensation from forming or collecting inside or outside of the ductwork



Before

Existing flex duct that does not meet the requirement of R-8.0 should be removed



After

All new and replacement ducting in unconditioned spaces should be R-8.0 minimum

6.6002.4c

Desired Outcome:

Installed ducts effectively move the required volume of air and prevent condensation

Specification(s):

Horizontal runs will be supported in accordance with flex duct manufacturer specifications and local codes

Supports with a width of at least 1 ½" will be used or adequate metal support

Objective(s):

Effectively move the required volume of air

Preserve the integrity of the duct system



Straps should be at least 1.5" wide.



Straps should be spaced in accordance with manufacturers specification, typically 4ft.

Materials:

1. 1.5" webbing or strap material

6.6002.4d

Desired Outcome:

Installed ducts effectively move the required volume of air and prevent condensation

Specification(s):

Metal-to-metal or metal-to-PVC connections will be fastened with a minimum of three equally spaced screws

Flexible duct-to-metal or flexible duct-to-PVC connections will be fastened with tie bands using a tie band tensioning tool

PVC-to-PVC connections will be fastened with approved PVC cement

Other specialized duct fittings will be fastened in accordance with manufacturer specifications

In addition to mechanical fasteners, duct connections will be sealed with UL 181B or 181B-M listed material

Objective(s):

Effectively move the required volume of air

Preserve the integrity of the duct system



For flex to metal connections, use zip tie and tensioner to secure liner to connection fitting.

Tools:

1. drill
2. tie band tensioner

Materials:

1. mechanical fastener
2. tie bands
3. PVC primer and cement

6.6002.4d - Duct connections



Round metal-to-metal connections require fiberglass mesh tape and 3 mechanical fasteners minimum.



PVC-to-PVC connections should use PVC primer and cement.

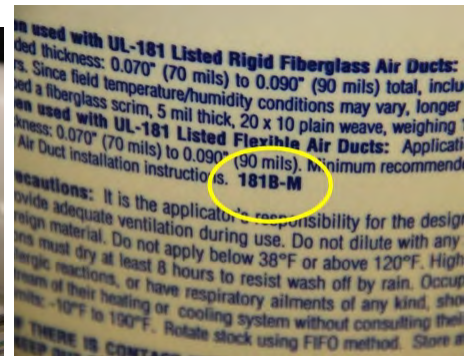

Sealants should show UL181-M or UL181B-M.

6.6002.4e

Desired Outcome:

Installed ducts effectively move the required volume of air and prevent condensation

Specification(s):

Flexible materials will be UL 181 listed or Air Diffusion Council approved

Rigid, smooth metal of 30-gauge wall thickness or thicker will be used

PVC material may be used

Objective(s):

Effectively move the required volume of air

Preserve the integrity of the duct system

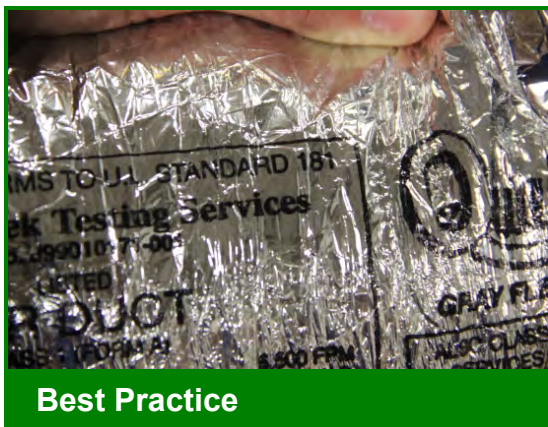

Best Practice

This material conforms to UL Standard 181.

6.6002.4e - Duct materials



Look for the Air Diffusion Council seal.

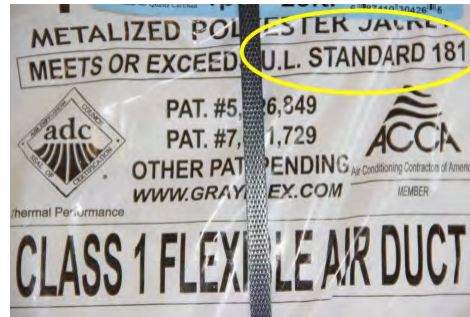

Flex installed should meet or exceed UL181.

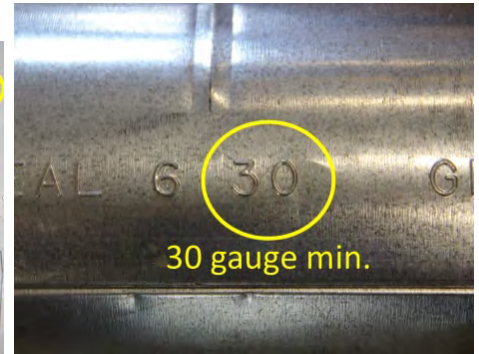

When rigid duct is being used, its wall thickness should be 30 gauge minimum.

6.6002.4f

Desired Outcome:

Installed ducts effectively move the required volume of air and prevent condensation

Specification(s):

Total exhaust system ventilation airflow will be measured

Objective(s):

Ensure air flow is as designed



Best Practice

Exhaust fan flow should be measured and compared with the fans rated capacity as well as ASHRAE 62.2 requirements.

Tools:

1. Exhaust fan flow meter
2. Manometer

ASHRAE requires the following flows for bath fans: 50CFM intermittent, or 20CFM continuous.

The requirements for kitchen range hoods are: 100CFM intermittent, or 5ACH(for kitchen area) continuous.

6.6003.1a

Desired Outcome:

Surface-mounted ducted fans installed to specification

Specification(s):

A hole no greater than a 1/4" greater than the assembly will be cut to accommodate fan assembly

Objective(s):

Minimize repair work

Ensure a secure installation



In Progress

Determine size to cut hole by measuring fan assembly and ducting



After

A snug fit should be ensured to minimize weatherproofing required

Tools:

1. Tape measure
2. Saw
3. Writing utensil

6.6003.1a - Hole through interior surface



Measure the termination fitting to determine proper hole diameter (in this case, 4")



Hole should be no more than 1/4" larger than assembly diameter



Clear wall surface and mark hole size 1/4" larger than termination fitting



Since opening is larger than most hole saws, precision cutting is important

6.6003.1b

Desired Outcome:

Surface-mounted ducted fans installed to specification

Specification(s):

Wiring will be installed by a properly licensed contractor, as required by the authority having jurisdiction

Wiring will be installed in accordance with original equipment manufacturer specifications, and local and national electrical and mechanical codes

Objective(s):

Prevent an electrical hazard

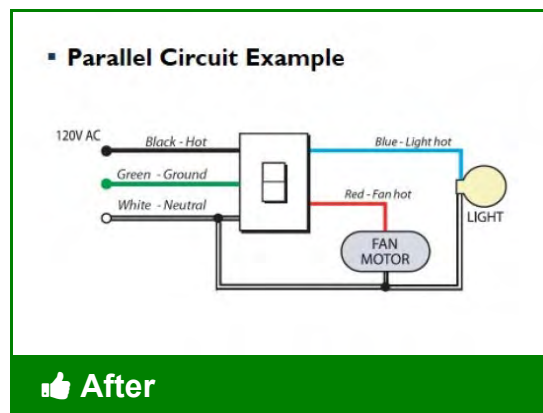
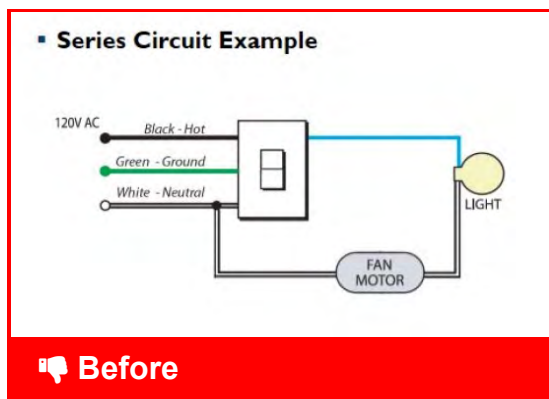

6.6003.1c

Desired Outcome:

Surface-mounted ducted fans installed to specification

Specification(s):

Fan outlet will be oriented toward the final termination location

Fan will be oriented so the equivalent length of the duct run is as short as possible

Fan will be mounted securely in accordance with manufacturer specifications

Objective(s):

Ensure short duct run to achieve optimum air flow

Ensure a secure installation

Ensure fan housing does not shake, rattle, or hum when operating



Bad Practice



Best Practice

6.6003.1d

Desired Outcome:

Surface-mounted ducted fans installed to specification

Specification(s):

A backdraft damper will be installed between the outlet side of the fan and the exterior

Objective(s):

Prevent reverse air flow when the fan is off

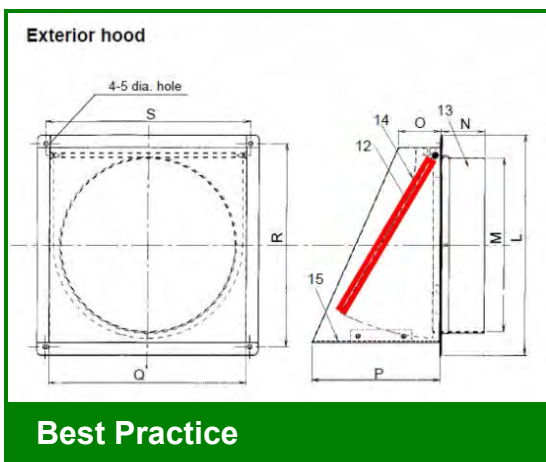

Damper should be installed to maintain exterior air barrier

6.6003.1e

Desired Outcome:

Surface-mounted ducted fans installed to specification

Specification(s):

Duct-to-fan outlet will be connected and sealed as follows:

- Round metal-to-metal or metal-to-PVC connections will be fastened with a minimum of three equally spaced screws
- Other metal-to-metal or metal-to-PVC connections will be securely fastened and sealed with welds, gaskets, mastics (adhesives), mastic-plus-embedded-fabric systems, or tapes
- Flexible duct-to-metal or flexible duct-to-PVC connections will be fastened with tie bands using a tie band tensioning tool
- PVC-to-PVC connections will be fastened with approved PVC cement
- Other specialized duct fittings will be fastened according to manufacturer specifications
- In addition to mechanical fasteners, duct connections will be sealed with UL 181B or 181B-M listed material

Objective(s):

Exhaust to outside



The connection has been sealed with mastic, and is being secured with 3 mechanical fasteners minimum.

Tools:

1. drill
2. tie band tensioner
3. brush

Materials:

1. tie bands
2. mechanical fasteners
3. UL181 listed mastic
4. PVC primer and cement

6.6003.1e - Duct-to-fan connection



Round metal-to-metal connections require fiberglass mesh tape and 3 mechanical fasteners minimum.



PVC-to-PVC connections should use PVC primer and cement.

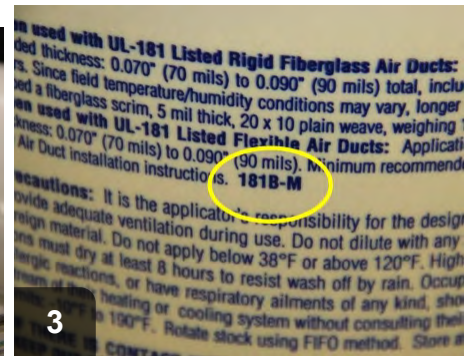

Sealants should show UL181-M or UL181B-M.

6.6003.1f

Desired Outcome:

Surface-mounted ducted fans installed to specification

Specification(s):

Gaps and holes in fan housing will be sealed with caulk or other sealants in accordance with manufacturer recommendations

Sealants will be compatible with their intended surfaces

Sealants will be continuous and meet fire barrier specifications

Objective(s):

Prevent air leakage through fan housing

Ensure a permanent seal

Prevent a fire hazard



Best Practice

Seal openings in the fan housing to ensure that air is exhausted only from the desired location.

Tools:

1. caulk gun

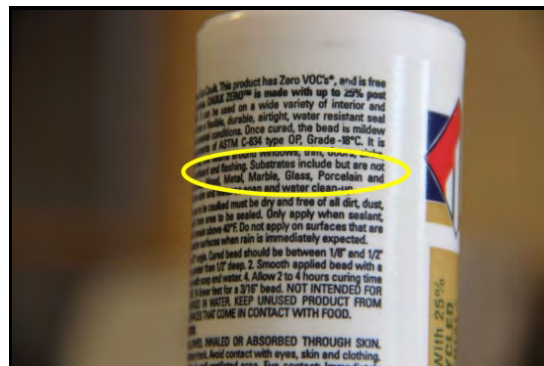

Best Practice

Sealant should be approved for its intended surfaces.

Materials:

1. caulk

6.6003.1g

Desired Outcome:

Surface-mounted ducted fans installed to specification

Specification(s):

Sealants will be compatible with their intended surfaces

Sealants will be continuous and meet fire barrier specifications

Objective(s):

Prevent air leakage between house and fan



The opening for the fan is unsealed, allowing air leakage into or out of the attic.



The fan to interior surface seal is made using the proper materials and prevents airflow to and from the attic space.

6.6003.1h

Desired Outcome:

Surface-mounted ducted fans installed to specification

Specification(s):

Air flows in cubic feet per minute (CFM) will be measured and adjusted to meet the whole house upgrade design requirements

Objective(s):

Exhaust sufficient air from desired locations to outside



In Progress

Exhaust fan flow should be measured and compared with the fans rated capacity as well as ASHRAE 62.2 requirements.

Tools:

1. digital manometer
2. exhaust fan flow measuring device
3. fan speed controller

6.6003.1h - Air flow

Simulation Input (Before)		
CFM50 / N-Value		
3200	41.8	76.5
Continuous Ventilation to (Needed - Credit)		30.0
		cfm

1 Perform the ASHRAE calculation to determine the Qfan or continuous ventilation needed.

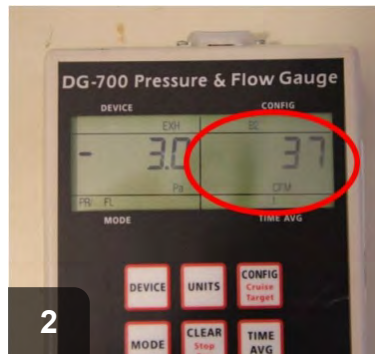

2 Measure the fan flow to see how much adjustment is needed.



3 Adjust the fan speed using the chosen fan control device.

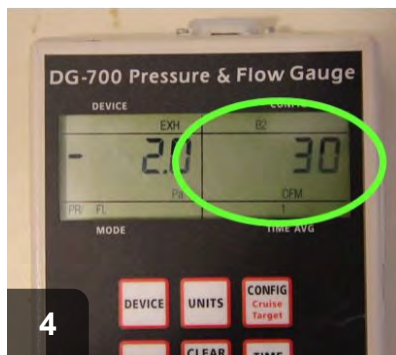

4 Re-measure the fan flow, and continue making adjustments until desired flow is achieved.

6.6003.1i

Desired Outcome:

Surface-mounted ducted fans installed to specification

Specification(s):

Leakage to the house from other spaces will be prevented (e.g., garages, unconditioned crawl spaces, unconditioned attics)

Objective(s):

Ensure occupant health and safety

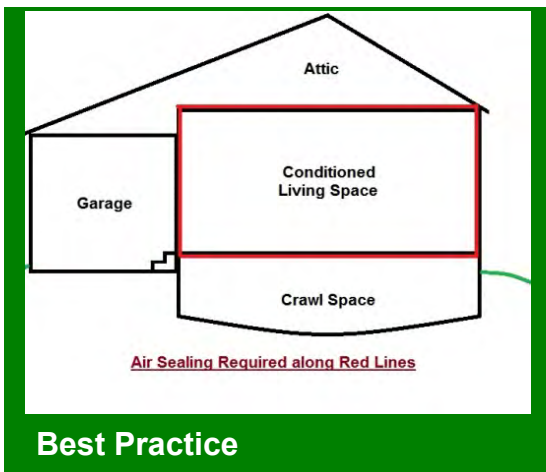

The barrier between conditioned and unconditioned spaces should be sealed

6.6003.1j

Desired Outcome:

Surface-mounted ducted fans installed to specification

Specification(s):

Pressure effects will be assessed and corrected on all combustion appliances

Objective(s):

Ensure safe operation of combustion appliances



Before

Installing new ventilation can cause imbalances within the house



Test that depressurization limit is not being exceeded by new ventilation

Tools:

1. Manometer

See SWS 2.0299.1a-i for CAZ depressurization limits

6.6003.1j - Combustion safety



1 Run depressurization testing on house to ensure new ventilation isn't causing unsafe conditions



2 If depressurization limit is exceeded, mitigate to eliminate safety risk

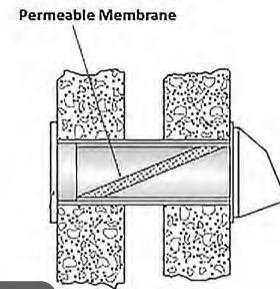

3 Mitigate safety risk with make-up air or other pressure relief



4 After mitigation, verify that depressurization limits are not being exceeded

6.6003.2a

Desired Outcome:

Inline fans installed to specification

Specification(s):

Wiring will be installed by a properly licensed contractor, as required by the authority having jurisdiction

Wiring will be installed in accordance with original equipment manufacturer specifications, and local and national electrical and mechanical codes

Objective(s):

Prevent an electrical hazard

6.6003.2b

Desired Outcome:

Inline fans installed to specification

Specification(s):

Fan and service switch will be accessible for maintenance according to NFPA 70 National Electric Code or local authority having jurisdiction

Objective(s):

Fan and service switch will be accessible for maintenance

6.6003.2c

Desired Outcome:

Inline fans installed to specification

Specification(s):

Fan outlet will be oriented toward the final termination location

Fan will be oriented so the equivalent length of the duct run is as short as possible

Fan will be mounted securely in accordance with manufacturer specifications

Fan will be isolated from the building framing unless specifically designed to be directly attached

Fan will be installed remotely by installing ducting from intake grille

Objective(s):

Ensure short duct run to achieve optimum air flow

Ensure fan is installed securely

Ensure fan housing or building framing does not shake, rattle, or hum when operating

Minimize noise

6.6003.2d

Desired Outcome:

Inline fans installed to specification

Specification(s):

A backdraft damper will be installed between the outlet side of the fan and the exterior

Objective(s):

Prevent reverse air flow when the fan is off

6.6003.2e

Desired Outcome:

Inline fans installed to specification

Specification(s):

Ducts will be connected and sealed to the intake fan and termination fitting as follows:

- Round metal-to-metal or metal-to-PVC connections will be fastened with a minimum of three equally spaced screws
- Other metal-to-metal or metal-to-PVC connections will be securely fastened and sealed with welds, gaskets, mastics (adhesives), mastic-plus-embedded-fabric systems or tapes
- Flexible duct-to-metal or flexible duct-to-PVC connections will be fastened with tie bands using a tie band tensioning tool
- PVC-to-PVC connections will be fastened with approved PVC cement
- Other specialized duct fittings will be fastened in accordance with manufacturer specifications
- In addition to mechanical fasteners, duct connections will be sealed with UL 181B or 181B-M listed material

Objective(s):

Exhaust from desired location to outside

Preserve integrity of the duct system and building envelope

6.6003.2f

Desired Outcome:

Inline fans installed to specification

Specification(s):

Sealants will be compatible with their intended surfaces

Sealants will be continuous and meet fire barrier specifications

Objective(s):

Prevent air leakage around intake housing

Prevent a fire hazard

6.6003.2g

Desired Outcome:

Inline fans installed to specification

Specification(s):

Air flows in CFM will be measured and adjusted to meet the design requirements

Objective(s):

Exhaust sufficient air from desired locations to outside



In Progress

Exhaust fan flow should be measured and compared with the fans rated capacity as well as ASHRAE 62.2 requirements.

Tools:

1. digital manometer
2. exhaust fan flow measuring device
3. fan speed controller

6.6003.2g - Air flow

Simulation Credit (Before)		
CFM50 / N-Value		
3200	41.8	76.5
Continuous Ventilation to (Needed - Credit)		30.0
		cfm

1 Perform the ASHRAE calculation to determine the Qfan or continuous ventilation needed.

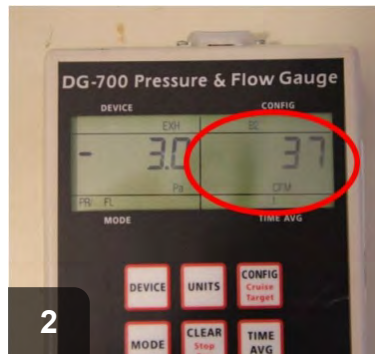

2 Measure the fan flow to see how much adjustment is needed.



3 Adjust the fan speed using the chosen fan control device.

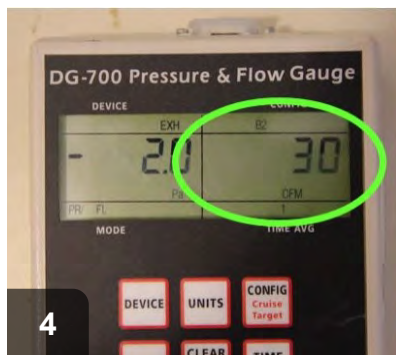

4 Re-measure the fan flow, and continue making adjustments until desired flow is achieved.

6.6003.2h

Desired Outcome:

Inline fans installed to specification

Specification(s):

Leakage to the house from other spaces will be prevented (e.g., garages, unconditioned crawl spaces, unconditioned attics)

Objective(s):

Ensure occupant health and safety

6.6003.2i

Desired Outcome:

Inline fans installed to specification

Specification(s):

Pressure effects caused by fans will be assessed and corrected when found outside of combustion safety standards

Exhaust fans and other exhausting systems shall be provided with makeup air or other pressure relief

Objective(s):

Ensure safe operation of combustion appliances



Pressure should be measured in the CAZ to verify combustion appliances operate safely.



If depressurization in the CAZ exceeds acceptable limits, return air pathways or make up air may be needed.

Tools:

1. digital manometer
2. static pressure probe
3. 1/4" hoses
4. smoke stick or equivalent
5. combustion analyzer

6.6003.2i - Combustion safety

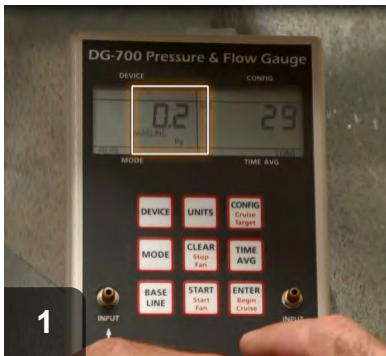

1 Set the house to natural conditions. With the manometer measuring CAZ WRT outside, perform the baseline procedure.



2 Turn on all exhausting appliances(vented outdoors), including the dryer, kitchen fan, and bath fans.



3 Close all doors. With your back to the CAZ, smoke doors with fans behind them. Smoke in:open door, smoke out:close it.

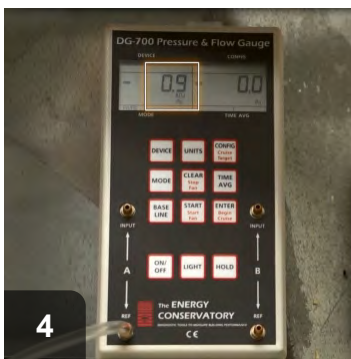

4 Measure CAZ pressure with the door open and record the reading. Close the door and record the reading.



5 Turn on the air handler fan.

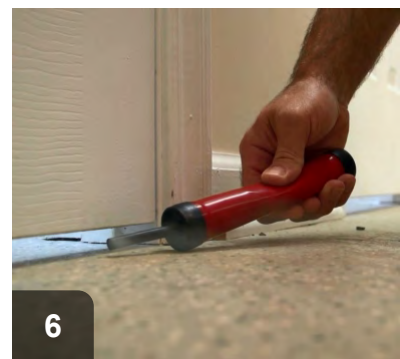

6 Recheck all door positions for worst case depressurization. Smoke hits your toes, leave the door closed.

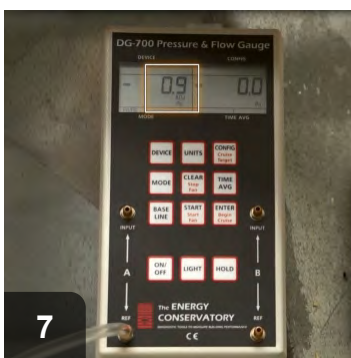

7 Measure CAZ pressure with the door open then closed. Record the readings. Recreate the WCD, or the most negative seen.



8 Fire the unit and check draft pressure using the manometer or combustion analyzer.



9 Measure flue gases at steady state and record readings. Turn off the unit being tested per manufacturers instructions.

6.6003.5a

Desired Outcome:

Contaminants properly removed from house

Specification(s):

Ventilation for garage will be exhaust only and provide a minimum installed capacity of 100 CFM of ventilation per vehicle bay and will vent directly outdoors

Garage exhaust fan will be wired for continuous operation or installed with automatic controls that activate the fan whenever the garage is occupied and for at least 15 minutes after the garage has been vacated

If a ducted fan (not through-the-wall) is used, measure and verify the minimum air flow and adjust as necessary

Objective(s):

Remove contaminants from garage

Reduce contaminant migration from garage to house

Ensure occupant health and safety

6.6003.5b

Desired Outcome:

Contaminants properly removed from house

Specification(s):

Air leakage between the house and garages will be prevented by sealing and weatherstripping

Objective(s):

Ensure occupant health and safety

Reduce conditioned air being drawn from the house

Reduce contaminant migration from garage to house



Before

The reading is zero indicating strong connection with the garage.



After

The reading is closer to 50, indicating the garage is connected to the outside.

Tools:

1. blower door assembly
2. manometer

6.6003.5b - Air leakage



Depressurize the house to 50 pascals.



The reading of 50 pascals indicates the zone is more closely connected to the outside.

6.6003.5c

Desired Outcome:

Contaminants properly removed from house

Specification(s):

Pressure effects caused by fans will be assessed and corrected when found outside of combustion safety standards

Exhaust fans and other exhausting systems shall be provided with makeup air or other pressure relief

Objective(s):

Ensure safe operation of combustion appliances

Ensure occupant health and safety



Pressure should be measured in the CAZ to verify combustion appliances operate safely.



If depressurization in the CAZ exceeds acceptable limits, return air pathways or make up air may be needed.

Tools:

1. Manometer
2. Static pressure probe
3. 1/4" hoses
4. Smoke pencil
5. Combustion analyzer

6.6003.5c - Combustion safety

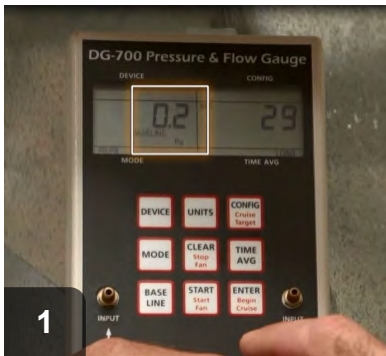

1 Set the house to natural conditions. With the manometer measuring CAZ WRT outside, perform the baseline procedure.

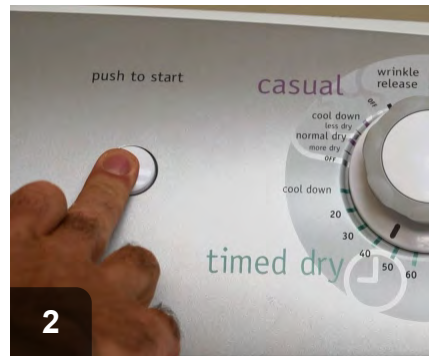

2 Turn on all exhausting appliances(vented outdoors), including the dryer, kitchen fan, and bath fans.



3 Close all doors. With your back to the CAZ, smoke doors with fans behind them. Smoke in:open door, smoke out:close it.

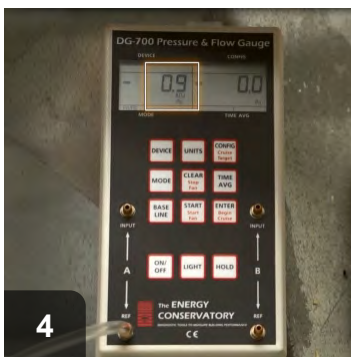

4 Measure CAZ pressure with the door open and record the reading. Close the door and record the reading



5 Turn on the air handler fan

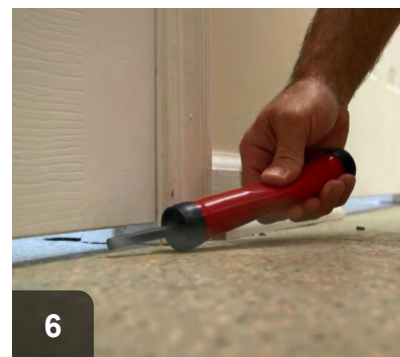

6 Recheck all door positions for worst case depressurization. Smoke hits your toes, leave the door closed.

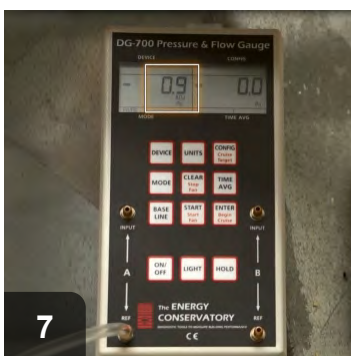

7 Measure CAZ pressure with the door open then closed. Record the readings. Recreate the WCD, or the most negative seen.

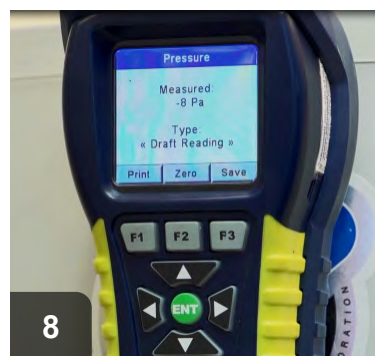

8 Fire the unit and check draft pressure using the manometer or combustion analyzer



9 Measure flue gases at steady state and record readings. Turn off the unit being tested per manufacturers instructions.

6.6003.6a

Desired Outcome:

Provide primary ventilation for common spaces

Specification(s):

Clearance for size of the fan recommended will be determined

Consideration will be given for adequate head clearance

Objective(s):

Ensure access for installation, operation, and maintenance

Ensure occupant safety

6.6003.6b

Desired Outcome:

Provide primary ventilation for common spaces

Specification(s):

Power source load will be determined as adequate

Consideration will be given to power source location

Objective(s):

Provide accessible and adequate power source

6.6003.6c

Desired Outcome:

Provide primary ventilation for common spaces

Specification(s):

No resistance greater than 3 pascals will exist between fan intake location with reference to the common area

Objective(s):

Allow fresh air distribution to common areas

6.6003.6d

Desired Outcome:

Provide primary ventilation for common spaces

Specification(s):

Consideration will be given to:

- Vent termination location
- Amount of space for duct run
- Roof condition and type (e.g., metal, shingle, bow string, flat)
- Duct insulation

When applicable, pitch duct to remove condensation to outdoors

Ducts will be as straight as possible, fully extended, and have the shortest run possible

To the extent possible, turns will be made so that the radius at the centerline is no less than one duct diameter

Duct diameter will be equal to or greater than the exhaust fan outlet

Fan flow will be verified by flow measurement to meet ASHRAE standard 62.2

Objective(s):

Effectively move the required volume of air

6.6003.6e

Desired Outcome:

Provide primary ventilation for common spaces

Specification(s):

Fan will be secured to a structural component

Structural integrity of the manufactured home will be maintained (e.g., roof trusses, walls, floor joists)

Objective(s):

Maintain structural integrity

Maintain fan attachment

6.6003.6f

Desired Outcome:

Provide primary ventilation for common spaces

Specification(s):

Total exhaust system airflow will be measured

Objective(s):

Ensure exhaust airflow is as designed



Measure the fan flow with the flow meter.

Tools:

1. Exhaust fan flow meter
2. Manometer

ASHRAE requires the following flows for bath fans: 50CFM intermittent, or 20CFM continuous.

The requirements for kitchen range hoods are: 100CFM intermittent, or 5ACH(for kitchen area) continuous.

6.6003.6f - Total exhaust airflow



1 Attach hose to the fan meter.



2 Attach hose to the manometer set to PR/PR.



3 Adjust gate on the flow meter as needed.

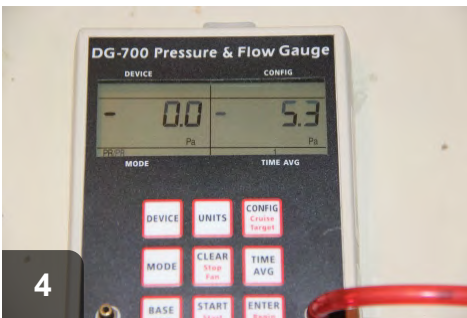

4 With the flow meter in place, read the resulting pressure on the manometer.

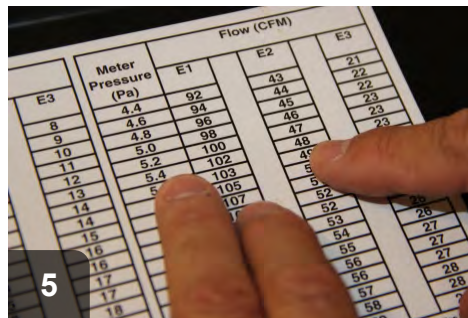

5 Match the pressure reading to the gate selection and read the final CFM flow.

6.6005.1a

Desired Outcome:

Dryer air exhausted efficiently and safely

Specification(s):

Clothes dryers will be ducted to the outdoors, which does not include unconditioned spaces, such as attics and crawl spaces that are ventilated with the outdoors

As short a run as practical of rigid sheet metal or semi-rigid sheet metal venting material will be used in accordance with manufacturer specifications

Dryer ducts exceeding 35' in duct equivalent length will have a dryer booster fan installed

Plastic venting material will not be used

Uninsulated clothes dryer duct will not pass through unconditioned spaces, such as attics and crawl spaces

Ducts will be connected and sealed as follows:

- UL-listed foil type or semi-rigid sheet metal to rigid metal will be fastened with clamp
- Other specialized duct fittings will be fastened in accordance with manufacturer specifications
- In addition to mechanical fasteners, duct connections will be sealed with UL 181B or 181B-M listed material

In addition,

- Sheet metal screws or other fasteners that will obstruct the exhaust flow will not be used
- Condensing dryers will be plumbed to a drain

Objective(s):

Preserve integrity of building envelope

Effectively move air from clothes dryer to outside



Before

Dryer is vented outside, but with wrong material



After

Dryer is vented outdoors, with correct material. Run is as short and straight as possible ensuring maximum flow.

Tools:

1. Metal snips
2. Drill

Materials:

1. Metal flex duct
2. Dryer vent kit
3. Hose clamps

6.6005.1a - Clothes dryer ducting



1 Disconnect existing vent pipe from termination. If hose clamp is installed, save for reuse.



2 Disconnect existing vent pipe from dryer.



3 Attach approved vent material to termination vent. Termination vent may need to be trimmed.



4 Trim metal vent to ensure the run is as short and straight as possible.



5 Connect vent pipe to dryer.



6 Dryer vents to outdoors, and exhaust damper is functional.



7 For vent runs >35 feet, a booster fan is required.

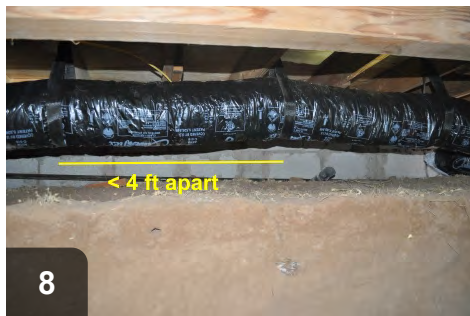

8 Duct runs outside of conditioned space must be insulated and properly supported.

6.6005.1b

Desired Outcome:

Dryer air exhausted efficiently and safely

Specification(s):

Termination fitting manufactured for use with dryers will be installed

A backdraft damper will be included, as described in termination fitting detail

Objective(s):

Preserve integrity of building envelope

Effectively move air from clothes dryer to outside



Termination fittings for dryers should have backdraft dampers

6.6005.1b - Termination fitting



Most modern dryer vents have a built-in backdraft damper



To minimize pest intrusion, mesh >1/4" square can be used

6.6005.1c

Desired Outcome:

Dryer air exhausted efficiently and safely

Specification(s):

Makeup air will be provided for appliances exhausting more than 200 CFM

Objective(s):

Preserve integrity of building envelope

Effectively move air from clothes dryer to outside

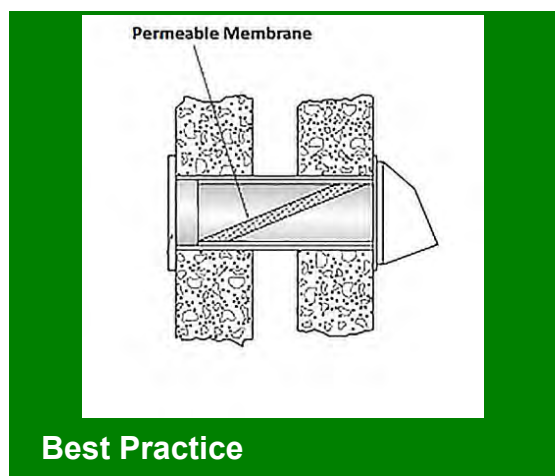

A passive inlet vent can provide make-up air for dryer exhaust

Tools:

1. Drill
2. Hole saw
3. Caulk gun

Materials:

1. Caulk sealant
2. Fasteners

6.6005.1d

Desired Outcome:

Dryer air exhausted efficiently and safely

Specification(s):

Pressure effects caused by fans will be assessed and corrected when found outside of combustion safety standards

Objective(s):

Ensure safe operation of combustion appliances

Ensure occupant health and safety



Appliance exhaust, such as that for a dryer, can cause depressurization



Test to verify combustion appliances are within depressurization limits

Tools:

1. Manometer

See SWS 2.0299.1a-i for CAZ depressurization limits

6.6005.1d - Combustion safety



1 Run depressurization testing on house to ensure new ventilation isn't causing unsafe conditions



2 If depressurization limit is exceeded, mitigate to eliminate safety risk

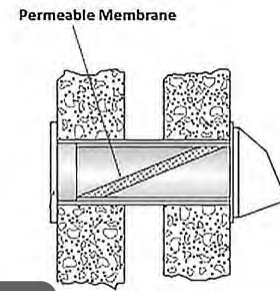

3 Install make-up air, such as a passive inlet vent, or other pressure relief



4 After mitigation, verify that depressurization limit is not being exceeded

6.6005.1e

Desired Outcome:

Dryer air exhausted efficiently and safely

Specification(s):

Occupant will be instructed to keep lint filter and termination fitting clean

Occupant will be instructed to keep dryer booster fan clean, if present

Occupant will be instructed on clothes dryer operation safety, including information on items that must not be placed in the clothes dryer (items with any oil or other flammable liquid on it, foam, rubber, plastic or other heat-sensitive fabric, glass fiber materials)

Objective(s):

Effectively move air from clothes dryer to outside



Unsafe

Neglect of clothes dryer maintenance can cause fire hazards



Best Practice

Occupants should be taught to clean lint filters and termination fittings

6.6005.1e - Occupant education



In homes with booster fans, occupant should know location and how to clean



Occupants should be taught never to put flammable articles in dryer (in this case, oily rags)

6.6005.2a

Desired Outcome:

Kitchen range fan installed to specification

Specification(s):

Wiring will be installed in accordance with local regulations or the 2012 IRC in the absence of such regulations or where those regulations are not as stringent as the 2012 IRC

Wiring will be installed in accordance with original equipment manufacturer specifications, and local and national electrical and mechanical codes

Wiring will be installed by a licensed electrician

Objective(s):

Prevent an electrical hazard

6.6005.2b

Desired Outcome:

Kitchen range fan installed to specification

Specification(s):

Kitchen range fans will be vented to the outdoors

Recirculating fans will not be used as a ventilating device

Objective(s):

Remove cooking contaminants from the house

Preserve integrity of building envelope

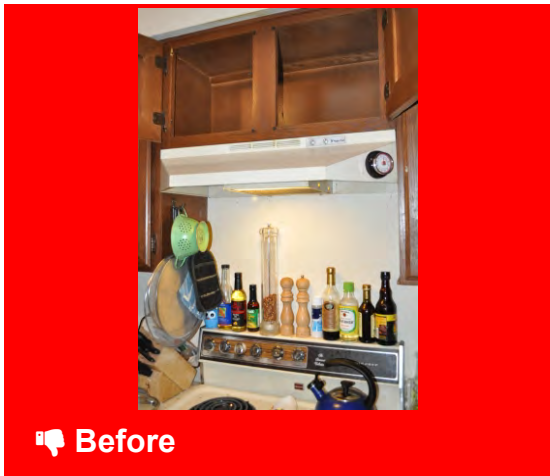

Recirculating fans over ranges do not actually remove contaminants



Daylight visible through dampered kitchen exhaust proves venting access

6.6005.2c

Desired Outcome:

Kitchen range fan installed to specification

Specification(s):

Kitchen range fans will be ducted to the outdoors

As short a run as practical of smooth wall metal duct will be used, following manufacturer specifications

Ducting will be connected and sealed as follows:

- Metal-to-metal connections will be fastened with a minimum of three equally spaced screws
- Other metal-to-metal connections will be securely fastened and sealed with welds, gaskets, mastics (adhesives), mastic-plus-embedded-fabric systems, or tapes
- For down-draft exhaust systems, PVC-to-PVC connections will be fastened with approved PVC cement
- Other specialized duct fittings will be fastened in accordance with manufacturer specifications
- In addition to mechanical fasteners, duct connections will be sealed with UL 181B or 181B-M listed material

Objective(s):

Preserve integrity of building envelope

Effectively move air from range to outside



 Before

Exhaust duct should be smooth-walled and in as short a run as possible



 After

Daylight visible through dampered kitchen exhaust proves outside access

Tools:

1. Drill
2. Metal snips
3. Saw
4. Putty knife
5. Tape measure
6. Disposable brushes
7. Wire cutters
8. Scissors

Materials:

1. Round metal ducting
2. Mastic
3. Fiberglass mesh tape
4. Fasteners
5. Galvanized wire to secure insulation onto ductwork
6. Nylon webbing for hanging ducts
7. UL-181 foil or Mylar tape to seal seams in insulation vapor barrier

See also 6.6002.4d. Note: Only smooth-wall metal duct will be used, except for down-draft exhaust systems where PVC is acceptable as well. Flex duct is NOT acceptable for kitchen fan exhaust application.

From the Manufactured Housing SWS: Ducts installed outside of the thermal [envelope](#) will be insulated to a minimum of R-8 or in accordance with local codes.

6.6005.2c - Fan ducting



1
Duct run should be as smooth and short as possible

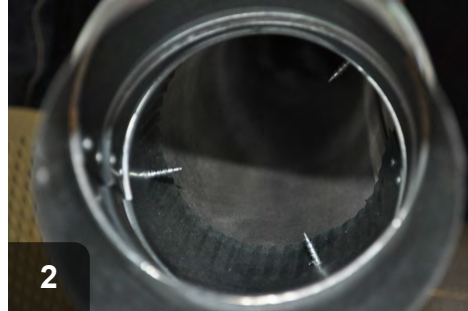

2
Duct should be fastened securely with three evenly-spaced screws



3
Then joints should be secured with fiberglass tape



4
Coat joint with UL-181 mastic, at least 0.08" (2mm) thick



5
Wrap duct with R-8 insulation. Seal seams in insulation vapor barrier with UL-181 listed foil or Mylar tape

6.6005.2d

Desired Outcome:

Kitchen range fan installed to specification

Specification(s):

Termination fitting will be installed including a backdraft damper, as described in termination fitting detail

Objective(s):

Ensure safe operation of combustion appliances

Ensure occupant health and safety



Kitchen exhaust termination fitting should include a backdraft damper

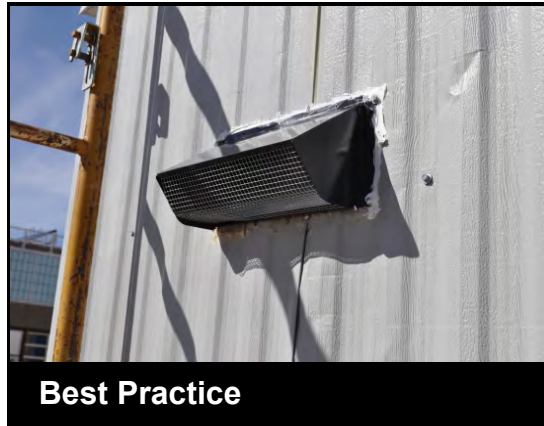

A screen can also help to discourage vermin infiltration

6.6005.2e

Desired Outcome:

Kitchen range fan installed to specification

Specification(s):

Makeup air will be provided for kitchen range fans exhausting more than 200 CFM

Objective(s):

Ensure safe operation of combustion appliances

Ensure occupant health and safety



If kitchen exhaust is venting at more than 200 cfm, provide make-up air

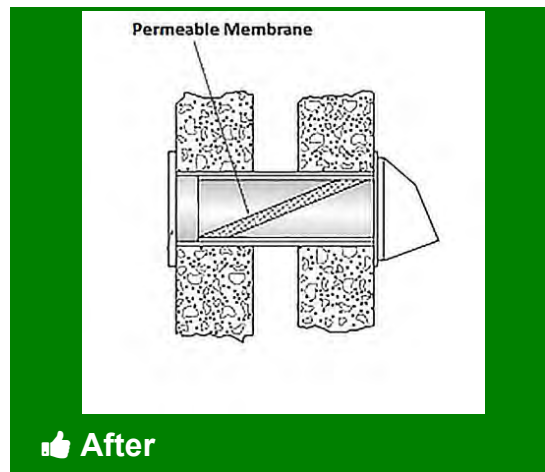

A passive inlet vent can provide make-up air for kitchen exhaust

Tools:

1. Drill
2. Hole saw
3. Caulk gun

Materials:

1. Caulk sealant
2. Fasteners

6.6005.2f

Desired Outcome:

Kitchen range fan installed to specification

Specification(s):

Pressure effects caused by fans will be assessed and corrected when found outside of combustion safety standards

Objective(s):

Ensure safe operation of combustion appliances

Ensure occupant health and safety



Kitchen exhaust fans can cause combustion appliances to depressurize



Test that combustion appliances are operating within depressurization limit

Tools:

1. Manometer

See SWS 2.0299.1a-i for CAZ depressurization limits

6.6005.2f - Combustion safety



1 Run depressurization testing on house to ensure new ventilation isn't causing unsafe conditions



2 If appliances exceed depressurization limit, mitigate to reduce risk

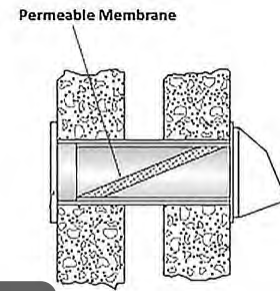

3 Install a source of make-up air, such as a passive inlet vent



4 After mitigation, verify that depressurization limits are not being exceeded

6.6005.2g

Desired Outcome:

Kitchen range fan installed to specification

Specification(s):

Occupant will be instructed to keep grease filters and termination fitting clean

Objective(s):

Effectively move air from kitchen range to outdoors

6.6102.4a

Desired Outcome:

Intake reduces pollutant entry, is easily maintained, has proper flow, and enhances house durability

Specification(s):

Existing forced air system leakage to the outside will be less than 10% of the air handler flow when measured at 25 pascals with reference to the outside

Any portion of the return located inside the Combustion Appliance Zone will be air sealed

Objective(s):

Reduce migration of pollutants

6.6102.4b

Desired Outcome:

Intake reduces pollutant entry, is easily maintained, has proper flow, and enhances house durability

Specification(s):

Wiring will be installed by a properly licensed contractor, as required by the authority having jurisdiction

Wiring will be installed in accordance with original equipment manufacturer specifications, and local and national electrical and mechanical codes

Objective(s):

Prevent an electrical hazard

6.6102.4c

Desired Outcome:

Intake reduces pollutant entry, is easily maintained, has proper flow, and enhances house durability

Specification(s):

Motorized damper and service switch will be accessible for maintenance in accordance with required code or authority having jurisdiction

Objective(s):

Ensure accessibility for maintenance

6.6102.4d

Desired Outcome:

Intake reduces pollutant entry, is easily maintained, has proper flow, and enhances house durability

Specification(s):

Ventilation duct will be attached as close to the HVAC system's fan as possible while remaining in compliance with HVAC manufacturer specifications

Filtration of ventilation air will be provided before reaching the thermal conditioning components

Filtration will be accessible and serviceable

Duct will be connected to intake fitting

Connection and seal will be performed in accordance with supply duct detail

Objective(s):

Ensure short duct run to achieve optimum air flow

Preserve integrity of the duct system and building envelope

6.6102.4e

Desired Outcome:

Intake reduces pollutant entry, is easily maintained, has proper flow, and enhances house durability

Specification(s):

A motorized damper or equivalent technology will be installed between the intake fitting and the return side of the air handler

Air flow will be provided by sequenced operation of the damper or equivalent technology

Objective(s):

Prevent air flow when none is desired

6.6102.4f

Desired Outcome:

Intake reduces pollutant entry, is easily maintained, has proper flow, and enhances house durability

Specification(s):

An accessible filter will be installed

Filter will be able to remove contaminants consistent with at least minimum efficiency reporting value (MERV) 6 or better when tested in accordance with ANSI/ASHRAE 52.2-2007

Filter or air cleaning systems that intentionally produce ozone will not be allowed

Objective(s):

Ensure occupant health and safety

Preserve integrity of the building envelope

6.6102.4g

Desired Outcome:

Intake reduces pollutant entry, is easily maintained, has proper flow, and enhances house durability

Specification(s):

Occupant will be educated on how and when to change filter

Objective(s):

Ensure occupant health and safety

Preserve integrity of the building envelope

6.6102.4h

Desired Outcome:

Intake reduces pollutant entry, is easily maintained, has proper flow, and enhances house durability

Specification(s):

Total intake ventilation airflow will be measured

Objective(s):

Ensure airflow is as designed

6.6188.2a

Desired Outcome:

Safe removal of garage supply vents

Specification(s):

Supply run feeding the register will be truncated as near to the supply plenum as possible

If directly connected to the plenum, the supply run will be truncated at the plenum

If connected to a Y or T branch system, the supply run will be truncated at the Y or T

Return grille located in garage will be removed in the same manner as supply

Objective(s):

Minimize duct leakage

6.6188.2b

Desired Outcome:

Safe removal of garage supply vents

Specification(s):

All holes in sheet metal ducts will be patched with sheet metal and secured with sufficient screws to hold the patch flat without gaps

Holes left in any Y or T will be capped with sheet metal caps and fastened with at least three screws

Objective(s):

Ensure a secure and strong patch

6.6188.2c

Desired Outcome:

Safe removal of garage supply vents

Specification(s):

All patches will be sealed with mastic meeting UL 181 and in accordance with manufacturer specifications

Objective(s):

Ensure an airtight patch

6.6188.2d

Desired Outcome:

Safe removal of garage supply vents

Specification(s):

All abandoned ductwork will be removed from work area

Objective(s):

Provide a clean work site

6.6188.2e

Desired Outcome:

Safe removal of garage supply vents

Specification(s):

Holes created by the removal of the register and boot will be patched and taped using material meeting local codes

Objective(s):

Prevent a fire hazard

6.6188.2f

Desired Outcome:

Safe removal of garage supply vents

Specification(s):

Units will be tested for external static pressure (ESP) before and after work

If there is a significant rise in ESP, air flow testing will be required

Objective(s):

Ensure correct fan performance

6.6188.2g

Desired Outcome:

Safe removal of garage supply vents

Specification(s):

CAZ testing will be performed where combustion appliances are utilized

Objective(s):

Identify possible conditions that can cause unsafe equipment operating conditions

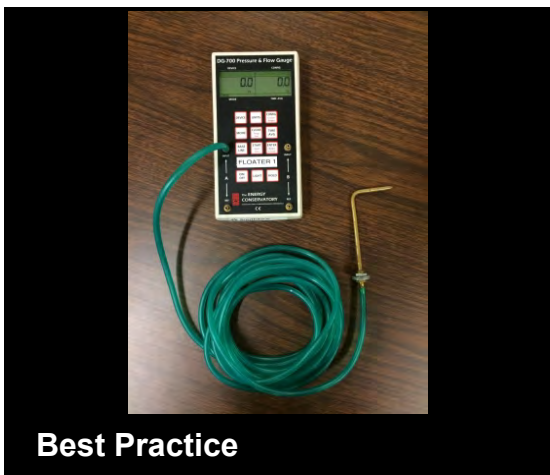

Complete combustion appliance zone testing to ensure a healthy, safe environment

**See
SWS 2.0201.3a-
2.0201.3h
for CAZ testing**

Tools:

1. Manometer
2. Mirror
3. Chemical smoke pencil
4. Stopwatch or watch with second hand
5. Combustion analyzer
6. 1/4" air line tubing
7. Gas leak detector

At the end of each day in which duct sealing or repair is performed, conduct Combustion Appliance Zone (CAZ) testing in accordance with the NREL Manufactured Home Standard Work Specifications, details 2.0201.3a through 2.0201.3h.

6.6204.1a

Desired Outcome:

Verify proper operation of existing systems

Specification(s):

Visual inspection will be performed and documented for:

- Electrical connections
- Name plate (rated sone and flow)
- Damper operation (internal and external)
- Motor cleanliness

Ducts:

- Connections (proper materials, sealed and connected)
- Insulation
- Support
- Sizing
- Termination

Objective(s):

Evaluate systems

6.6204.1b

Desired Outcome:

Verify proper operation of existing systems

Specification(s):

Calibrated device will be used to test for flow measurement

Objective(s):

Ensure proper flow

6.6204.1c

Desired Outcome:

Verify proper operation of existing systems

Specification(s):

Work order will be developed as necessary in accordance with systems check and flow rate

Objective(s):

Correct deficiencies

Ensure proper operation

6.6204.1d

Desired Outcome:

Verify proper operation of existing systems

Specification(s):

Total exhaust and/or supply system ventilation airflow will be measured

Objective(s):

Ensure airflow is as designed

6.6205.1a - Assessment



The blower door number will be used to determine the infiltration credit.



Existing fan flow can be measured for alternate compliance, and new fans must be commissioned to ensure proper flow.

6.6205.1b

Desired Outcome:

Provide primary ventilation for common spaces

Specification(s):

Fan type will be capable of continuous operation and selected in accordance with ASHRAE 62.2 for:

- Sizing
- Climate considerations
- Control strategy
- Sone rating
- Durability

Fan will be ENERGY STAR qualified

Objective(s):

Determine proper fan selection

Minimize energy consumption during fan operation



Fans should be marked with the ENERGY STAR logo.

Sone Rating Limits of 62.2

	Local Exhaust (SPOT) INTERMITTENT	Local Exhaust (SPOT) CONTINUOUS	WHOLE BUILDING
New Fans	3.0	1.0	1.0
Existing Fans	N/A	N/A	1.0

No sone requirement when.....

- Using an existing fan with a timer
- Remote mounted fans (i.e. inline fan in the attic)

Best Practice

6.6205.1c

Desired Outcome:

Provide primary ventilation for common spaces

Specification(s):

No resistance greater than 3 pascals will exist between fan intake location with reference to the common area

Exhaust ventilation for common spaces will not be installed in bathrooms or bedrooms

Objective(s):

Ensure fresh air distribution to common areas



Tools:

1. digital manometer

6.6205.1c - Location



Locate the fan in question.



Connect a hose, and turn the manometer on to PR/PR.



Turn on the exhaust fan.

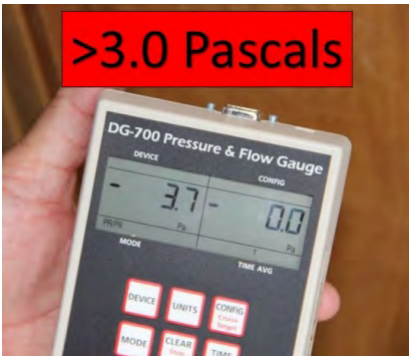

If the pressure difference is greater than 3.0 pascals, pressure relief is needed.



If pressure relief is needed, it can be provided by a through the door transfer grille.

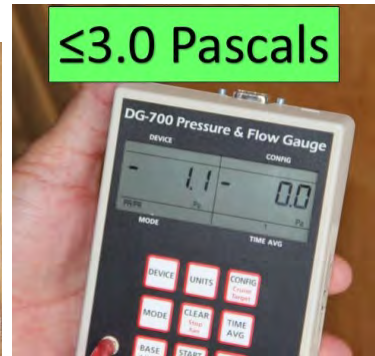

After pressure relief has been provided recheck the numbers, ensuring a reading within range.

6.6205.1d

Desired Outcome:

Provide primary ventilation for common spaces

Specification(s):

ASHRAE 62.2 will be referenced for climate considerations

Whole house mechanical net exhaust flow for hot-humid climate will not exceed 7.5 cubic feet per minute/100 square feet

Objective(s):

Maintain building durability

Protect occupant health

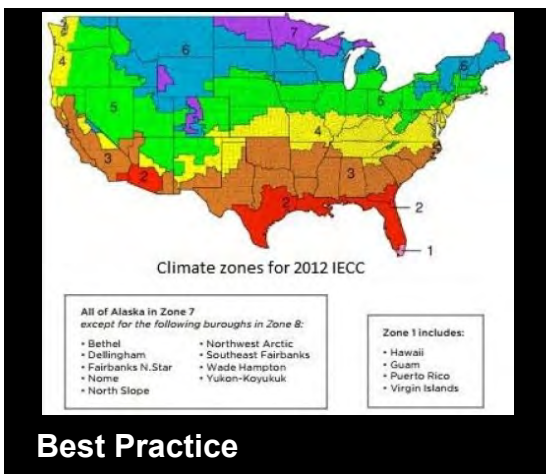

Climate should be considered when selecting a ventilation strategy. Hot humid climate zones require special attention.

6.6205.1e

Desired Outcome:

Provide primary ventilation for common spaces

Specification(s):

CAZ test will be performed where combustion appliances are utilized, where applicable

Objective(s):

Identify possible conditions that can cause unsafe equipment operating conditions

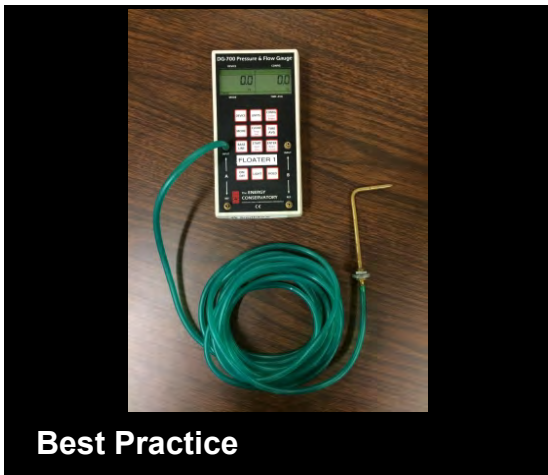

Complete combustion appliance zone testing to ensure a healthy, safe environment

See
**SWS 2.0201.3a-
2.0201.3h**
for CAZ testing

Tools:

1. Manometer
2. Mirror
3. Chemical smoke pencil
4. Stopwatch or watch with second hand
5. Combustion analyzer
6. 1/4" air line tubing
7. Gas leak detector

At the end of each day in which duct sealing or repair is performed, conduct Combustion Appliance Zone (CAZ) testing in accordance with the NREL Manufactured Home Standard Work Specifications, details 2.0201.3a through 2.0201.3h.

6.6205.1f

Desired Outcome:

Provide primary ventilation for common spaces

Specification(s):

Occupant will be educated on:

- Purpose of the ventilation system
- Proper operation and use of controls
- Cost and benefit of system
- Manual shut off

A label indicating the presence and purpose of the ventilation system will be included or a copy of the system operation guide will be posted at the electrical panel

Operation guide or label will be permanently attached and in full sight

Objective(s):

Ensure occupant is educated on the safe and efficient operation of the system

Deliver intended air exchange



Clients should be educated on the purpose and operation of their new ventilation system.



Whole house ventilation should be clearly labeled.

6.6205.1g

Desired Outcome:

Provide primary ventilation for common spaces

Specification(s):

Total exhaust system airflow will be measured

Objective(s):

Ensure exhaust airflow is as designed



In Progress

Measure the fan flow with the flow meter.

Tools:

1. digital manometer
2. exhaust fan flow measuring device

6.6205.1g - Total exhaust airflow



1 Attach hose to the fan meter.



2 Attach hose to the manometer set to PR/PR.



3 Adjust gate on the flow meter as needed.

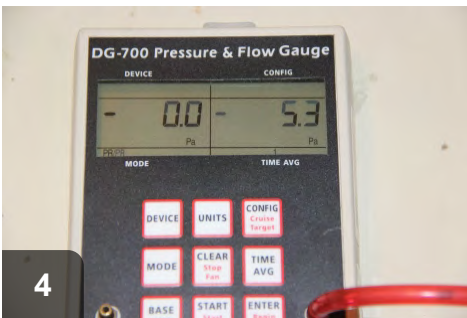

4 With the flow meter in place, read the resulting pressure on the manometer.

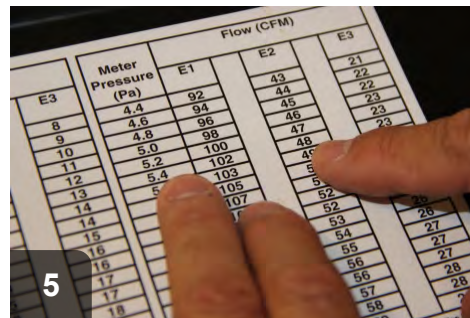

5 Match the pressure reading to the gate selection and read the final CFM flow.

6.6206.1a

Desired Outcome:

Safely and properly eliminate fan

Specification(s):

Power supply will be disconnected and properly terminated in visible junction box

Objective(s):

Safe removal of equipment

Ensure worker safety

6.6206.1b

Desired Outcome:

Safely and properly eliminate fan

Specification(s):

Fan components will be removed and disposed of lawfully

Duct work will be removed if necessary

OR

Fan housing will be left in place, ducts will be removed, and leakage points will be air sealed

Hole will be sealed and insulated to preserve the thermal and pressure boundary

Objective(s):

Remove fan

Preserve aesthetics, and thermal and pressure boundary

6.6206.1c

Desired Outcome:

Safely and properly eliminate fan

Specification(s):

Fan opening will be sealed and insulated

If necessary, the void from the duct work removal will be insulated

Fan termination will be sealed

Objective(s):

Maximize energy efficiency

Preserve the thermal and pressure boundary

6.6206.1d

Desired Outcome:

Safely and properly eliminate fan

Specification(s):

Combustion safety test will be performed where combustion appliances are utilized

Objective(s):

Identify possible conditions that can cause unsafe equipment operating conditions

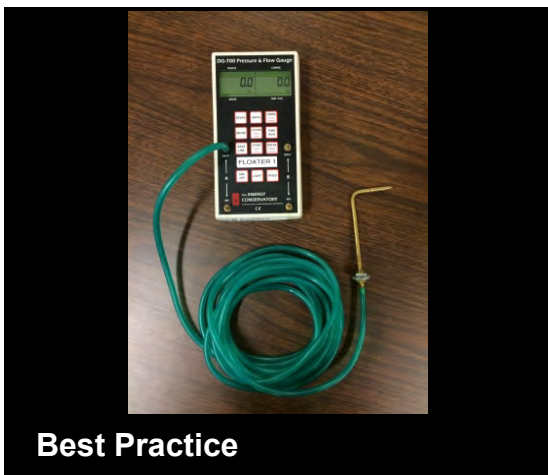

Complete combustion appliance zone testing to ensure a healthy, safe environment

See
**SWS 2.0201.3a-
2.0201.3h
for CAZ testing**

Tools:

1. Manometer
2. Mirror
3. Chemical smoke pencil
4. Stopwatch or watch with second hand
5. Gas leak detector
6. Combustion analyzer
7. 1/4" air line tubing

At the end of each day in which duct sealing or repair is performed, conduct Combustion Appliance Zone (CAZ) testing in accordance with the NREL Manufactured Home Standard Work Specifications, details 2.0201.3a through 2.0201.3h.

6.6288.2a

Desired Outcome:

Systems operate as quietly as possible

Specification(s):

System will be rated at a sound no greater than 1.0 sone

Objective(s):

Minimize noise

Maximize fan use

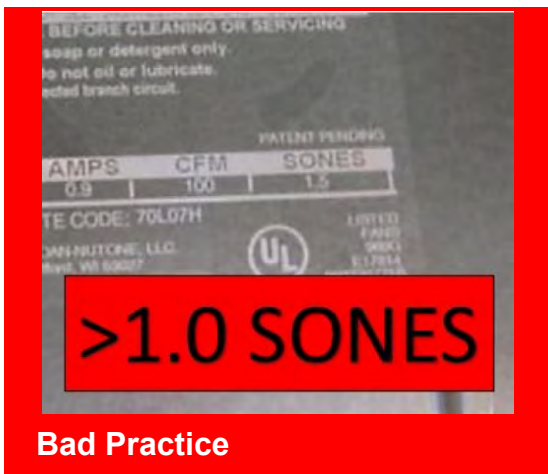

This fan is rated at 1.5 SONES and is NOT acceptable for continuous use.

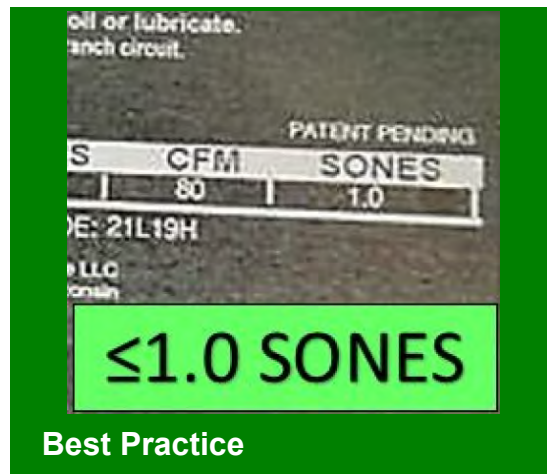

This fan is rated at 1.0 sones and is acceptable for continuous use.

6.6288.2b

Desired Outcome:

Systems operate as quietly as possible

Specification(s):

Spot ventilation (local mechanical exhaust systems operated as needed by the occupant; e.g., range hood, bath fans) will be rated at a sound no greater than 3.0 sone

Objective(s):

Minimize noise

Maximize fan use



Bad Practice

This fan is rated at 3.5 SONES and is NOT acceptable for intermittent use.

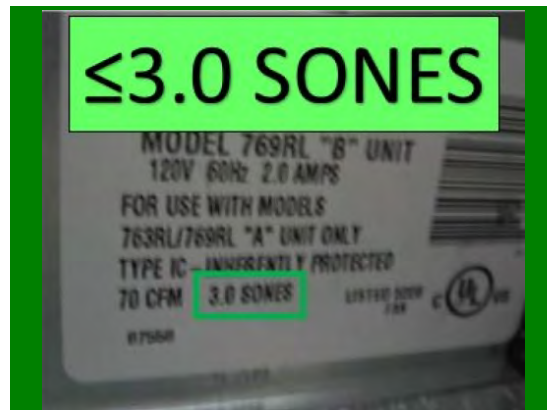

Best Practice

This fan is rated at 3.0 sones and is acceptable for intermittent use.

6.9901.1a

Desired Outcome:

To provide supplemental ventilation information—ASHRAE 62.2

Specification(s):

ASHRAE Standard 62.2-2013 and the calculation of the infiltration credit allow adjustments to primary ventilation fan flow rates for existing houses using a single fan.

Objective(s):

To provide supplemental ventilation information--ASHRAE 62.2

7.8001.1a

Desired Outcome:

A more energy efficient appliance installed

Specification(s):

Appliance will have an efficiency level of at least 40% better than minimum federal requirements

Appliance will fit in the available space without blocking access to light switches, cabinets, etc.

Appliance will carry a minimum one-year warranty that will provide a replacement appliance if repeated issues relating to health, safety, or performance occur

Objective(s):

Ensure occupant satisfaction with appliance

7.8001.1b

Desired Outcome:

A more energy efficient appliance installed

Specification(s):

Appliance will be installed in accordance with manufacturer specifications and local codes

Any penetrations to the exterior of the home created by the installation of the appliance will be sealed

Energy-related appliance controls will be demonstrated to the occupant

Specific information on the proper maintenance of the equipment will be provided to the occupant

Warranty information, operation manuals, and installer contact information will be provided to the occupant

Objective(s):

Achieve intended appliance function

Preserve food at low energy use

Educate occupant on how to operate and maintain the appliance

7.8001.1c

Desired Outcome:

A more energy efficient appliance installed

Specification(s):

Appliances replaced by new units will be recycled or disposed of in accordance with federal, state, or local regulations

Appliances infested with pests will be enclosed before moving

Objective(s):

Prevent reuse of inefficient equipment and components

Protect the environment

Protect worker safety

7.8001.2a

Desired Outcome:

Energy used for food preservation reduced

Specification(s):

Dirty or clogged coils will be cleaned

Air flow to the coils will be provided in accordance with manufacturer specifications

Appliance will be located away from heat sources (e.g., supply registers, direct sunlight) if possible

Interior temperatures will be measured, and the appliance must maintain:

- Freezer temperature at 0°
- Fresh food at 35-40°

Specific information about the proper maintenance of the equipment will be provided to the occupant

Condensation control switch will be left in the appropriate position, given occupant preference and moisture load in the house

Objective(s):

Reduce energy use

Improve performance

Educate occupant on how to operate and maintain the appliance

7.8002.1a

Desired Outcome:

Energy used for electronic entertainment and computer use reduced while effective performance is maintained

Specification(s):

Category of equipment selected will meet occupant preferences and have the lowest available energy use [e.g., plasma vs. light-emitting diode (LED)]

Equipment will have a minimum energy efficiency level of ENERGY STAR

Equipment will be selected that does not have to be left on during non-use periods for updates (e.g., gaming systems, set-top boxes)

Standby losses for system will be one watt or less

Objective(s):

Reduce energy use

Ensure occupant satisfaction with appliance

7.8002.1b

Desired Outcome:

Energy used for electronic entertainment and computer use reduced while effective performance is maintained

Specification(s):

Equipment will be installed in accordance with manufacturer specifications (e.g., air circulation) and meet all applicable codes

Any penetrations to the exterior of the home created by the installation of the equipment will be sealed

All energy saving features will be enabled unless specifically directed otherwise by the occupant

A readily accessible means of disconnection (e.g., power strip, timer) will be provided for equipment that must be disconnected from the power source to avoid standby losses and whose performance will not be damaged by being disconnected

All equipment controls will be demonstrated to the occupant

Specific information about the proper maintenance of the equipment will be provided to the occupant

Warranty information, operation manuals, and installer contact information will be provided to the occupant

Objective(s):

Reduce energy use

Ensure equipment is available for use when needed

Ensure equipment is convenient to turn off when not in use

Educate occupant on how to operate and maintain equipment

7.8002.1c

Desired Outcome:

Energy used for electronic entertainment and computer use reduced while effective performance is maintained

Specification(s):

Equipment will be recycled or disposed of using Environmental Protection Agency (EPA) Responsible Recycling (R2) initiative principles

Objective(s):

Prevent reuse of inefficient equipment and components

Reduce waste

Properly dispose of hazardous materials

7.8003.1a

Desired Outcome:

Energy used for lighting reduced while maintaining adequate and safe lighting levels

Specification(s):

Window coverings (e.g., blinds, shades, moveable insulation) will be replaced or maneuvered to maximize useful daylight where appropriate

Active and passive daylighting will be properly oriented, designed, and installed where appropriate

Objective(s):

Reduce energy use without negative consequences (e.g., glare, unintentional heating)

7.8003.1b

Desired Outcome:

Energy used for lighting reduced while maintaining adequate and safe lighting levels

Specification(s):

All bulbs, fixtures, and controls will be appropriate for the intended application (e.g., enclosed, orientation, dimmable, potential for breakage, indoor and outdoor)

All bulbs, fixtures, and controls will be selected to provide the brightness and light quality required in that application (e.g., task lighting, trip-and- fall hazards, nightlights)

Selected equipment should have the highest level of efficiency within a technology [e.g., compact fluorescent lamp (CFL), LED]

All bulbs, fixtures, and controls will be ENERGY STAR rated where applicable

When possible, bulbs, fixtures, and controls will be selected that will facilitate the use of future lighting technologies (e.g., LEDs)

When incandescent bulbs cannot be replaced or when occupant chooses not to replace, a dimmer will be selected

Power quality will be evaluated before new lighting is selected

Light/lamp wattage should not exceed rated wattage of fixture

Bulb replacements will be chosen based on expected durability, light quality, and lifetime energy use of the bulb

Controls to turn off lights when not needed (e.g., no one in room) will be provided

All bulbs, fixtures, and controls will be UL-approved and installed in accordance with local code(s) and NFPA 70 National Electric Code

Fluorescent light ballasts containing polychlorinated biphenyls (PCBs) will be replaced in accordance with the EPA's Healthy Indoor Environment Protocols for Home Energy Upgrades

Objective(s):

Provide improved lighting quality at lower energy use

Select equipment that will not be an unnecessary barrier to future technologies

Avoid inferior products and unsatisfied occupants

7.8004.1a

Desired Outcome:

Energy and environmental impact for washing clothes reduced

Specification(s):

Minimum appliance efficiency will be ENERGY STAR and Water Sense or better

Classes within ENERGY STAR standards will be considered so as to achieve greater savings

Adequate clearance will be maintained around appliance when fit into available space so access to cabinets and light switches are not blocked

Appliance will be covered by a minimum one-year warranty

Equipment will be selected with features that reduce peak electric demand, absolute energy use, and water use

Standby losses for equipment will be one watt or less

Objective(s):

Reduce energy use

Ensure occupant satisfaction with appliance

7.8004.1b

Desired Outcome:

Energy and environmental impact for washing clothes reduced

Specification(s):

Appliance will be installed in accordance with manufacturer specifications (e.g., leveling, plumbing connection, electrical connection, interior lighting) and meet all applicable codes

Shut-off valves will be installed by a licensed plumber or other qualified contractor in accordance with the authority having jurisdiction, if not already present

Hoses that can withstand water pressure at the location will be installed

If located in conditioned or finished area, overflow pan will be installed and drained to a safe location

Any penetrations to the exterior of the home created by the installation of the appliance will be sealed

Energy-related appliance controls will be demonstrated to the occupant

Specific information about proper maintenance of the equipment will be provided to the occupant

Water quality will be evaluated using a pH and hardness tests, and the occupant will be informed on detergent levels and type to optimize performance

Warranty information, operation manuals, and installer contact information will be provided to the occupant

Objective(s):

Ensure equipment functions as designed

Reduce water consumption

Prevent water damage

Educate occupants on how to maintain washer to ensure savings

7.8004.1c

Desired Outcome:

Energy and environmental impact for washing clothes reduced

Specification(s):

Replaced appliances will be recycled or removed in accordance with local regulations, including older equipment switches containing mercury

Objective(s):

Prevent the reuse of inefficient equipment and its components

Reduce waste

Ensure occupant health

7.8004.2a

Desired Outcome:

Energy and environmental impact for drying clothes reduced

Specification(s):

Total energy use will be factored into the selection process if fuel switching is being considered

Dryer will be equipped with moisture sensor

Equipment will be selected with energy features that reduce both peak electric demand and absolute energy use

Standby losses for equipment will be one watt or less

A dryer best matched to the venting options will be selected (e.g., central location, length of vent, cost of venting)

Appliance will be covered by a minimum one-year warranty

Objective(s):

Reduce energy use

Avoid increasing total energy use (gas and electric) when fuel switching

7.8004.2b

Desired Outcome:

Energy and environmental impact for drying clothes reduced

Specification(s):

Appliance will be installed in accordance with manufacturer specifications (e.g., leveling, plumbing connection, electrical connection, interior lighting) and meet all applicable codes

If existing venting does not meet the following criteria (as well as manufacturer specifications and applicable codes), new venting will be installed using the following specifications:

- Appliance will be vented to the outside using metal-to-metal or UL-listed foil-type venting material
- Venting design will meet standards for optimal venting
- Venting will not be constricted or blocked
- Only screws will be used to connect metal-to-metal and must not catch lint inside venting material
- Only clamps will be used on semi-rigid metal and UL-listed foil-type venting materials
- Pest screen will be installed at the termination
- At least 3' of the vent closest to the exterior of the house will be insulated with a minimum of R-6

All dryers, other than condensing dryers, will be vented to the outdoors

If a combustion appliance is used, combustion safety testing will be performed in accordance with the Health and Safety Chapter of the Standard Work Specifications for Single-Family Housing or other equivalent practice

Any penetrations to the exterior of the home created by the installation of the appliance will be sealed

Energy-related appliance controls will be demonstrated to the occupant

Specific information of the proper maintenance of the equipment will be provided to the occupant

Warranty information, operation manuals, and installer contact information will be provided to the occupant

Objective(s):

Ensure equipment functions as designed

Install appliance safely and effectively

Ensure house as a whole system is not adversely affecting the proper functioning/venting of equipment

Reduce energy use

In case of fuel switching, reduce cost

7.8004.2c

Desired Outcome:

Energy and environmental impact for drying clothes reduced

Specification(s):

Replaced appliances will be recycled or removed and disposed of in accordance with local regulations, including older equipment switches containing mercury

Objective(s):

Prevent the reuse of inefficient equipment and its components

Reduce waste

Ensure occupant health

7.8101.1a

Desired Outcome:

Energy and water use reduced while occupant needs for water flow maintained

Specification(s):

Installer prework assessment will be conducted to determine if plumbing needs corrected before installing high-efficiency shower head or faucet

Objective(s):

Verify scope of work

7.8101.1b

Desired Outcome:

Energy and water use reduced while occupant needs for water flow maintained

Specification(s):

The rated flow of new shower heads will be 2.5 gallons per minute (GPM) or less

If multiple heads are provided, the total flow rate will not exceed 2.5 GPM

Aerator flow rate will be 2.2 GPM or less

All work shall be completed by a licensed plumbing professional where required by the authority having jurisdiction and installed to industry-accepted standards

Objective(s):

Reduce water and energy consumption

Ensure occupant satisfaction



2.5 GPM stamp on a shower head



Shower and faucet aerators with flow rates equal to or less than 2.5 and 2.2 gpm

Tools:

1. Tongue-and-groove pliers

Materials:

1. Joint sealing tape
2. Shower and faucet aerators

Verify that occupant is satisfied with the performance of their shower and faucet aerators. Offer acceptable alternatives that meet the flow requirements.

7.8101.1c

Desired Outcome:

Energy and water use reduced while occupant needs for water flow maintained

Specification(s):

Equipment will be installed in accordance with manufacturer specifications and meet all applicable building codes

Water quality will be evaluated for debris that may clog the equipment

Once installed, high-efficiency shower heads or faucet aerators will be tested to determine if equipment is tightened adequately to prevent leakage at the point of connection

If needed, shower diverter will be repaired or replaced

Any penetrations to the exterior of the home created by the installation of the equipment will be sealed

Any damage done to the house during installation will be repaired

Specific information about proper maintenance of the equipment will be provided to the occupant

Warranty information, operation manuals, and installer contact information will be provided to the occupant

Water flow that satisfies the occupant will be provided by all shower heads and faucet aerators

Occupant's acceptance of the shower head and/or aerator will be documented

Objective(s):

Reduce water and energy consumption

Ensure occupant satisfaction with water flow

Eliminate water leakage

Prevent water damage



Before

Old, high flow shower nozzle

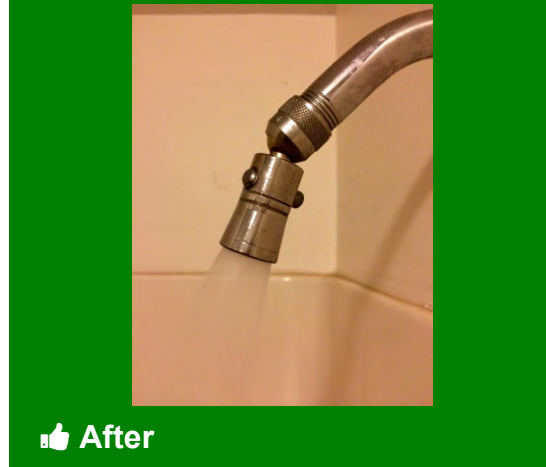

After

Leak testing a new shower aerator

Tools:

1. Tongue-and-groove pliers
2. Pipe wrench
3. Adjustable wrench

Materials:

1. Joint sealing tape
2. Rags

Interview occupant to document and verify their satisfaction with new shower and faucet aerators. Operate equipment after installation to ensure that it does not leak.

7.8101.1c - Installation



1 Remove old, high flow shower heads



2 Replace with 2.5 gpm maximum shower heads



3 Clean corrosion and old sealant from the threads on the shower nipple using a wire brush



4 Seal the threads on the shower nipple with two wraps of Teflon tape. Wrap tape clockwise so it won't peel off

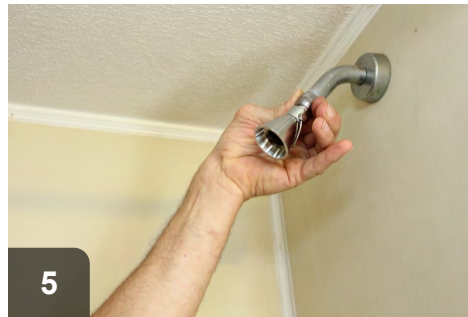

5 Install the new low-flow shower head



6 Tighten the shower head using an adjustable wrench or tongue-and-groove pliers and a rag to protect the finish.

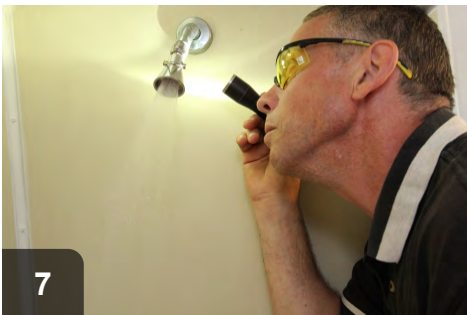

7 Turn on the water and check for leaks



8 Make sure the client is happy with their new low-flow shower head. Document approval with their signature in the file

7.8101.1d

Desired Outcome:

Energy and water use reduced while occupant needs for water flow maintained

Specification(s):

Replaced shower heads and faucet aerators will be recycled or disposed of properly

Objective(s):

Prevent the reuse of inefficient equipment and components



Recycle or dispose of removed shower faucets and sink aerators to prevent their reuse.

7.8102.1a

Desired Outcome:

Safe, reliable, and efficient hot water source selected that meets occupant needs at lowest possible cost of ownership and operation

Specification(s):

Equipment will provide sufficient, affordable, safe, and healthy hot water for the occupant in accordance with 2012 IRC P2801

Potential for solar hot water heating or other renewable energy systems will be assessed in selecting the hot water equipment

Potential for health and safety hazards (e.g., back drafting, flame rollout, obstructions) will be assessed in selecting equipment, and the cost of remedying such problems will be included in any cost and benefit calculations

If a combustion-based system is selected, it will be either direct vented or power vented, and ENERGY STAR® qualified or an Energy Factor (EF) of 0.58 or higher

If combustion equipment is selected, a low nitrogen oxide burner will be included

Equipment will be functional at high efficiency under all load conditions

Standby losses will be reduced to maximum potential

Fuel type will be selected based on affordability to occupant

Equipment will be freeze resistant or installed in a conditioned space

Efficiency of equipment will be maintained throughout life of system

Occupant control of hot water temperature will be provided on the equipment

The following will be determined from the occupant:

- Lifestyle
- Current and future needs
- Space considerations
- Fuel options
- Health and safety considerations
- Appliance options

- Maintenance and operation cost
- Return on investment concerns

Objective(s):

Save energy and water

Protect the environment

Identify appliance options based on the needs and wants of the occupant

7.8102.1b

Desired Outcome:

Safe, reliable, and efficient hot water source selected that meets occupant needs at lowest possible cost of ownership and operation

Specification(s):

Water heater will be selected based on performance requirements of the occupant, available fuel sources, energy efficiency, and total life cycle cost

In very cold climates, on-demand water heaters will be sized to meet the demand of water flow at very low water intake temperatures

When evaluating an existing thermal solar water heating system, a solar expert should be consulted

The proper installation and maintenance of solar hot water systems is provided in the Uniform Solar Energy Code (USEC) and 2012 IRC Chapter 23

Objective(s):

Ensure equipment meets the occupant's expectations while providing efficient energy and water use

7.8102.2a

Desired Outcome:

Safe and reliable hot water source provided that meets occupant needs at lowest possible cost of ownership

Specification(s):

Health concerns in the removal and replacement of equipment (e.g., asbestos, other hazardous materials) will be identified

Written notification will be provided to occupants of the discovery of hazardous material, including contact information for regional EPA asbestos coordinator

Occupant will be asked to contract with an EPA-certified asbestos contractor to conduct abatement before equipment removal and replacement (occupant is responsible for abatement or remediation)

Objective(s):

Remediate health hazards using EPA- certified contractors

7.8102.2b

Desired Outcome:

Safe and reliable hot water source provided that meets occupant needs at lowest possible cost of ownership

Specification(s):

Accepted industry procedures and practices will be followed to:

- Remove old water heater and associated components in accordance with 2012 IRC R105.1 or authority having jurisdiction
- Seal any unused chimney openings and penetrations in accordance with 2012 IRC N1102.4.1.1 or authority having jurisdiction
- Remove unused oil tank, lines, valves, and associated equipment in accordance with 2012 IRC M2201.7 or authority having jurisdiction

All work shall be completed by a licensed plumbing professional where required by the authority having jurisdiction and installed to industry-accepted standards

Objective(s):

Ensure the safety of the workers and occupants

Preserve integrity of the building

Remove old equipment in a timely and efficient manner

7.8102.2c

Desired Outcome:

Safe and reliable hot water source provided that meets occupant needs at lowest possible cost of ownership

Specification(s):

New water heater and associated components will be installed by a licensed contractor to accepted industry standards, in accordance with the 2012 IRC and manufacturer specifications

The system will be installed to be freeze resistant

Any existing water leaks will be repaired before installation begins

Any penetrations to the exterior of the home created by the installation of the equipment will be sealed

Objective(s):

Ensure the safety of the workers and occupants

Preserve integrity of the building

Remove old equipment in a timely and efficient manner

7.8102.2d

Desired Outcome:

Safe and reliable hot water source provided that meets occupant needs at lowest possible cost of ownership

Specification(s):

An emergency drain pan will be installed with sides that extend a minimum of 4" above floor if leakage would cause damage to the home and in accordance with P2801.5 of the 2012 IRC

A $\frac{3}{4}$ " drain line or larger will be connected to tapping on pan and terminated in accordance with P2801.5.2 of the 2012 IRC

Objective(s):

Collect and safely dispose of water escaping from the storage tank

7.8102.2e

Desired Outcome:

Safe and reliable hot water source provided that meets occupant needs at lowest possible cost of ownership

Specification(s):

A potable water expansion tank will be installed on the cold water side

A direct connection with no valves between the storage tank and expansion tank will be installed in accordance with the 2012 IRC, authority having jurisdiction, and according to manufacturer specifications

Objective(s):

Protect the storage tank from expansion



Bad Practice

Need to eliminate the valves between the storage tank and expansion tank



Best Practice

Expansion tank is installed on the cold water supply side

Appropriate licensing for installer required. Expansion tanks are only required to be installed only when in conjunction with new and replacement water heaters.

7.8102.2f

Desired Outcome:

Safe and reliable hot water source provided that meets occupant needs at lowest possible cost of ownership

Specification(s):

Correct temperature and pressure relief valve will be installed in compliance with P2803 of the 2012 IRC and according to manufacturer specifications

Temperature and pressure relief valve discharge tube will be installed in accordance with P2803.6.1 of the 2012 IRC

Objective(s):

Discharge excessive energy (pressure or temperature) from storage tank to safe location

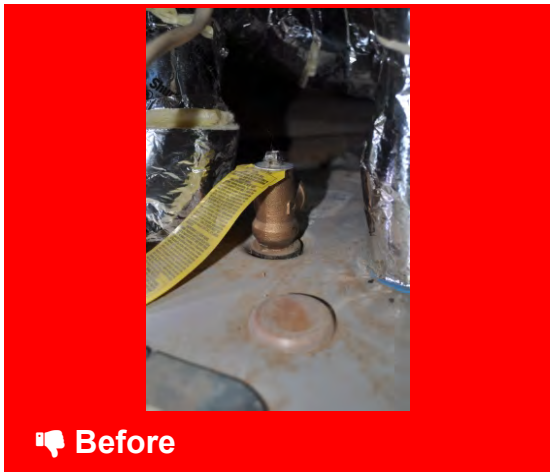

Before

Water heaters should be not capped of at t&p valve

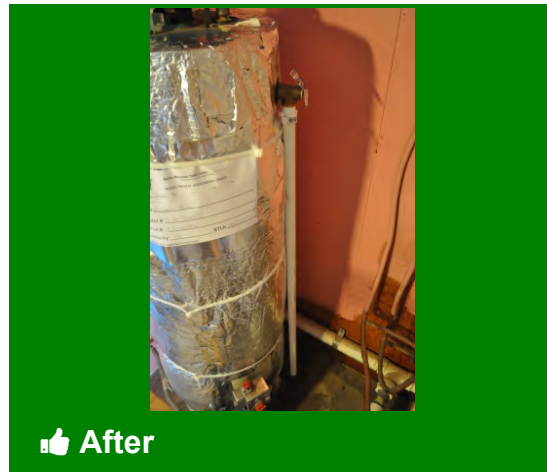

After

T&P discharge should be piped to a safe and observable location

Tools:

1. Pipe wrench
2. Hacksaw

Materials:

1. PVC
2. Plumber's epoxy

Check local jurisdictional codes. Paraphrased from 2012 IRC P2803.6.1: Temperature and pressure relief valve discharge pipes should not be connected to drainage system. T&P discharge pipes should be a clean line without valve or tee, flowing with gravity to an observable and safe location that cannot cause personal injury or structural damage -- the floor, an existing drain pan, a waste receptor, or to the outdoors. Pipe should not terminate more than 6" from floor, pan or waste receptor.

7.8102.2f - Temperature and pressure relief valve



GOOD: T&P discharge should be piped within 6" of the floor or to outdoors



BAD: T&P discharge should flow with gravity and be observable



BAD: T&P discharge should not be piped into drainage system

7.8102.2g

Desired Outcome:

Safe and reliable hot water source provided that meets occupant needs at lowest possible cost of ownership

Specification(s):

Dielectric unions will be installed in accordance with the 2012 IRC, authority having jurisdiction, and according to manufacturer specifications

Objective(s):

Break the stray voltage electrical circuit through the storage tank

7.8102.2h

Desired Outcome:

Safe and reliable hot water source provided that meets occupant needs at lowest possible cost of ownership

Specification(s):

Backflow prevention will be installed in accordance with manufacturer specifications and all applicable codes

Objective(s):

Protect water supply from contamination

7.8102.2i

Desired Outcome:

Safe and reliable hot water source provided that meets occupant needs at lowest possible cost of ownership

Specification(s):

If additional tank insulation is installed, it will be rated a minimum of R-11 and will be installed to manufacturer specifications

If additional insulation is installed, it will be installed based on fuel type, making sure not to obstruct draft diverter, pressure relief valve, thermostats, hi-limit switch, plumbing pipes or elements, and thermostat access plates

The first 6' of inlet and outlet piping will be insulated in accordance with manufacturer specifications

Pipe insulation must remain 3" from gas water heater vent

Heat traps will be installed on the inlet and outlet piping where not provided by manufacturer

Objective(s):

Reduce standby loss from near tank piping and storage tank

Ensure insulation does not make contact with flue gas venting

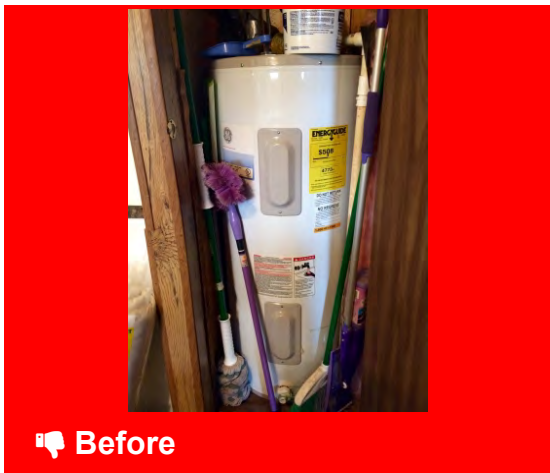

Before

Uninsulated storage-type water heater



After

Storage-type water heater with additional insulation

Tools:

1. Outward clinching (stitch) stapler
2. Utility knife
3. Scissors
4. Straight edge

Materials:

1. R-11 tank wrap
2. Vinyl tape
3. Staples
4. Rags or terry-cloth towels
5. Foam pipe insulation

Check warning labels on tanks. Not all water heaters may be insulated. Leave the tops of gas water heaters uninsulated, and be sure to keep combustion chamber access panels and combustion air holes uncovered. Cut out around thermostats on electric units. Use staples or zip ties to mechanically fasten insulation in place. Do not rely on tape alone to hold the tank wrap. Maintain proper clearance from gas appliance vents to combustibles.

7.8102.2i - Thermal efficiency



1 Clean the entire outside of the water heater

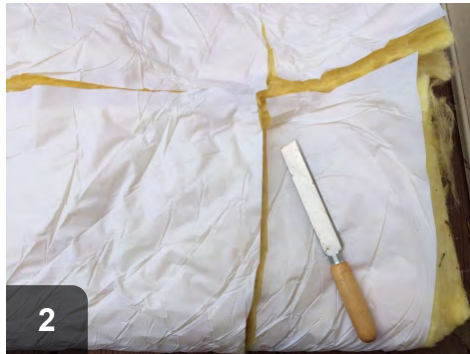

2 Wrap blanket around tank and mark it where it overlaps. Add two or three inches and cut off using a straightedge and raz



3 Cut the insulation off at the mark. Peel away the excess insulation, leaving a flap of vapor barrier

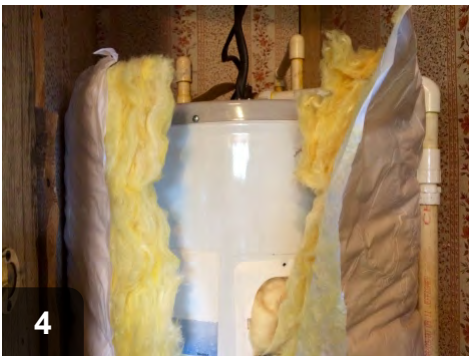

4 Pull insulation blanket around the tank



5 Staple the flap to the blanket with outward clinching staples or use long zip ties to secure the blanket in place



6 Cut out around drain valve, P&T relief valve, and thermostats. Do not cover combustion access or air supply on gas units



7 Use remaining insulation for the top of electric water heaters. Tape up seams in the vapor barrier. Insulate water lines

7.8102.2j

Desired Outcome:

Safe and reliable hot water source provided that meets occupant needs at lowest possible cost of ownership

Specification(s):

Electric or fossil fuel supply components will be installed to accepted industry standards as per NFPA 31 and 54, or NFPA 70 National Electric Code (NEC) for electric components, or authority having jurisdiction

Objective(s):

Provide sufficient fuel to the water heater, burner, or element

7.8102.2k

Desired Outcome:

Safe and reliable hot water source provided that meets occupant needs at lowest possible cost of ownership

Specification(s):

Discharge temperature will be set not to exceed 120° or as prescribed by local code

Objective(s):

Ensure safe hot water supply temperature to fixtures



Unsafe

Water heaters producing water over 120 degrees raise heating costs



Safe

Water heaters should produce water under 120 degrees to prevent scalding

Tools:

1. Thermometer

7.8102.2k - Discharge temperature



1 Test temperature of hot water at faucets in house



2 Hot water temperatures should not exceed 120 degrees Fahrenheit



3 Adjust water heater settings and insulate as needed



4 After adjustment and insulation, retest to verify temp is under 120 degrees

7.8102.2I

Desired Outcome:

Safe and reliable hot water source provided that meets occupant needs at lowest possible cost of ownership

Specification(s):

The following will be checked once the system has been filled and purged:

- Safety controls
- Combustion safety and efficiency
- Operational controls
- Fuel and water leaks
- Local code requirements

Commissioning will be in compliance with manufacturer specifications and relevant industry standards

Objective(s):

Ensure safe system function

Keep cost of ownership as low as possible

7.8102.2m

Desired Outcome:

Safe and reliable hot water source provided that meets occupant needs at lowest possible cost of ownership

Specification(s):

Carbon monoxide alarms will be installed in each dwelling in accordance with ASHRAE 62.2 and authority having local jurisdiction

Occupant will be provided information regarding the health effects and risk of high CO concentrations, as well as a list of monitors that can provide more detail regarding CO levels

Ambient CO to be maintained at or under 10 ppm or within acceptable limits as comparable to outside concentrations

Objective(s):

Ensure occupant life safety; CO alarms are designed to detect levels at which occupants might become unable to evacuate

7.8102.2n

Desired Outcome:

Safe and reliable hot water source provided that meets occupant needs at lowest possible cost of ownership

Specification(s):

Completed work will be reviewed

Occupants will be educated on the safe and efficient operation and maintenance of the system, including:

- Adjustment of water temperature and target temperature in accordance with local code
- Periodic drain and flush
- Expansion tank and backflow preventer (no occupant maintenance required)
- Periodic inspection, maintenance, or replacement

Objective(s):

Ensure occupant is informed of the safe, efficient operation and maintenance of the system

7.8102.3a

Desired Outcome:

Safe and reliable hot water source provided that meets occupant needs at lowest possible cost of ownership

Specification(s):

Health concerns in the removal and replacement of equipment (e.g., asbestos, other hazardous materials) will be identified

Written notification will be provided to occupants of the discovery of hazardous material, including contact information for regional EPA asbestos coordinator

Occupants will be asked to contract with an EPA-certified asbestos contractor to conduct abatement before equipment removal and replacement (occupant is responsible for abatement or remediation)

Objective(s):

Remediate health hazards using EPA- certified contractors

7.8102.3b

Desired Outcome:

Safe and reliable hot water source provided that meets occupant needs at lowest possible cost of ownership

Specification(s):

Accepted industry procedures and practices will be followed to:

- Remove old water heater and associated components in accordance with 2012 IRC R105.1
- Seal any unused chimney openings and penetrations in accordance with 2012 IRC N1102.4.1.1
- Remove unused oil tank, lines, valves, and associated equipment in accordance with 2012 IRC M2201.7

All work shall be completed by a licensed plumbing professional where required by the authority having jurisdiction and installed to industry-accepted standards

Objective(s):

Ensure the safety of the workers and occupants

Preserve integrity of the building

Remove old equipment in a timely and efficient manner

7.8102.3c

Desired Outcome:

Safe and reliable hot water source provided that meets occupant needs at lowest possible cost of ownership

Specification(s):

A new water heater and associated components will be installed to accepted industry standards, in accordance with the 2012 IRC, authority having jurisdiction, and manufacturer specifications

All work shall be completed by a licensed plumbing professional where required by the authority having jurisdiction

Objective(s):

Ensure the safety of the workers and occupants

Preserve integrity of the building

Remove old equipment in a timely and efficient manner

7.8102.3d

Desired Outcome:

Safe and reliable hot water source provided that meets occupant needs at lowest possible cost of ownership

Specification(s):

An emergency drain pan will be installed with sides that extend a minimum of 4" above floor if leakage would cause damage to the home and in accordance with P2801.5 of the 2012 IRC

A ¾" drain line or larger will be connected to tapping on pan and terminated in accordance with P2801.5.2 of the 2012 IRC

Objective(s):

Collect and safely dispose of water escaping from the storage tank



Emergency drain pan with drain piped to outside

Tools:

1. PVC cutters
2. Tongue-and-groove pliers

Materials:

1. 4" deep drain pan
2. ¾" or 1" PVC drain fittings and pipe
3. PVC cement

7.8102.3e

Desired Outcome:

Safe and reliable hot water source provided that meets occupant needs at lowest possible cost of ownership

Specification(s):

Correct temperature and pressure relief valve will be installed in compliance with P2803 of the 2012 IRC and according to manufacturer specifications

Temperature and pressure relief valve discharge tube will be installed in accordance with P2803.6.1 of the 2012 IRC

Objective(s):

Discharge excessive energy (pressure or temperature) from storage tank to safe location



 Before

Water heaters should be not capped of at t&p valve



 After

T&P discharge should be piped to a safe and observable location

Tools:

1. Pipe wrench
2. Hacksaw

Materials:

1. PVC
2. Plumber's epoxy

Check local jurisdictional codes. Paraphrased from 2012 IRC P2803.6.1: Temperature and pressure relief valve discharge pipes should not be connected to drainage system. T&P discharge pipes should be a clean line without valve or tee, flowing with gravity to an observable and safe location that cannot cause personal injury or structural damage -- the floor, an existing drain pan, a waste receptor, or to the outdoors. Pipe should not terminate more than 6" from floor, pan or waste receptor.

7.8102.3e - Temperature and pressure relief valve



GOOD: T&P discharge should be piped within 6" of the floor or to outdoors



BAD: T&P discharge should flow with gravity and be observable



BAD: T&P discharge should not be piped into drainage system

7.8102.3f

Desired Outcome:

Safe and reliable hot water source provided that meets occupant needs at lowest possible cost of ownership

Specification(s):

Dielectric unions will be installed to accepted industry standards, in accordance with the 2012 IRC, and according to manufacturer specifications

Objective(s):

Break the stray voltage electrical circuit through the storage tank

7.8102.3g

Desired Outcome:

Safe and reliable hot water source provided that meets occupant needs at lowest possible cost of ownership

Specification(s):

Backflow prevention will be installed in accordance with manufacturer specifications

House water pressure and volume will be verified as sufficient to be in accordance with manufacturer specifications

All applicable codes will be followed

Objective(s):

Protect the water supply from contamination

Provide for sufficient volume and pressure

7.8102.3h

Desired Outcome:

Safe and reliable hot water source provided that meets occupant needs at lowest possible cost of ownership

Specification(s):

Any accessible hot water lines at the appliance will be insulated to meet 2012 IRC N1103.4.2 or local requirements, whichever is greater

Objective(s):

Reduce line losses



Insulate accessible pipes to R-3 or better

Materials:

1. Foam pipe insulation
2. Spray adhesive
3. Zip ties

Hot water pipe insulation requirements are found in Chapter 11 of the International Residential Code, Section N1103.4.2 (R403.4.2). The code calls for a minimum of R-3. As a best practice, R-4 and R-5 pipe insulation is available through mechanical and industrial suppliers.

Maintain proper clearances from the water heater vent when installing foam pipe insulation.

7.8102.3i

Desired Outcome:

Safe and reliable hot water source provided that meets occupant needs at lowest possible cost of ownership

Specification(s):

Recommendations will be made to install all on-demand appliances as sealed combustion

If not possible:

Combustion and ventilation (excess air) requirements of gas-fired appliances, including provision of outside and inside air to account for building tightness, will be provided

The minimum required volume shall be 50 cubic feet per 1,000 Btu/h in accordance with 2012 IRC G2407.5.1

If needed, additional combustion air will be provided in accordance with 2012 IRC G2407

Objective(s):

Ensure adequate combustion air for operation of the appliance

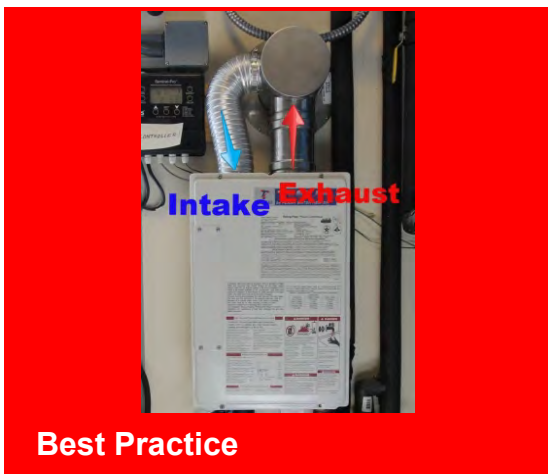

Best practice is to install on-demand water heaters as direct-vent units



If not installed as direct vent, refer to notes and images on next page for required combustion air

To determine adequate combustion air: add up the input Btus of all combustion appliances in the space and divide by 20. The result is the minimum required air volume in cubic feet (50 cubic feet per 1,000 input Btus). If the available volume is less than 50 cubic feet per 1,000 input Btus, provide additional combustion air as listed below for each circumstance, in accordance with the 2012 IRC G2407.

Image 1: For homes with one permanent opening, see 2012 IRC: G2407.6.2 (304.6.2): a minimum free area of 1 in² per 3,000 Btu/h (734 mm²/kW) of total input rating of all appliances

Image 2: For homes with two permanent vertical duct openings, see 2012 IRC G2407.6.1 (304.6.1): a minimum free area of 1 in² per 4,000 Btu/h (550 mm²/kW) of total input rating of all appliances

Image 3: For homes with two permanent horizontal duct openings, see 2012 IRC G2407.6.1 (304.6.1): a minimum free area of 1 in² per 2,000 Btu/h (1,100 mm²/kW) of total input rating of all appliances

7.8102.3i - Required combustion air

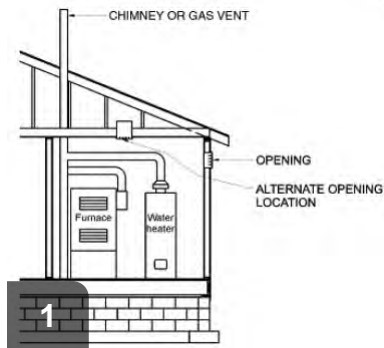

min free area of 1 sqin per 3,000 Btu/h (734 mm²/kW) of total input rating

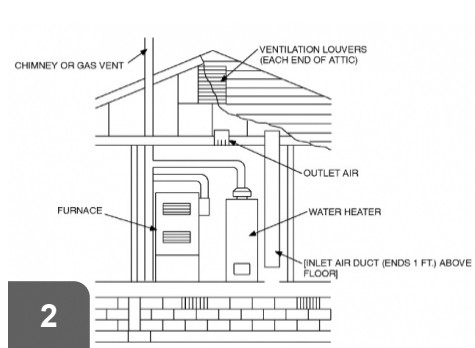

min free area of 1 sqin per 4,000 Btu/h (550 mm²/kW) of total input rating

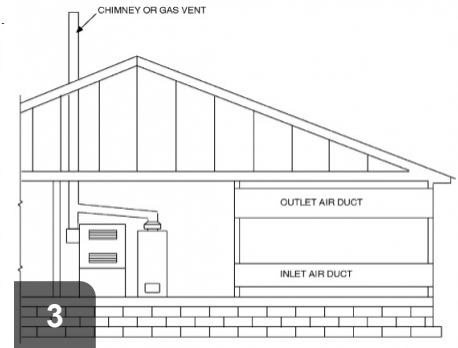

min free area of 1 sqin per 2,000 Btu/h (1100 mm²/kW) of total input rating

7.8102.3j

Desired Outcome:

Safe and reliable hot water source provided that meets occupant needs at lowest possible cost of ownership

Specification(s):

Combustion byproducts will be removed in accordance with Chapter 24 of the International Residential Code (2012 IRC) and manufacturer specifications

Objective(s):

Ensure the safety and durability of the venting system

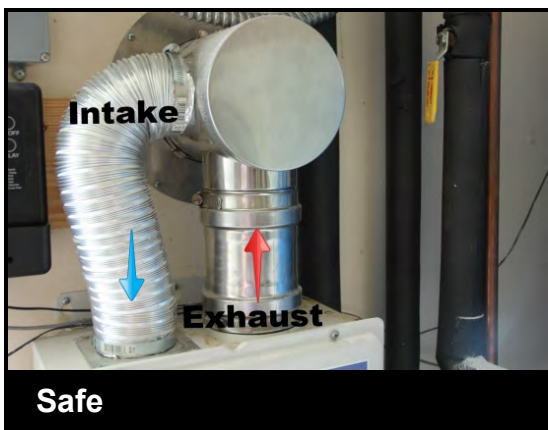

On-demand water heater combustion air intake and exhaust vent, interior view



On-demand water heater combustion air intake and exhaust vent

Follow manufacturer's venting instructions for on-demand appliances. Local codes may be more stringent than the International Residential Code (Section G2407), which governs venting of gas appliances,

Do not locate vent terminals near dryer vents.

7.8102.3j - Venting of flue gases

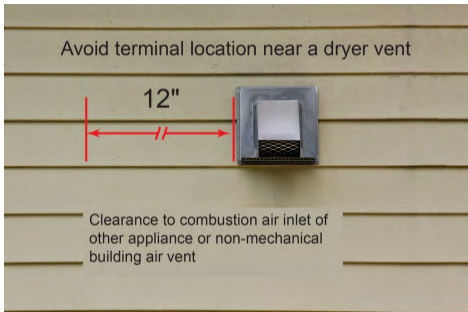

Leave 12" between a vent terminal and any non-mechanical building vent or combustion air inlet from another appliance

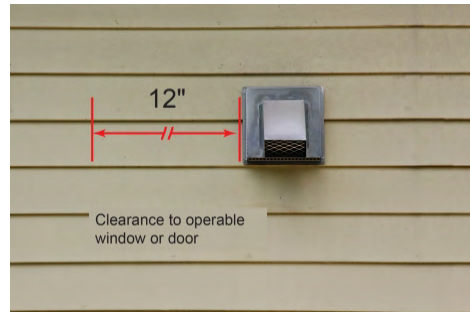

Leave 12" between vent terminals and any operable door or window

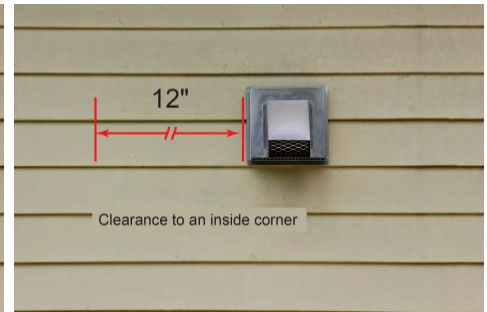

Allow 12" clearance from the edge of a vent to any inside corner of the building

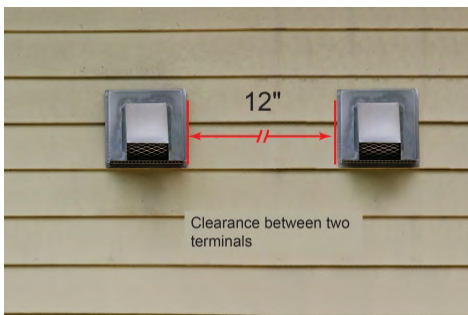

Allow 12" between any two vent terminals

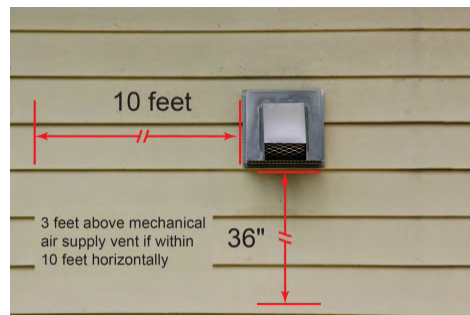

Install vent terminal at least 3 feet higher than any mechanical air inlet that is closer than 10 feet away horizontally

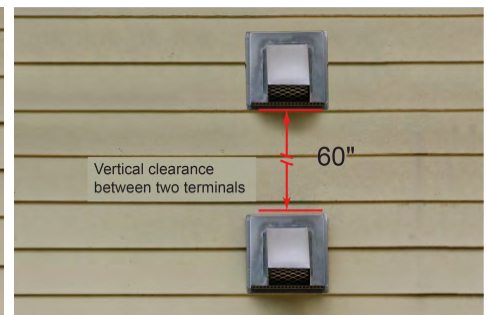

Leave 60" between terminals that are in line vertically



Install vent terminals at least 36" below any eave, soffit, porch, or deck within 24 horizontal inches of center of vent



Install vent at least 36" above grade, porch, deck, veranda, or snow line

7.8102.3k

Desired Outcome:

Safe and reliable hot water source provided that meets occupant needs at lowest possible cost of ownership

Specification(s):

Undiluted flue gases will be checked with a calibrated combustion analyzer in accordance with BPI-1100-T-2012

If combustion is not in compliance with BPI-1100-T-2012, diagnostics and adjustments will be done to manufacturer specifications or local codes

Objective(s):

Confirm that combustion is occurring safely with maximum efficiency

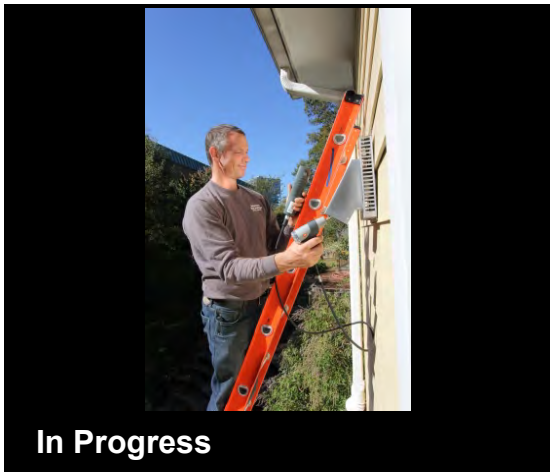

Test flue gases with properly calibrated equipment

Tools:

1. Properly calibrated combustion analyzer

The combustion analyzer shall be calibrated in accordance with the manufacturer's recommendations with available documentation traceable to the individual device.

7.8102.3k - Flue gas testing



Verify that calibration date is current on combustion analyzer



Test flue gases for carbon monoxide at outlet of vent



Verify that carbon monoxide levels are within specifications

7.8102.3I

Desired Outcome:

Safe and reliable hot water source provided that meets occupant needs at lowest possible cost of ownership

Specification(s):

Electric or fossil fuel supply components will be installed to accepted industry standards as per Chapter 24 of the 2012 IRC, the NFGC, NFPA 31, 54, and 58 for gas and oil, or NFPA 70 National Electric Code for electric

Energy input required by the appliance will be in accordance with manufacturer specifications

Objective(s):

Provide sufficient fuel to the water heater burner or element

7.8102.3m

Desired Outcome:

Safe and reliable hot water source provided that meets occupant needs at lowest possible cost of ownership

Specification(s):

The volume and pressure of the water supplied to the appliance will be in accordance with manufacturer specifications

Objective(s):

Provide sufficient volume and pressure of water to the appliance

7.8102.3n

Desired Outcome:

Safe and reliable hot water source provided that meets occupant needs at lowest possible cost of ownership

Specification(s):

Discharge temperature will be set in accordance with manufacturer instructions and in compliance with local codes

Use extreme caution when temperature setting is above 120°F

Objective(s):

Ensure safe hot water supply temperature to fixtures



Hot water temperature over 120°F



Hot water temperature under 120°F

Tools:

1. Thermometer
2. Cup or bowl

Use a thermometer to measure hot water temperature. 120°F is the recommended setting

7.8102.3o

Desired Outcome:

Safe and reliable hot water source provided that meets occupant needs at lowest possible cost of ownership

Specification(s):

The following will be checked once the system has been connected and filled:

- Safety controls
- Combustion safety and efficiency
- Operational controls
- Fuel and water leaks
- Cycle unit
- Local code requirements

Manufacturer specifications and all relevant industry standards will be met in commissioning

Objective(s):

Ensure system functions safely with lowest possible cost of ownership

7.8102.3p

Desired Outcome:

Safe and reliable hot water source provided that meets occupant needs at lowest possible cost of ownership

Specification(s):

All homes with combustion appliances or an attached garage will have a carbon monoxide (CO) alarm

Objective(s):

Ensure occupant health and safety



Carbon Monoxide alarms should be installed according to local codes

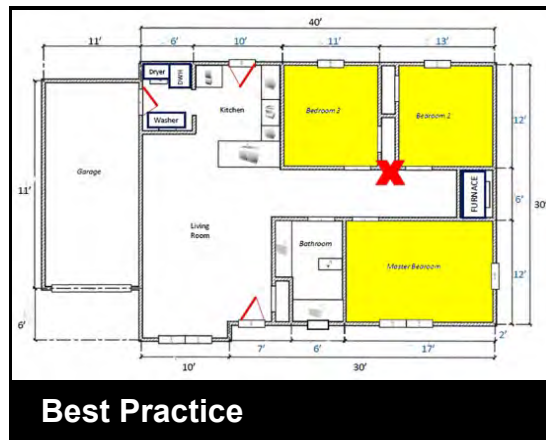

Alarms should be mounted near sleeping areas--such as the one marked in red

Tools:

- 1. Drill/screwdriver

Materials:

- 1. CO alarm
- 2. Fasteners

7.8102.3q

Desired Outcome:

Safe and reliable hot water source provided that meets occupant needs at lowest possible cost of ownership

Specification(s):

Completed work will be reviewed

Occupants will be educated on the safe and efficient operation and maintenance of the system, including:

- Adjustment of water temperature and target temperature in accordance with local code
- Operation of backflow preventer and pressure regulator (no occupant maintenance required)
- Importance of keeping operating manuals accessible

Objective(s):

Ensure occupant is informed of the safe, efficient operation and maintenance of the system

7.8103.1a

Desired Outcome:

Safe, reliable, and efficient operation of the appliance maintained

Specification(s):

Combustion safety testing will be performed in accordance with the Health and Safety Chapter of the Standard Work Specifications for Single-Family Housing or other equivalent practice

Electrical components will be verified to comply with NEC (e.g., no electrical box connector, no disconnect, improperly sized breaker and wire)

Objective(s):

Identify potential health and safety issues

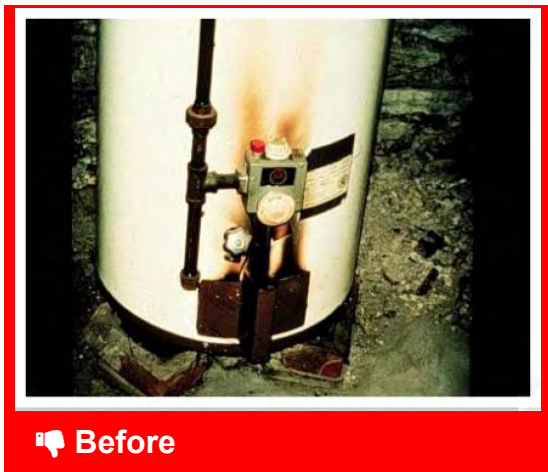

Complete combustion safety testing to ensure healthy, safe work environment



When completed work, retest to verify home is still healthy and safe

Tools:

1. Personal CO monitor
2. Combustion analyzer with probe
3. Manometer
4. Smoke pencil
5. Mirror
6. Stopwatch, timer, or watch with second hand

Materials:

1. CO alarm
2. Fasteners

See also SWS 2.0201.2a-2.0299.1i for all Combustion Safety details and SWS 2.0602.2c for Electrical Safety.

7.8103.1b

Desired Outcome:

Safe, reliable, and efficient operation of the appliance maintained

Specification(s):

Inspection will be conducted to show compliance with the 2012 IRC, including but not limited to:

- Water or fuel leaks
- Damaged wiring
- Venting issues with draft and condensation (e.g., soot, rusting of flue pipe, burned paint or wires, efflorescence)
- Corrosion (e.g., rust, mineral deposits)
- General condition of components

Objective(s):

Determine needed repairs or maintenance



In Progress

Inspect for rust, corrosion, and dust around draft diverter. Verify diverter is centered and fastened. Check T&P valve



In Progress

Inspect for signs of flame rollout, thermostat and gas valve condition, and proper T&P relief valve termination

Tools:

1. Flashlight
2. Inspection mirror

7.8103.1b - Visual inspection



Check draft diverter alignment



Inspect for rust, corrosion, and leaks

7.8103.1c

Desired Outcome:

Safe, reliable, and efficient operation of the appliance maintained

Specification(s):

Water heater storage tanks shall have a minimum R-value of R-24

Added insulation will not obstruct the unit's draft diverter, pressure relief valve, thermostats, hi-limit switch, plumbing pipes or elements, and thermostat access plates

The first 6' of inlet and outlet piping will be insulated in accordance with 2012 IRC N1103.4.2 or local requirements, whichever is greater

Objective(s):

Reduce standby losses from near tank piping and storage tank

Ensure insulation does not make contact with flue gas venting



Standard water heaters have built-in insulation ranging from R-7 to R-20.

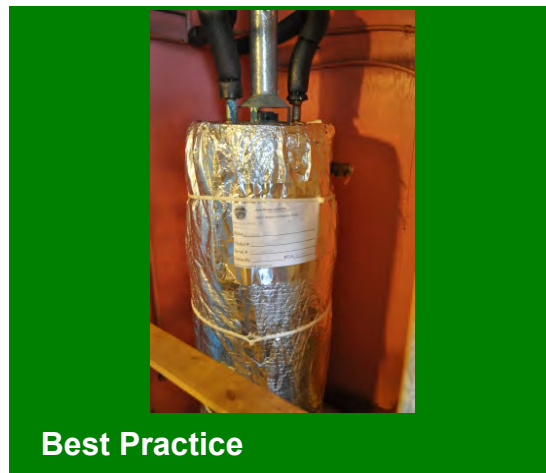

Best Practice

Storage-type water heaters should be wrapped to bring total value to R-24

Tools:

1. Scissors
2. Utility knife
3. Outward clinching staple gun

Materials:

1. Insulation blanket
2. Plastic zip ties
3. Tape
4. Staples

Determine the R-value of the existing water heater by A) searching the internet using the model number or B) measuring the thickness of the existing insulation and multiplying by 3.14 per inch for fiberglass or 6.25 per inch for foam. Add insulating wrap to achieve at least R-24. R-values may be

added, so a tank with a factory-installed R-value of R-6 would need an additional R-18 to reach the desired value of R-24.

Maintain 2" clearance between insulation and the draft diverter. Cut out around thermostats, pressure relief valves, and other items listed in the specification.

7.8103.1c - Thermal efficiency



Check occupant's water heater model to see what r-value is built-in

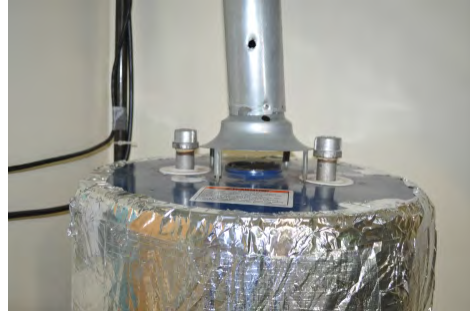

Blanket does not obstruct draft diverter or plumbing pipes and elements



Wrap does not obstruct ventilation, thermostat access plate, hi-limit switch, or fuel line



Data plate should still be accessible after wrapping

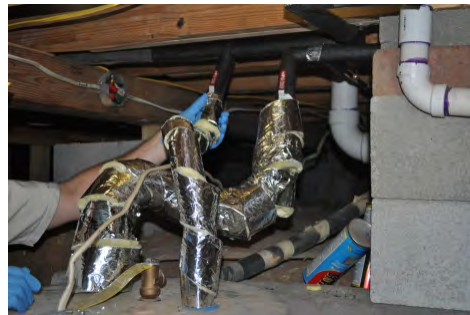

Both hot and cold water pipes should be insulated to R-3 for first 6ft

7.8103.1d

Desired Outcome:

Safe, reliable, and efficient operation of the appliance maintained

Specification(s):

A potable water expansion tank will be installed on the cold water side

Tanks that leak or have excessive corrosion will be replaced

A direct connection with no valves from the expansion tank to the storage tank will be installed

Connection will be properly supported with strapping

An expansion tank drain will be included in nonbladder tanks

Tank will be installed to accepted industry standards, in accordance with the 2012 IRC and according to manufacturer specifications

Tanks that are completely full of water will be drained and refilled before being replaced or repaired

Expansion tanks with bladders will have air charged to the manufacturer pressure requirements while water is not present in the tank

Bladder tanks with water inside of the air bladder will be replaced in accordance with manufacturer specifications

All work shall be completed by a licensed plumbing professional where required by the authority having jurisdiction and installed to industry-accepted standards

Objective(s):

Absorb water expansion of the system



👍 After

Potable water expansion tank

7.8103.1e

Desired Outcome:

Safe, reliable, and efficient operation of the appliance maintained

Specification(s):

Correct temperature and pressure relief valve will be installed in compliance with P2803 of the 2012 IRC and according to manufacturer specifications

Temperature and pressure relief valve discharge tube will be installed in accordance with P2803.6.1 of the 2012 IRC

Objective(s):

Discharge excessive energy (pressure or temperature) from storage tank to safe location



Water heaters should be not capped of at t&p valve

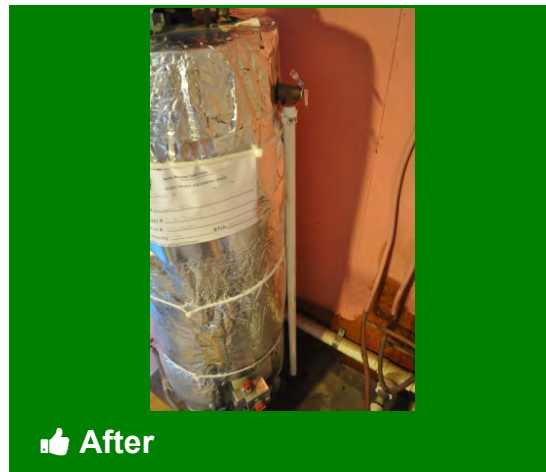

T&P discharge should be piped to a safe and observable location

Tools:

1. Pipe wrench
2. Hacksaw

Materials:

1. PVC
2. Plumber's epoxy

Check local jurisdictional codes. Paraphrased from 2012 IRC P2803.6.1: Temperature and pressure relief valve discharge pipes should not be connected to drainage system. T&P discharge pipes should be a clean line without valve or tee, flowing with gravity to an observable and safe location that cannot cause personal injury or structural damage -- the floor, an existing drain pan, a waste receptor, or to the outdoors. Pipe should not terminate more than 6" from floor, pan or waste receptor.

7.8103.1e - Temperature and pressure relief valve



GOOD: T&P discharge should be piped within 6" of the floor or to outdoors



BAD: T&P discharge should flow with gravity and be observable



BAD: T&P discharge should not be piped into drainage system

7.8103.1f

Desired Outcome:

Safe, reliable, and efficient operation of the appliance maintained

Specification(s):

Occupants will be advised to keep records of all maintenance done to their system

Copies of or access to installation and operation manuals will be provided

Objective(s):

Provide a history of system installation and maintenance to improve chance of successful future maintenance or repair

7.8103.1g

Desired Outcome:

Safe, reliable, and efficient operation of the appliance maintained

Specification(s):

Carbon monoxide alarms will be installed in each dwelling in accordance with ASHRAE 62.2 and authority having local jurisdiction

Occupant will be provided information regarding the health effects and risk of high CO concentrations, as well as a list of monitors that can provide more detail regarding CO levels

Objective(s):

Ensure occupant life safety

Inform occupant regarding possible CO hazards

7.8103.1h

Desired Outcome:

Safe, reliable, and efficient operation of the appliance maintained

Specification(s):

Completed work will be reviewed

Occupants will be educated on the safe and efficient operation and maintenance of the system, including:

- Adjustment of water temperature and target temperature in accordance with local code
- Periodic drain and flush
- Periodic inspection, maintenance, or replacement of anode rod

Objective(s):

Ensure occupant is informed of the safe, efficient operation and maintenance of the system

7.8103.2a

Desired Outcome:

Safe, reliable, and efficient operation of the appliance maintained

Specification(s):

Combustion safety testing will be performed in accordance with the Health and Safety Chapter of the Standard Work Specifications for Single-Family Housing or other equivalent practice

Electrical components will be verified to comply with NFPA 70 National Electric Code (e.g., no electrical box connector, no disconnect, improperly sized breaker and wire)

Objective(s):

Identify potential health and safety issues



Safe

On-demand water heater



Best Practice

Check carbon monoxide levels in the appliance vent

Tools:

1. Personal CO monitor
2. Combustion analyzer with probe
3. Manometer
4. Smoke pencil

Materials:

1. CO alarm
2. Fasteners

See also SWS 2.0201.2a-2.0299.1i for all Combustion Safety details and SWS 2.0602.2c for Electrical Safety.

7.8103.2b

Desired Outcome:

Safe, reliable, and efficient operation of the appliance maintained

Specification(s):

Inspection will be conducted to show compliance with the 2012 IRC, including but not limited to:

- Water or fuel leaks
- Damaged or missing pipe insulation and tank insulation, where applicable
- Damaged wiring
- Venting issues with draft and condensation (e.g., soot, rusting of flue pipe, burned paint or wires, efflorescence)
- Corrosion (e.g., rust, mineral deposits)
- General condition of components

Objective(s):

Determine needed repairs or maintenance



Check installation and ensure it meets manufacturer's instructions and local codes

7.8103.2b - Visual inspection



1
Inspect for rust, corrosion, and dust around draft diverter. Verify diverter is centered and fastened. Check T&P valve



2
Check draft diverter alignment



3
Inspect for rust, corrosion, and leaks



4
Inspect for signs of flame rollout, thermostat and gas valve condition, and proper T&P relief valve termination

7.8103.2c

Desired Outcome:

Safe, reliable, and efficient operation of the appliance maintained

Specification(s):

Correct temperature and pressure relief valve will be installed in compliance with P2803 of the 2012 IRC and according to manufacturer specifications

Temperature and pressure relief valve discharge tube will be installed in accordance with P2803.6.1 of the 2012 IRC

Objective(s):

Discharge excessive energy (pressure or temperature) from storage tank to safe location



Unsafe

Water heaters should be not capped off at T&P relief valve



Safe

T&P discharge should be piped to a safe and observable location

Tools:

1. Pipe wrench
2. Hacksaw or tubing cutter
3. Propane or MAPP gas torch

Materials:

1. CPVC or copper piping and fittings
2. CPVC primer and cement
3. Flux, solder, and emery cloth for sweating copper fittings
4. Teflon tape or pipe thread sealing compound

Check local jurisdictional codes. Paraphrased from 2012 IRC P2803.6.1: Temperature and pressure relief valve discharge pipes should not be connected to drainage system. T&P discharge pipes should be a clean line without valve or tee, flowing with gravity to an observable and safe location that cannot cause personal injury or structural damage -- the floor, an existing drain pan, a waste receptor, or to the outdoors. Pipe should not terminate more than 6" from floor, pan or waste receptor.

7.8103.2c - Temperature and pressure relief valve



GOOD: T&P discharge should be piped within 6" of the floor or to outdoors



BAD: T&P discharge should flow with gravity and be observable



BAD: T&P discharge should not be piped into drainage system

7.8103.2d

Desired Outcome:

Safe, reliable, and efficient operation of the appliance maintained

Specification(s):

Undiluted flue gases will be checked with a calibrated combustion analyzer in accordance with BPI-1100-T-2012

If combustion is not in compliance with BPI-1100-T-2012, diagnostics and adjustments will be done to manufacturer specifications or local codes

Objective(s):

Perform combustion testing

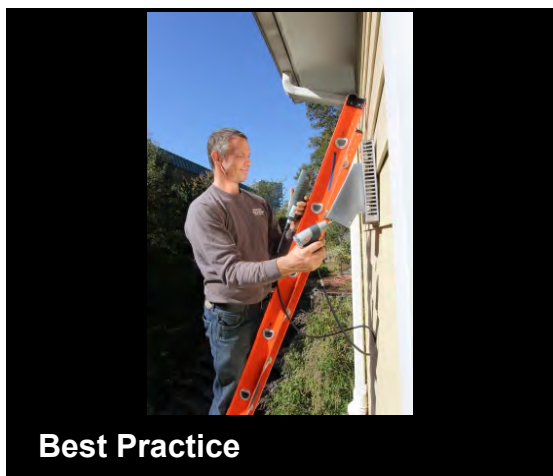

Test flue gases at outlet of vent to verify carbon monoxide levels are within specifications

Tools:

1. Properly calibrated combustion analyzer

7.8103.2d - Flue gas testing



Verify that calibration date is current on combustion analyzer



Test flue gases for carbon monoxide at outlet of vent



Verify that carbon monoxide levels are within specifications

7.8103.2e

Desired Outcome:

Safe, reliable, and efficient operation of the appliance maintained

Specification(s):

If sealed combustion has not been installed:

- Combustion and ventilation (excess air) requirements of gas-fired appliances, including provision of outside and inside air to account for building tightness, will be provided
- The minimum required volume will be 50 cubic feet per 1,000 Btu/h in accordance with 2012 IRC G2407.5.1
- If needed, additional combustion air will be provided in accordance with 2012 IRC G2407

Objective(s):

Ensure adequate combustion air for operation of the appliance



Calculate available combustion air for natural draft appliances



See Notes and images on next page for required combustion air

Tools:

1. Calculator
2. Tape measure

To determine adequate combustion air: add up the input Btus of all combustion appliances in the space and divide by 20. The result is the minimum required air volume in cubic feet (50 cubic feet per 1,000 input Btus). If the available volume is less than 50 cubic feet per 1,000 input Btus, provide additional combustion air as listed below for each circumstance, in accordance with the 2012 IRC G2407.

Image 1: For homes with one permanent opening, see 2012 IRC: G2407.6.2 (304.6.2): a minimum free area of 1 in² per 3,000 Btu/h (734 mm²/kW) of total input rating of all appliances

Image 2: For homes with two permanent vertical duct openings, see 2012 IRC G2407.6.1 (304.6.1): a minimum free area of 1 in² per 4,000 Btu/h (550 mm²/kW) of total input rating of all appliances

Image 3: For homes with two permanent horizontal duct openings, see 2012 IRC G2407.6.1 (304.6.1): a minimum free area of 1 in² per 2,000 Btu/h (1,100 mm²/kW) of total input rating of all appliances

7.8103.2e - Required combustion air

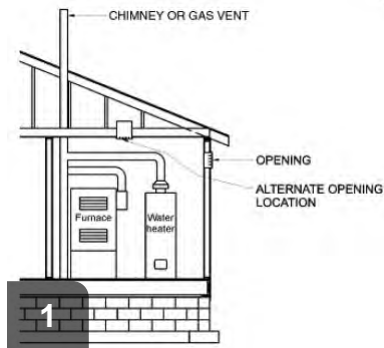

min free area of 1 sqin per 3,000 Btu/h (734 mm²/kW) of total input rating

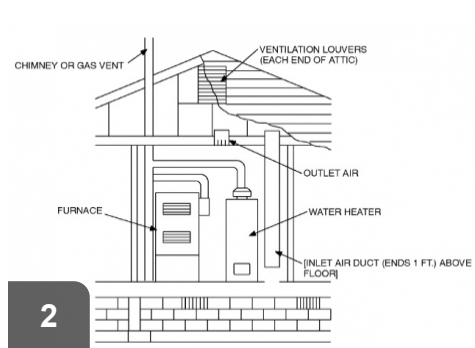

min free area of 1 sqin per 4,000 Btu/h (550 mm²/kW) of total input rating

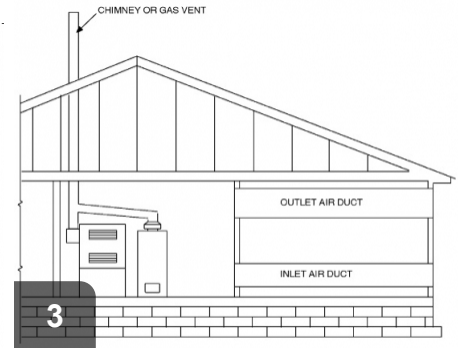

min free area of 1 sqin per 2,000 Btu/h (1100 mm²/kW) of total input rating

7.8103.2f

Desired Outcome:

Safe, reliable, and efficient operation of the appliance maintained

Specification(s):

Condition of venting will be inspected in accordance with Section 504 IFGC, NFPA 54, or NFPA 58 for gas water heaters or NFPA 31 for oil water heaters, and authority having local jurisdiction

Objective(s):

Verify proper venting of flue gases



Inspect direct vents for proper connections, rust, corrosion, and clearances



Inspect direct venting for proper connections, rust, corrosion, and clearances

Tools:

1. Flashlight
2. Inspection mirror

Check that all connections are secure, free of rust and corrosion, and that vents are made from the proper material. Verify that sealed combustion units are installed as direct vents, that is, with both combustion air intakes and exhaust gas vents connected.

Check that terminal locations are in accordance with the IRC, Section G2407, manufacturer's instructions, and/or local codes.

7.8103.2f - Venting of flue gases

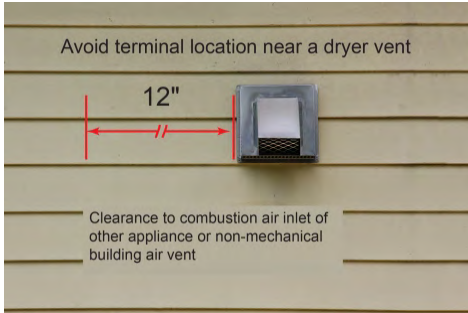

Verify 12" between a vent terminal and any non-mechanical building vent or combustion air inlet from another appliance

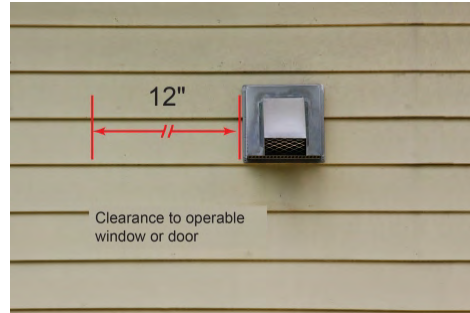

Check that there is 12" between vent terminals and any operable door or window

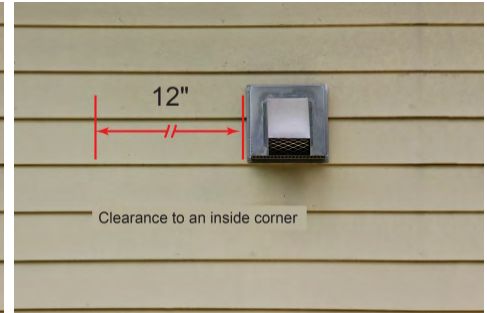

Ensure 12" clearance from the edge of a vent to any inside corner of the building

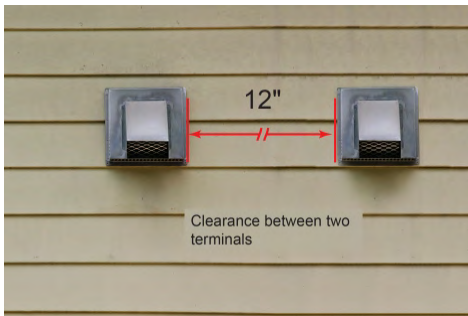

Verify 12" between any two vent terminals

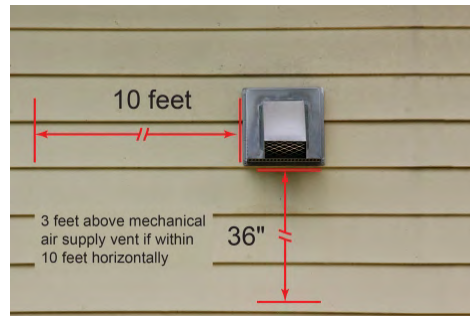

Verify vent terminals are least 3 feet higher than any mechanical air inlet closer than 10 feet away horizontally

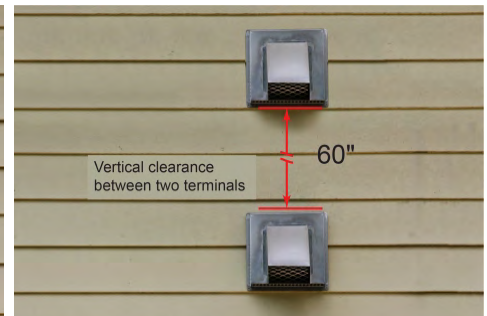

Ensure there is 60" between terminals in line vertically



Verify vent terminals are 36" below any eave, soffit, porch, or deck within 24 horizontal inches of center of vent



Ensure that vents are at least 36" above grade, porch, deck, veranda, or snow line

7.8103.2g

Desired Outcome:

Safe, reliable, and efficient operation of the appliance maintained

Specification(s):

Condition of fuel supply components will be checked in accordance with NFPA 31 for oil, NFPA 54 for gas, NFPA 58 for propane, or NFPA 70 National Electric Code for electric, and authority having jurisdiction

Objective(s):

Verify sufficient fuel to the water heater burner and element

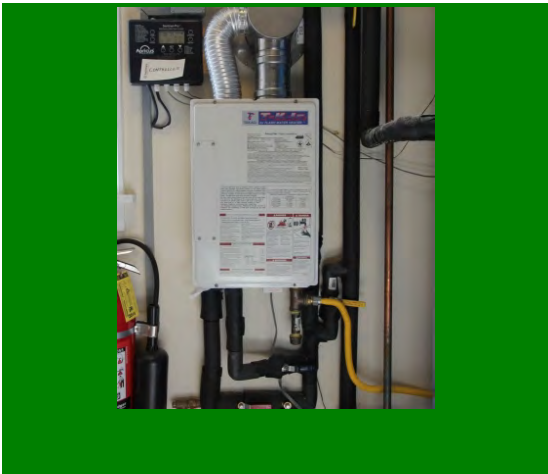

Inspect fuel supply and verify that sizing and capacity are correct

Tools:

1. Flashlight

7.8103.2g - Fuel supply



Inspect gas lines for corrosion, leaky fittings, worn flex lines, sediment traps and drip legs, and kinked copper



Inspect LP gas tanks for corrosion, proper location, leaky fittings, and kinked or damaged copper

7.8103.2h

Desired Outcome:

Safe, reliable, and efficient operation of the appliance maintained

Specification(s):

Water supplied to the appliance will be of sufficient volume and pressure to be in accordance with manufacturer specifications

Objective(s):

Verify sufficient volume and pressure of water to the appliance

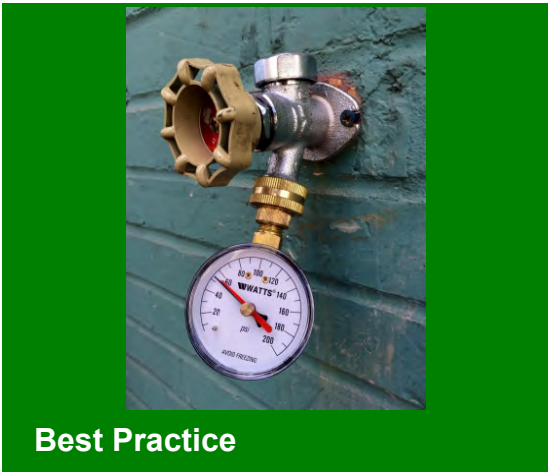

Testing water supply pressure

Tools:

1. Water pressure gauge

Check manufacturer's specifications for flow and pressure requirements. System pressure may be easily measured with a pressure gauge attached to a hose bib or faucet. Pipe sizing calculations (to ensure adequate flow rates) are best left to a licensed plumber or mechanical contractor.

7.8103.2i

Desired Outcome:

Safe, reliable, and efficient operation of the appliance maintained

Specification(s):

Discharge temperature will be set not to exceed 120°F or in accordance with local code, whichever is lower

Objective(s):

Ensure safe hot water supply temperature to fixtures



Unsafe

Water heaters producing water over 120 degrees raise heating costs



Safe

Water heaters should produce water under 120 degrees to prevent scalding

Tools:

1. Thermometer

7.8103.2i - Discharge temperature



1 Test temperature of hot water at faucets in house



2 Hot water temperatures should not exceed 120 degrees Fahrenheit



3 Adjust water heater settings and insulate as needed



4 After adjustment and insulation, retest to verify temp is under 120 degrees

7.8103.2j

Desired Outcome:

Safe, reliable, and efficient operation of the appliance maintained

Specification(s):

The following will be tested:

- Safety controls (e.g., water, air pressure switches)
- Combustion safety and efficiency
- Operational controls
- Fuel and water leaks
- Unit runs through complete cycle
- Local code requirements

Manufacturer specifications and all relevant industry standards will be met

Objective(s):

Ensure system functions safely with lowest possible cost of ownership

7.8103.2k

Desired Outcome:

Safe, reliable, and efficient operation of the appliance maintained

Specification(s):

Occupants will be advised to keep records of all maintenance done to their system

Copies of or access to installation and operation manuals will be provided

Objective(s):

Improve chance of successful future maintenance or repair

7.8103.2I

Desired Outcome:

Safe, reliable, and efficient operation of the appliance maintained

Specification(s):

All homes will have a carbon monoxide (CO) alarm

Objective(s):

Ensure occupant health and safety

7.8103.2m

Desired Outcome:

Safe, reliable, and efficient operation of the appliance maintained

Specification(s):

Completed work will be reviewed

Occupants will be educated on the safe and efficient operation and maintenance of the system, including:

- Adjustment of water temperature
- Target temperature in accordance with local code

Objective(s):

Ensure occupant is informed of the safe, efficient operation and maintenance of the system